

- V_{DS} 240 V
- I_D 0.25 A
- $R_{DS(on)}$ 8 Ω
- $V_{GS(th)}$ 0.6 ... 1.2 V
- N channel
- Enhancement mode
- Logic level

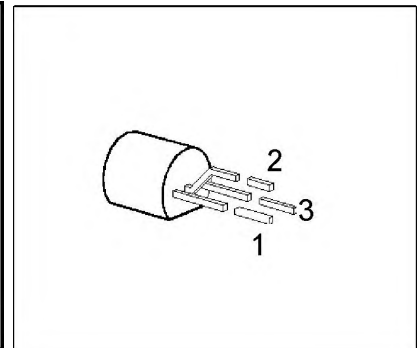
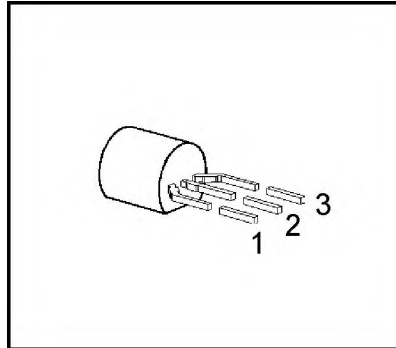

Type	Ordering Code	Tape and Reel Information	Pin Configuration			Marking	Package
			1	2	3		
BSS 88	Q62702-S454	bulk	G	D	S	BSS 88 marked SS88	TO-92
BSS 88	Q62702-S287	E6288: 1500 pcs/reel; 2 reels/carton; gate first					
BSS 88	Q62702-S303	E6296: 1500 pcs/reel; 2 reels/carton; source first					
BSS 88	Q62702-S576	E6325: 2000 pcs/carton; Ammopack					

Maximum Ratings

Parameter	Symbol	Values	Unit
Drain-source voltage	V_{DS}	240	V
Drain-gate voltage, $R_{GS} = 20 \text{ k}\Omega$	V_{DGR}	240	
Gate-source voltage	V_{GS}	± 14	
Gate-source peak voltage, aperiodic	V_{gs}	± 20	
Continuous drain current, $T_A = 25 \text{ }^\circ\text{C}$	I_D	0.25	A
Pulsed drain current, $T_A = 25 \text{ }^\circ\text{C}$	$I_{D \text{ puls}}$	1.0	
Max. power dissipation, $T_A = 25 \text{ }^\circ\text{C}$	P_{tot}	1.0	W
Operating and storage temperature range	T_j, T_{stg}	- 55 ... + 150	$^\circ\text{C}$
Thermal resistance, chip-ambient (without heat sink)	R_{thJA}	≤ 125	K/W
DIN humidity category, DIN 40 040	-	E	-
IEC climatic category, DIN IEC 68-1	-	55/150/56	-

Electrical Characteristics

at $T_j = 25\text{ °C}$, unless otherwise specified.

Parameter	Symbol	Values			Unit
		min.	typ.	max.	

Static Characteristics

Drain-source breakdown voltage $V_{GS} = 0, I_D = 0.25\text{ mA}$	$V_{(BR)DSS}$	240	–	–	V
Gate threshold voltage $V_{GS} = V_{DS}, I_D = 1\text{ mA}$	$V_{GS(th)}$	0.6	0.8	1.2	
Zero gate voltage drain current $V_{DS} = 240\text{ V}, V_{GS} = 0$ $T_j = 25\text{ °C}$ $T_j = 125\text{ °C}$	I_{DSS}	–	0.1	1.0	μA
		–	10	100	
$V_{DS} = 100\text{ V}, V_{GS} = 0$ $T_j = 25\text{ °C}$		–	–	100	nA
Gate-source leakage current $V_{GS} = 20\text{ V}, V_{DS} = 0$	I_{GSS}	–	10	100	nA
Drain-source on-resistance $V_{GS} = 4.5\text{ V}, I_D = 0.25\text{ A}$ $V_{GS} = 1.8\text{ V}, I_D = 14\text{ mA}$	$R_{DS(on)}$	–	4.0	8	Ω
		–	6	15	

Dynamic Characteristics

Forward transconductance $V_{DS} \geq 2 \times I_D \times R_{DS(on)max}, I_D = 0.25\text{ A}$	g_{fs}	0.14	0.32	–	S
Input capacitance $V_{GS} = 0, V_{DS} = 25\text{ V}, f = 1\text{ MHz}$	C_{iss}	–	100	135	pF
Output capacitance $V_{GS} = 0, V_{DS} = 25\text{ V}, f = 1\text{ MHz}$	C_{oss}	–	15	25	
Reverse transfer capacitance $V_{GS} = 0, V_{DS} = 25\text{ V}, f = 1\text{ MHz}$	C_{rss}	–	8	12	
Turn-on time t_{on} , ($t_{on} = t_{d(on)} + t_r$) $V_{DD} = 30\text{ V}, V_{GS} = 10\text{ V}, R_{GS} = 50\text{ }\Omega, I_D = 0.28\text{ A}$	$t_{d(on)}$	–	5	8	ns
	t_r	–	10	15	
Turn-off time t_{off} , ($t_{off} = t_{d(off)} + t_f$) $V_{DD} = 30\text{ V}, V_{GS} = 10\text{ V}, R_{GS} = 50\text{ }\Omega, I_D = 0.28\text{ A}$	$t_{d(off)}$	–	40	55	
	t_f	–	30	40	

Electrical Characteristics (cont'd)

at $T_j = 25\text{ °C}$, unless otherwise specified.

Parameter	Symbol	Values			Unit
		min.	typ.	max.	

Reverse Diode

Continuous reverse drain current $T_A = 25\text{ °C}$	I_S	—	—	0.25	A
Pulsed reverse drain current $T_A = 25\text{ °C}$	I_{SM}	—	—	1.0	
Diode forward on-voltage $I_F = 0.5\text{ A}, V_{GS} = 0$	V_{SD}	—	0.85	1.3	V

Package Outline

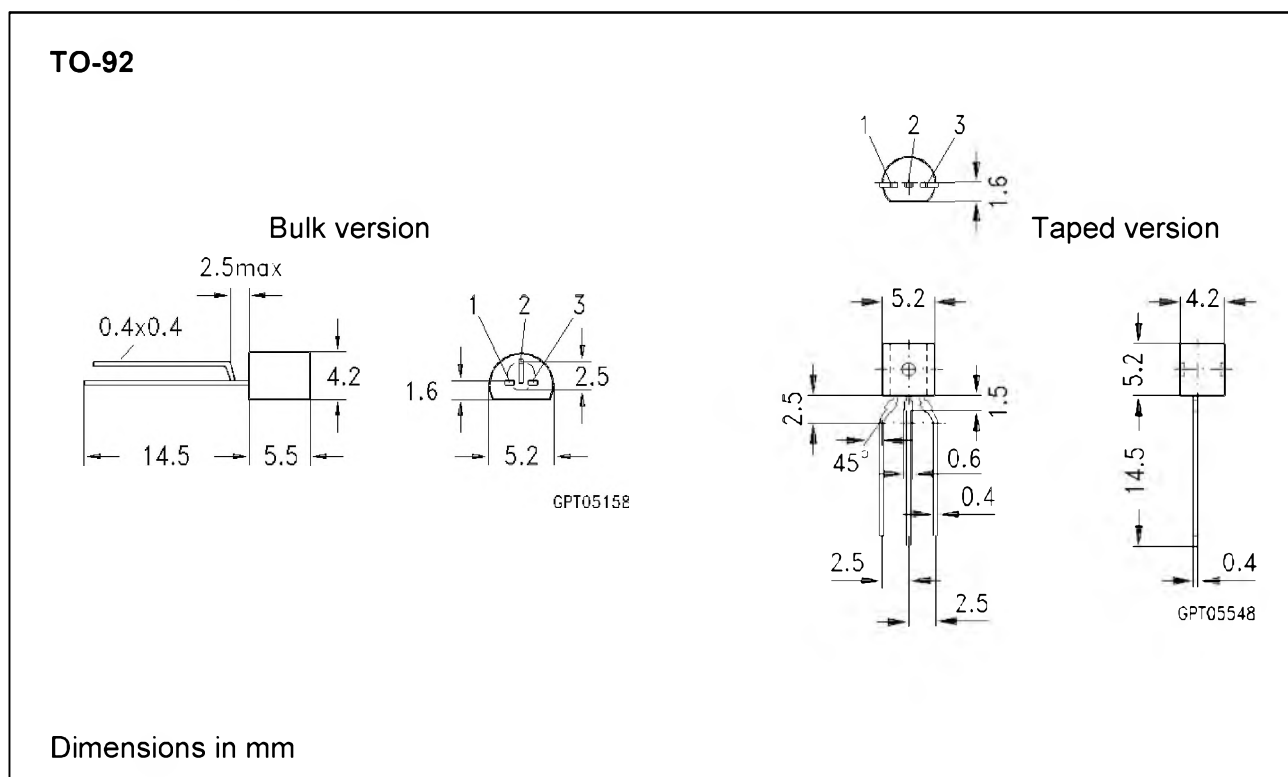

Characteristics

at $T_J = 25^\circ\text{C}$, unless otherwise specified.

Total power dissipation $P_{\text{tot}} = f(T_A)$

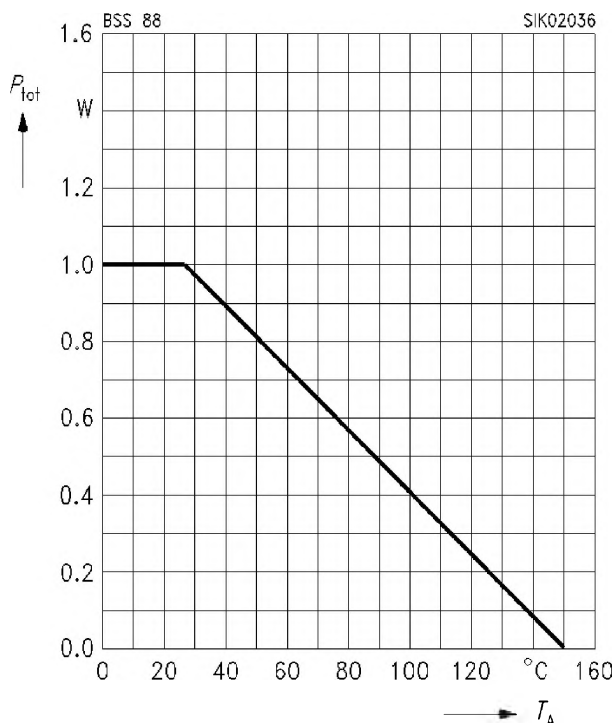

Safe operating area $I_D = f(V_{\text{DS}})$

parameter: $D = 0.01$, $T_C = 25^\circ\text{C}$

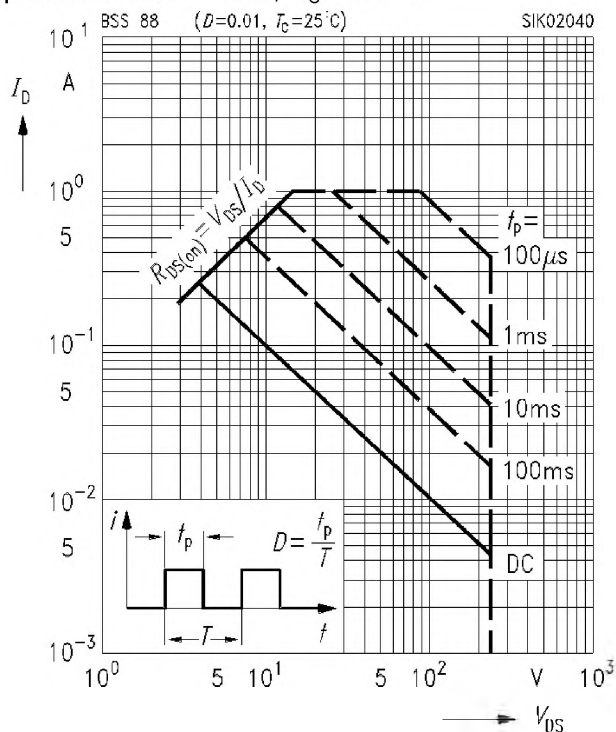

Typ. output characteristics $I_D = f(V_{\text{DS}})$

parameter: $t_p = 80\mu\text{s}$

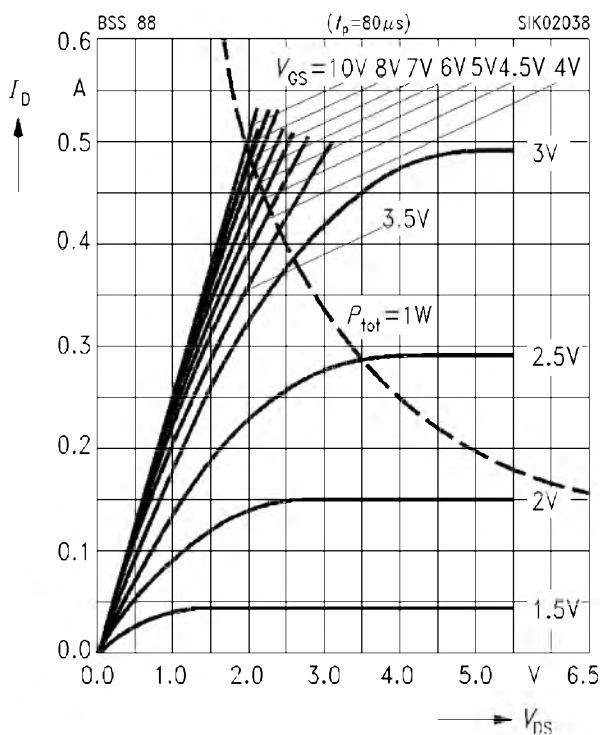

Typ. drain-source on-resistance

$R_{\text{DS(on)}} = f(I_D)$

parameter: V_{GS}

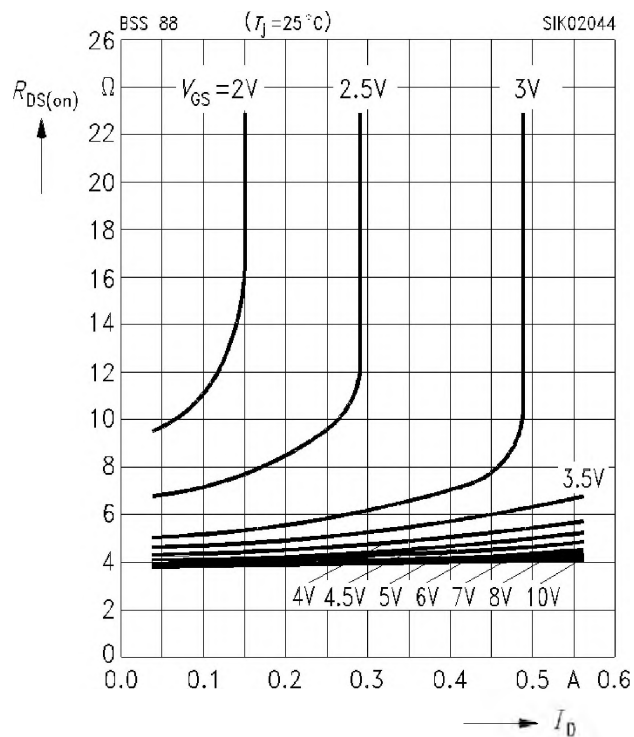

Typ. transfer characteristics $I_D = f(V_{GS})$

parameter: $t_p = 80 \mu s$, $V_{DS} \geq 2 \times I_D \times R_{DS(on)max.}$

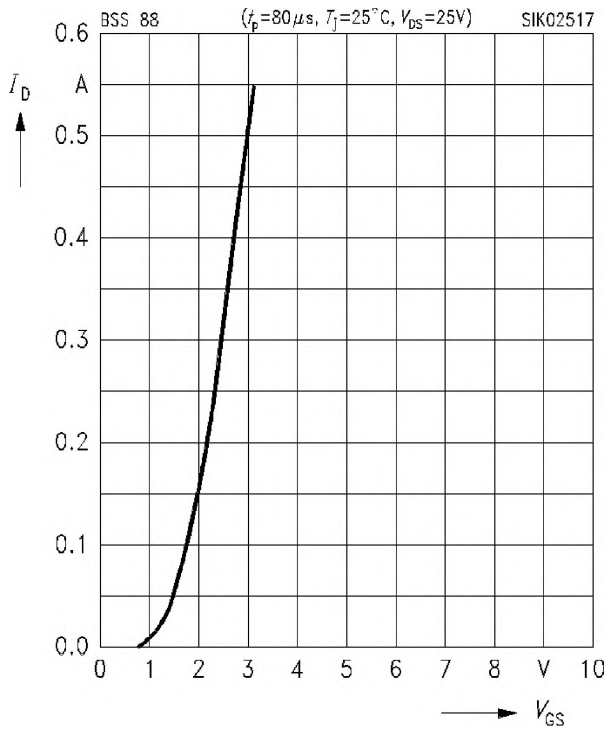

Typ. forward transconductance $g_{fs} = f(I_D)$

parameter: $V_{DS} \geq 2 \times I_D \times R_{DS(on)max.}$, $t_p = 80 \mu s$

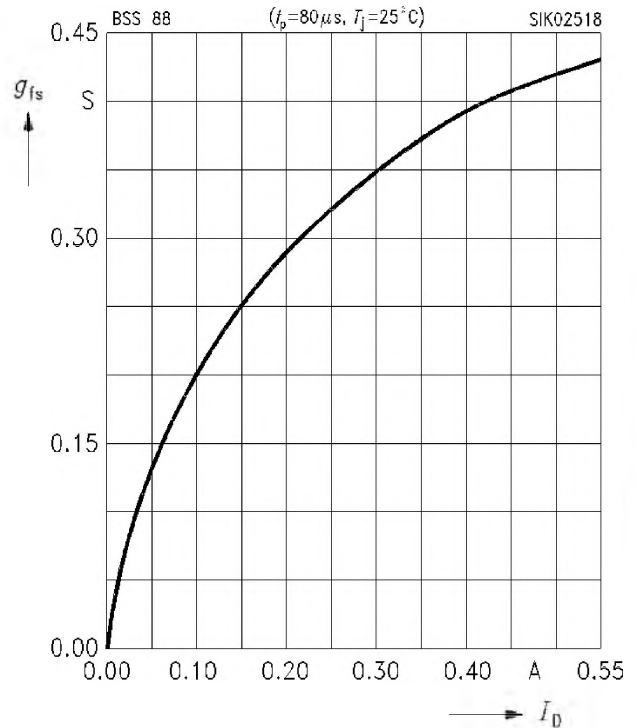

Drain-source on-resistance $R_{DS(on)} = f(T_j)$

parameter: $I_D = 0.25 A$, $V_{GS} = 4.5 V$, (spread)

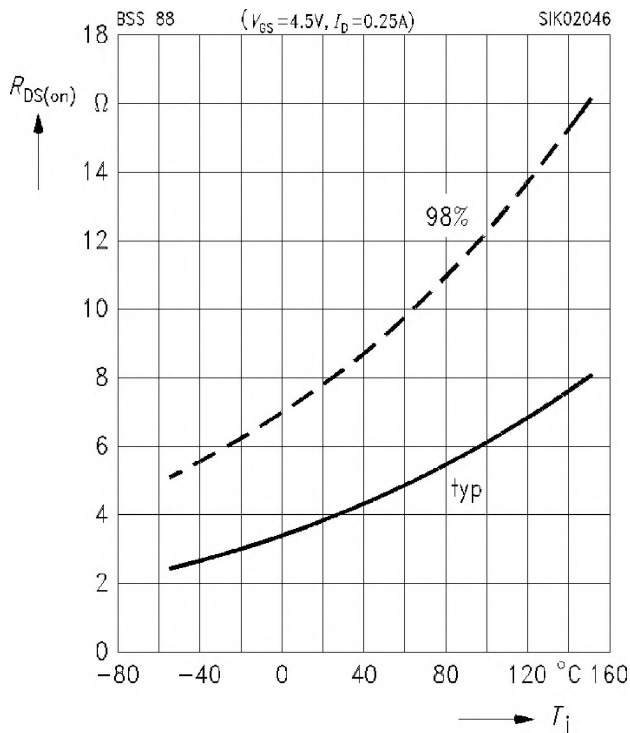

Typ. capacitances $C = f(V_{DS})$

parameter: $V_{GS} = 0$, $f = 1 MHz$

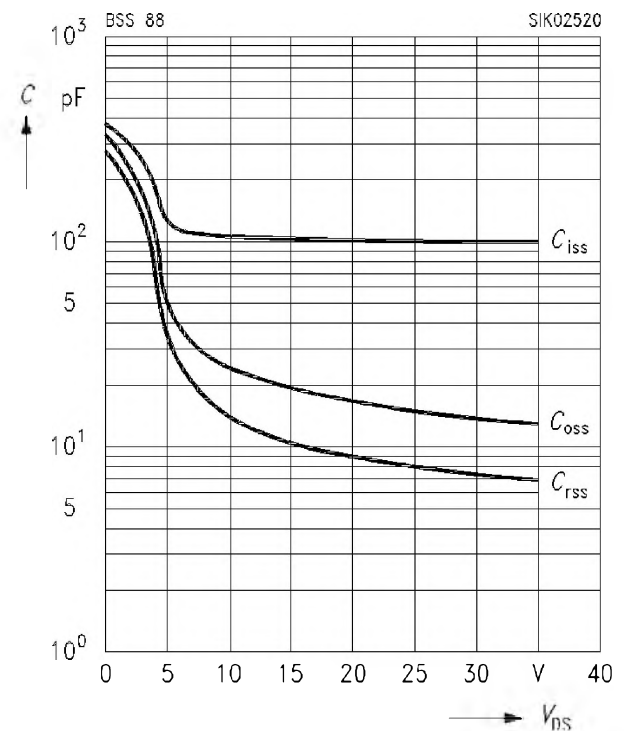

Gate threshold voltage $V_{GS(th)} = f(T_j)$
 parameter: $V_{DS} = V_{GS}$, $I_D = 1 \text{ mA}$, (spread)

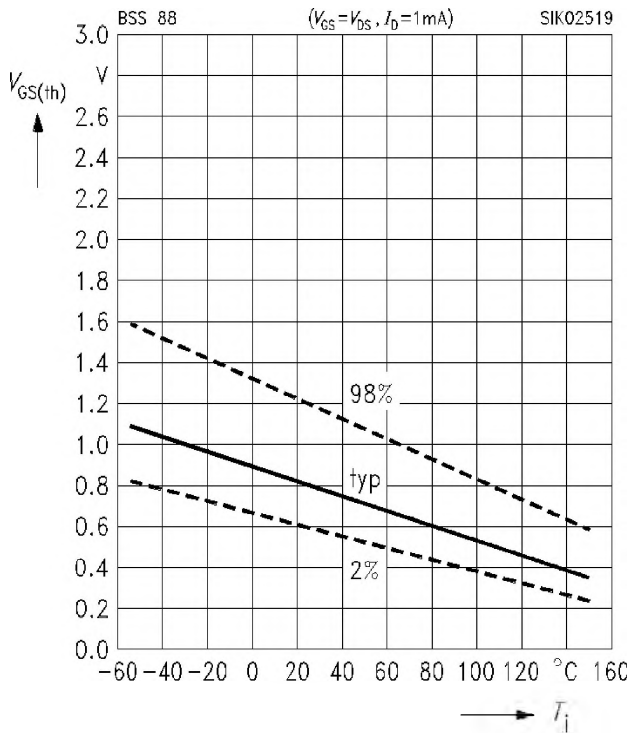

Forward characteristics of reverse diode
 $I_F = f(V_{SD})$
 parameter: $t_p = 80 \mu\text{s}$, T_j , (spread)

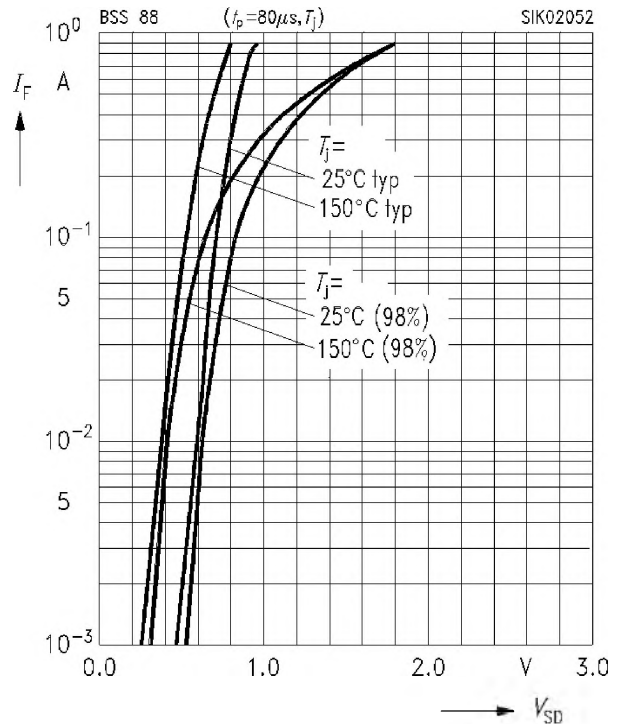

Drain current $I_D = f(T_A)$
 parameter: $V_{GS} \geq 5 \text{ V}$

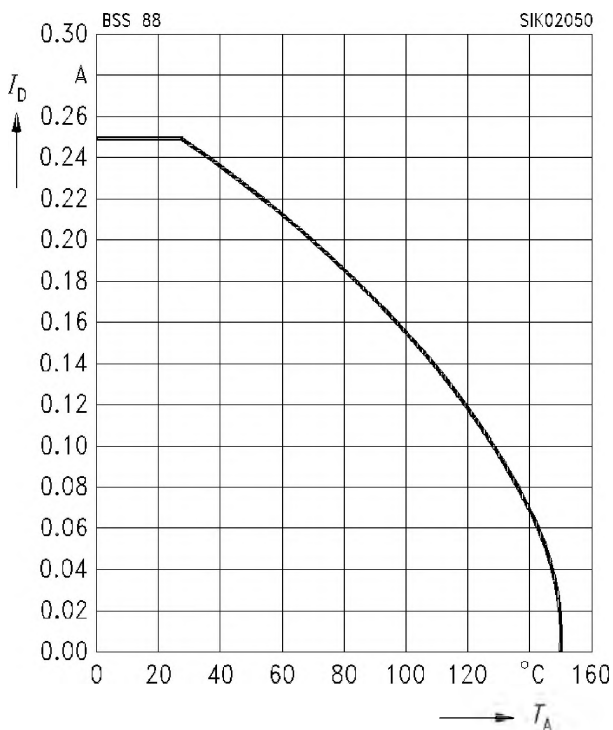

Drain-source breakdown voltage
 $V_{(BR)DSS} = b \times V_{(BR)DSS} (25 \text{ °C})$

