

HIGH-VOLTAGE AMPLIFIERS

DESCRIPTION

The BFX90 and BFX91 are silicon planar epitaxial PNP transistors in Jedec TO-18 (BFX90) and Jedec TO-39 (BFX91) metal cases.

Both devices feature high voltage, high gain, low noise and excellent current gain linearity from 10 μ A to 50 mA.

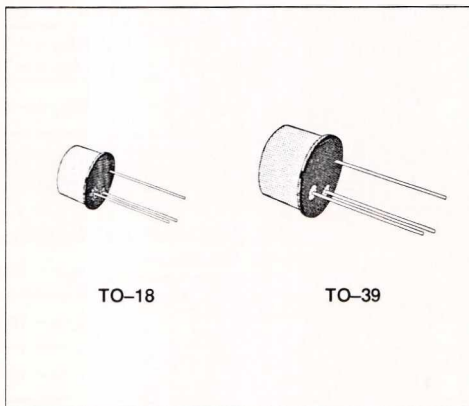

INTERNAL SCHEMATIC DIAGRAM

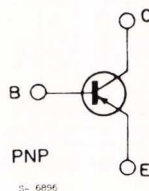

ABSOLUTE MAXIMUM RATINGS

Symbol	Parameter	Value	Unit
V_{CBO}	Collector-base Voltage ($I_E = 0$)	- 180	V
V_{CEO}	Collector-emitter Voltage ($I_B = 0$)	- 180	V
V_{EBO}	Emitter-base Voltage ($I_C = 0$)	- 6	V
I_C	Collector Current	- 100	mA
P_{tot}	Total Power Dissipation at $T_{amb} \leq 25^\circ\text{C}$		
	for BFX90	0.4	W
	for BFX91	0.7	W
	at $T_{case} \leq 25^\circ\text{C}$		
	for BFX90	1.4	W
	for BFX91	2.5	W
T_{stg}, T_j	Storage and Junction Temperature	- 55 to 200	$^\circ\text{C}$

THERMAL DATA

			BFX90	BFX91	Unit
$R_{th\ j-case}$	Thermal Resistance Junction-case	Max	125	70	$^{\circ}C/W$
$R_{th\ j-amb}$	Thermal Resistance Junction-ambient	Max	438	250	$^{\circ}C/W$

ELECTRICAL CHARACTERISTICS ($T_{amb} = 25\ ^{\circ}C$ unless otherwise specified)

Symbol	Parameter	Test Conditions	Min.	Typ.	Max.	Unit
I_{CBO}	Collector Cutoff Current ($I_E = 0$)	$V_{CB} = -100\ V$ $V_{CB} = -100\ V\ T_{amb} = 125\ ^{\circ}C$			-10 -10	nA μA
I_{EBO}	Emitter Cutoff Current ($I_C = 0$)	$V_{EB} = -4\ V$			-10	nA
$V_{(BR)\ CBO}$	Collector-base Breakdown Voltage ($I_E = 0$)	$I_C = -10\ \mu A$	-180			V
$V_{(BR)\ CEO}^*$	Collector-emitter Breakdown Voltage ($I_B = 0$)	$I_C = -2\ mA$	-180			V
$V_{(BR)\ EBO}$	Emitter-base Breakdown Voltage ($I_C = 0$)	$I_E = -10\ \mu A$	-6			V
$V_{CE\ (sat)}^*$	Collector-emitter Saturation Voltage	$I_C = -10\ mA\ I_B = -1\ mA$		-0.1	-0.25	V
$V_{BE\ (sat)}^*$	Base-emitter Saturation Voltage	$I_C = -10\ mA\ I_B = -1\ mA$		-0.74	-0.9	V
h_{FE}^*	DC Current Gain	$I_C = -10\ \mu A\ V_{CE} = -10\ V$ $I_C = -1\ mA\ V_{CE} = -10\ V$ $I_C = -10\ mA\ V_{CE} = -10\ V$ $I_C = -10\ \mu A\ V_{CE} = -10\ V$ $T_{amb} = -55\ ^{\circ}C$ $I_C = -100\ \mu A\ V_{CE} = -10\ V$ $T_{amb} = -55\ ^{\circ}C$	60 80 80 15 30	110 170 200 60 90	300	
h_{fe}	Small Signal Current Gain	$I_C = -1\ mA\ f = 1\ kHz\ V_{CE} = -10\ V$	80		400	
f_T	Transition Frequency	$I_C = -1\ mA\ f = 20\ MHz\ V_{CE} = -10\ V$	40	60	160	MHz
C_{EBO}	Emitter-base Capacitance	$I_C = 0\ f = 1\ MHz\ V_{EB} = -0.5\ V$		20	25	pF
C_{CBO}	Collector-base Capacitance	$I_E = 0\ f = 1\ MHz\ V_{CB} = -5\ V$		5	7	pF
NF	Noise Figure	$I_C = -10\ \mu A\ R_g = 10\ k\Omega$ $f = 10\ kHz\ B = 2\ kHz$ $f = 1\ kHz\ B = 200\ Hz$ $f = 100\ Hz\ B = 20\ Hz$		1 1 2	3 3 10	dB dB dB
h_{ie}	Input Impedance	$I_C = -1\ mA\ f = 1\ kHz\ V_{CE} = -10\ V$	2.5		12	k Ω
h_{oe}	Output Admittance	$I_C = -1\ mA\ f = 1\ kHz\ V_{CE} = -10\ V$	5		25	μS

* Pulsed : pulse duration = 300 μs , duty cycle = 1 %.

DC Current Gain.

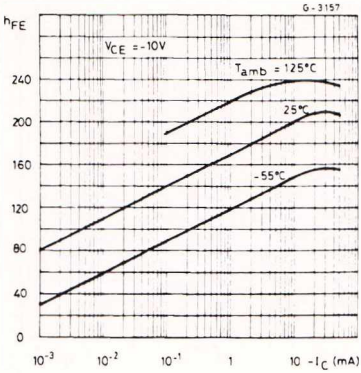

Collector-emitter Saturation Voltage.

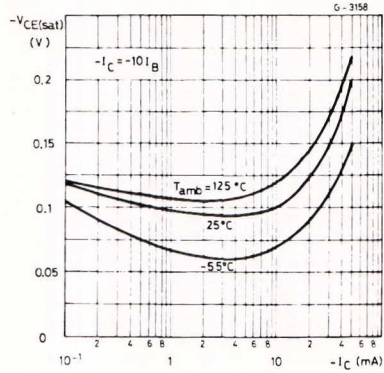

Base-emitter Saturation Voltage.

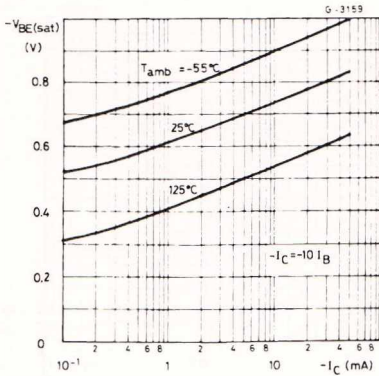

Normalized h Parameters vs. Collector Current.

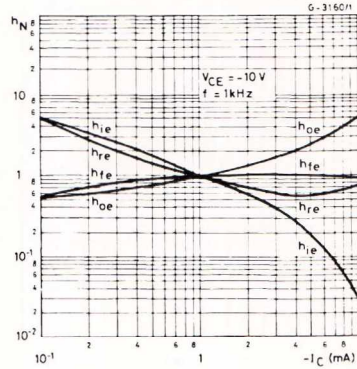

Normalized h Parameters vs. Ambient Temperature.

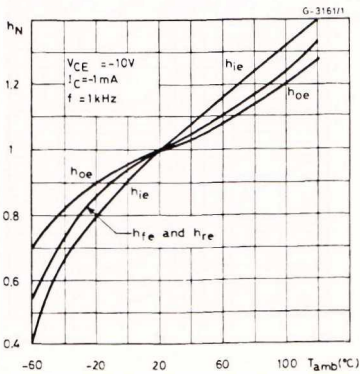

Emitter-base and Collector-base Capacitances.

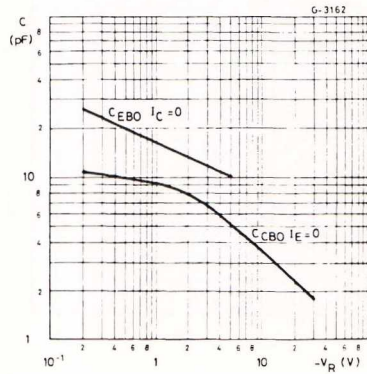

Contours of Constant Transition Frequency.

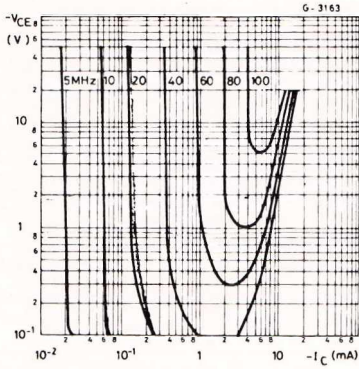

Equivalent Input Noise Voltage.

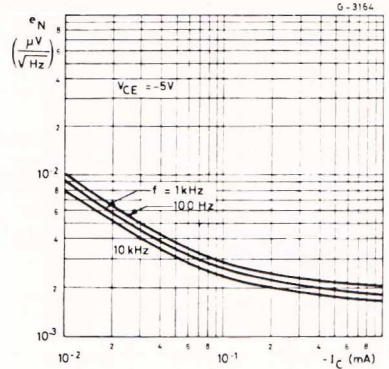

Equivalent Input Noise Current.

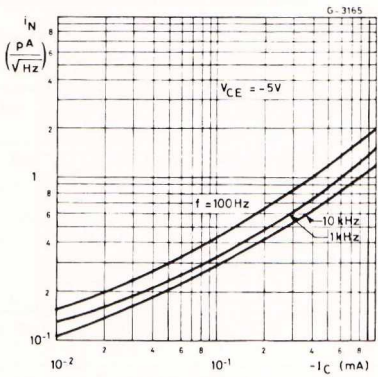

Contours of Constant Noise Figure (f = 100 Hz).

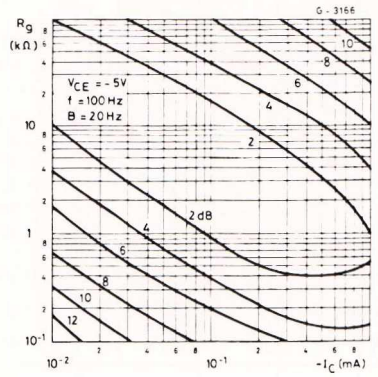

Contours of Constant Noise Figure (f = 1 kHz).

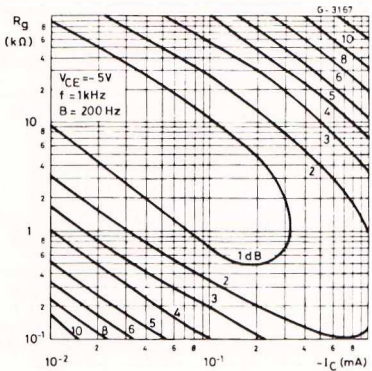

Contours of Constant Noise Figure (f = 10 kHz).

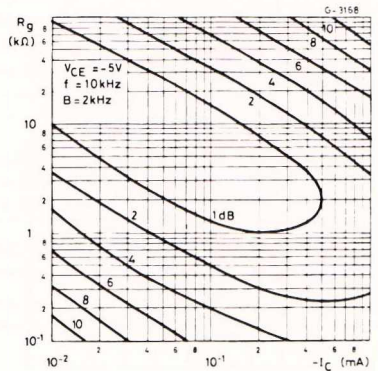

Contours of Constant Wide Band Noise Figure.

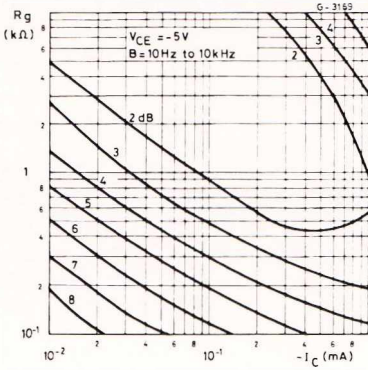

Noise Figure vs. Frequency.

