

CITIZENS BAND TRANSCEIVER
OPERATION AND MAINTENANCE



MODEL MARKO 5

OPERATION AND MAINTENANCE MANUAL

GENERAL INSTRUCTION

This unit is a combination transmitter and receiver designed for use in Class "D" operation in the 27MHz Citizens Radio Service. It is designed to meet the Federal Communication Commission requirements applicable to equipment in this service under Class "D" emission, and is not to be used for another purpose. You are required to read and understand rules part 95 of the F.C.C. regulations prior to operation of this unit.

Copies of manual VI (covering the F.C.C. regulation for the Citizens Band Radio Service) include Part 95 and are available from the superintendent of documents, U.S. Government Printing Office, Washington D.C. A station license must be obtained by submitting a properly completed Station License Application, Form 505, as directed. It is illegal to operate the transmitter section of this transceiver prior to receiving a valid station license and call sign.

GENERAL DESCRIPTION

This unit is a transceiver employing a frequency synthesizer circuit to provide 23 crystal-controlled transmit and receive channels in the 27 MHz Citizens band. This unit is an all solid stated unit making use of IC, FET, transistor and diode, and is a compact and high capacity transceiver. This unit can be operated over all 23 channels in the conventional AM mode (DSB), or in suppressed carrier Single Sideband (SSB) using either the upper or lower sideband, as desired, and is operated from 23 to 46 effective number of operating channels.

The transceiver has been carefully designed for ease of operation in the SSB mode. Selection of AM, upper sideband or lower sideband is achieved by a mode switch. For transmit on SSB only small consumption of RF power output is required since power output is consumed only on talking. Your SSB signal will reach farther and be heard more clearly than on AM signal. This unit includes every necessary feature for optimum communications — variable squelch, noise blanker, noise limiter (only AM), RF attenuator, fine tune, public address and P-S meter. It is designed for mobile operation such as auto mobiles or ships, and its standard power supply is DC 12V.

SPECIFICATIONS

General specifications:

- * Frequency range 26.965 / 27.255 MHz.
- * Modulation mode Conventional AM and suppressed carrier SSB
- * Channel composition Cristal synthesizer type
- * Frequency stability
 - * At room temperature (Within 50 Hz. deviation from assigned frequency)
 - * Temperature varies from -20°C to $+50^{\circ}\text{C}$. (Within 500 Hz. deviation from assigned frequency)
- * Polarity of power supply Negative ground DC 13.8V.

1. Transmitter specifications:

- * RF output on SSB mode 15 Watts input.
8 Watts PEP (Max. rate)
3 Watts (average carrier power)
Filter method. (SSB)
- * RF output on AM mode 3rd order distortion is more than 20dB below the either signal of 2 tone on SSB mode.
- * Modulation method All spurious and harmonics are more than 50dB below the carrier on both SSB and AM mode.
- * Modulation limiting (In case of SSB mode, this measurement will be made with authorized standard test procedure)
- * Spurious radiation Hum and noise on RF signal are more than 40dB below the signal.
- * Hum and noise Adjustable for 50 or 75 ohm antenna.
- * Antenna impedance More than 40dB below the either signal of two tone on SSB.
- * Carrier suppression

2. Receiver specifications:

- * Reception method on SSB Single conversion super heterodyne.
- * Reception method on AM Double conversion super heterodyne.
- * Intermediate frequency 7.8 MHz. (2nd 455 KHz. on AM mode).
- * Selectivity on SSB ± 1.2 KHz. at 6 dB, ± 2.3 KHz. at 50dB
- * Selectivity on AM ± 3 KHz. at 6dB, ± 10 KHz. at 50dB.
- * Spurious response More than 50dB spurious signal requires to produce same amount of audio output as desired signal does.
- * Audio output 2 Watts at 10% distortion.
- * Current drain approx. 250mA when no audio.

OPERATING CONTROLS AND FEATURES

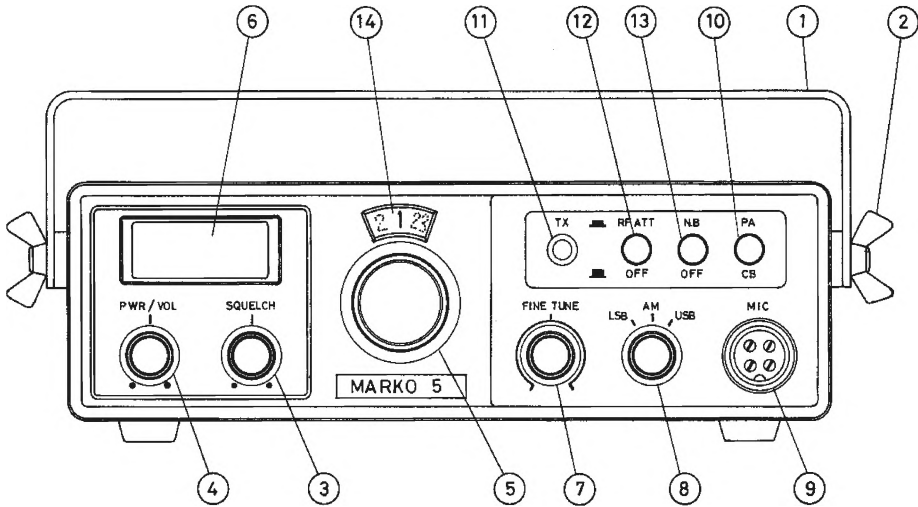

1. Mounting bracket:

Specially designed bracket simplifies mobile installation — has "quick-release" feature for fast removal of transceiver.

2. Wing NUT:

To attach bracket and unit.

3. Squelch:

This control is used to "quiet" the receiver during no-signal conditions. To adjust squelch threshold level at 12 o'clock (or similar location). Full clockwise provides maximum.

4. PWR/VOL:

Varies the audio volume from the speaker. Full clockwise provides Maximum. Incorporates an on-off power switch at the extreme counter clockwise position.

5. Channel Selector:

Dial shows 1-23 channels. The selected channel appears at channel indicator window (14), and also selects "black" mode (between channels 22 and 23).

6. S/RF power meter:

This meter is automatically switched to indicate incoming signal strength in the receive mode, and relative RF power output in the transmit mode. "S" scale to be adjusted at "S9" on input 100 μ V.

7. Fine tune:

Permits slight adjustment of receiver tuning used for clarity on SSB reception and fine tuning of stations on AM reception.

8. **Mode switch:**
Selects mode of operation among lower sideband, upper sideband and standard AM.
9. **Microphone socket:**
Four-pin socket for push-to-talk dynamic microphone with curl cord and dependable screw-on connector.
10. **CB PA SWITCH**
PA operation to be on when it is pushed.
11. **Transmit indicator:**
To indicate transmit using visible light emitting diode.
12. **RF ATT**
To push a push button switch on to reduce RF gain of receiver on strong signals.
13. **Noise Blanker;**
To push a push button switch on to control noise blanker. Which is very effective against ignition noise.
14. **Channel indicator window:**
To indicate transceive channel.
15. **Antenna connector:**
For antenna lead-in cable with matching PL-259 connector.
16. **TVI Trap:**
This is an adjustable network inserted into antenna. Factory adjusted should be adjusted by qualified technician only.

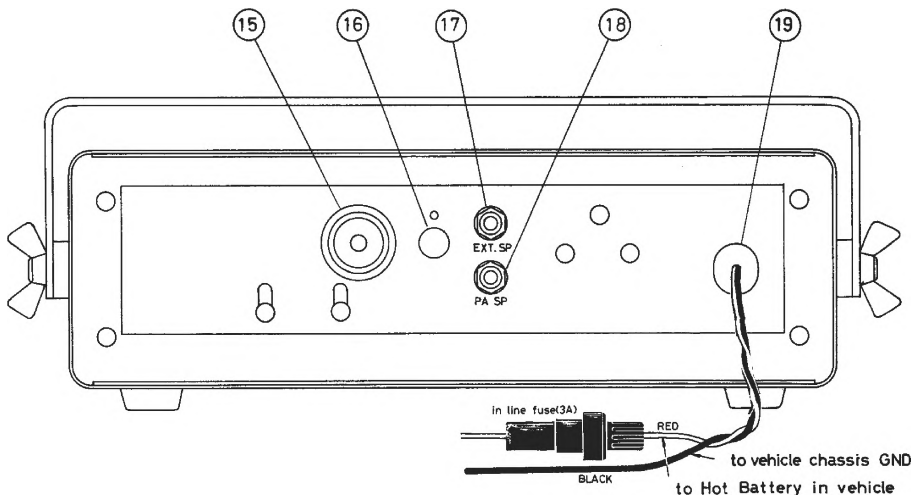

17. EXT SP:

Jack for connection of external devices such as headphone or speaker.

Insertion of a headphone plug into this jack will automatically disconnect the internal speaker

18. PA SP:

Special speaker jack for PA. Be sure to use PA speaker only on PA operation since internal speaker is disconnected. Use external speaker having 8~16 ohms impedance only.

19. Power line:

Power supply available for DC operation only. Red cord is hot (plus) and black cord cold (minus)

OPERATING INSTRUCTIONS

Never attempt to transmit without an antenna connected to the transceiver. Make sure the transceiver is properly installed for mobile operation and that the antenna and power source are connected. If you have not already done so, plug in the microphone.

Receive Mode AM:

Initially, set front panel controls as follows:

- CB/PA VOL — To be fixed at CB position
- PF ATT — Maximum (Fully clockwise)
- Mode switch — "AM"
- Fine Tune — Center (12 o'clock position)
- Squelch — Minimum (Fully counter-clockwise)
- PWR/VOL — Rotate clockwise to switch on, and increase for desired volume.

Squelch Control (AM and SSB Reception)

The squelch control is used for elimination of any annoying background noise when no signals are present. To adjust the SQUELCH control properly during reception, turn up VOLUME until background noise is heard. And rotate the "SQUELCH" slowly clockwise until the background noise just disappears. Such position of SQUELCH is called as "THRESHOLD LEVEL". At this point, the receiver will be quiet under "no-signal" conditions. Speaker must be operated in case that incoming signal overcomes squelch set above threshold level.

Squelch maximum operation voltage: $100\mu V$.

Noise Blanker (AM and SSB reception)

Noise Blanker is specially designed to combat pulsetic noise such as ignition noise. But it is not designed for use against interferences to be caused by neon, atmospheres and various types of electrical machinery.

RF Gain (AM and SSB reception)

Extremely strong signals can be reduced for more comfortable listening by rotating RF gain counter clockwise. Usually, volume to be kept at full clockwise position for best sensitivity.

"S" Meter (AM and SSB reception)

During reception, this meter provides a relative indication of signal strength of a receiving signal. Adjustment to be made in accordance with AM signal, at S9 on $100\mu V$.

Receive Mode SSB

Set all controls initially as follows:

- CB/PA VOL — To be set at CB position.
- RF ATT — Maximum (Fully clockwise)
- Mode switch — To be turned on to USB or LSB.
- Fine Tune — Center (12 O'clock position)
- Squelch — Minimum (Fully counter clockwise)
- PWR/VOL — To be turned on clockwise and switch to be turned on. "VOL" to be set at optional position.

If you are unable to clarify the voice or hear the signal, it is possible that the signal is not on the sideband you are using (Transmitting frequency differs from receiving frequency). Switch the transceiver to the other sideband and repeat the adjustment of the "Fine Tune" control in this mode, until you are able to clarify the voice and make it intelligible. Switch to either the USB or LSB mode. Rotate the "Fine Tune" control Very Slowly on either side of 12 O'clock position (between the 9 o'clock position and the 3 o'clock position). Within this range it should be possible to clarify the sound so that the voice becomes intelligible.

TRANSMIT MODE:

It is illegal to operate the transmitter section of this transceiver prior to receiving a valid station license and call sign. Part 95 of the F.C.C. rules and regulations dealing with the Citizens Radio Service must be obtained, read and understand.

- CB/PA VOL — To be set at CB.
- Mode switch — To be selected LSB, AM or USB.

After you have selected the desired mode of operation by means of the AM-USB-LSB selector switch, simply depress the push-to-talk button on the microphone to transmit. E On transmitting in the AM mode, be sure that RF power output of meter fluctuates in accordance with your voice as you transmit the single sideband signal. This provides AM modulation. When the press-to-talk button is pressed while in the single sideband mode, the meter will produce no reading until you speak into the microphone and provide modulation.

PUBLIC ADDRESS OPERATION

Special provision has been made in this unit for public address (PA) operation.

For PA operation:—

Switch on clockwise "CB/PA VOL" switch and use an external 8-16 ohm speaker connected to "PA SP" Jack. Press the push-to-talk button on the microphone and talk into it setting (4) "VOL" at minimum position. Adjustment of output from PA speaker should be done by "PA VOL". Rotating "VOL" clockwise, and output should be increased.

CRYSTAL FREQUENCY CHART

	11,705M	11,755	11,805	11,855	11,905	11,955
LSB 7,4585M AM. USB 7,4615	1	5	9	13	17	21
LSB 7,4685M AM. USB 7,4715	2	6	10	14	18	22
LSB 7,4785M AM.USB 7,4815	3	7	11	15	19	
LSB 7,4985M AM.USB 7,5015	4	8	12	16	20	23

1 ch	26,965	kHz	13 ch	27,115	kHz
2	26,975		14	27,125	
3	26,985		15	27,135	
4	27,005		16	27,155	
5	27,015		17	27,165	
6	27,025		18	27,175	
7	27,035		19	27,185	
8	27,055		20	27,205	
9	27,065		21	27,215	
10	27,075		22	27,225	
11	27,085		23	27,255	
12	27,105				

TV interference trap:

This transceiver contains a built-in adjustable network in series with the antenna. This network is a filter which offers little opposition to the transmitter frequency but will help to eliminate the second harmonic radiation. This trap to be adjusted by rotating coil on back panel so as to have harmonics of radiator at the minimum position.

MOBILE INSTALLATION

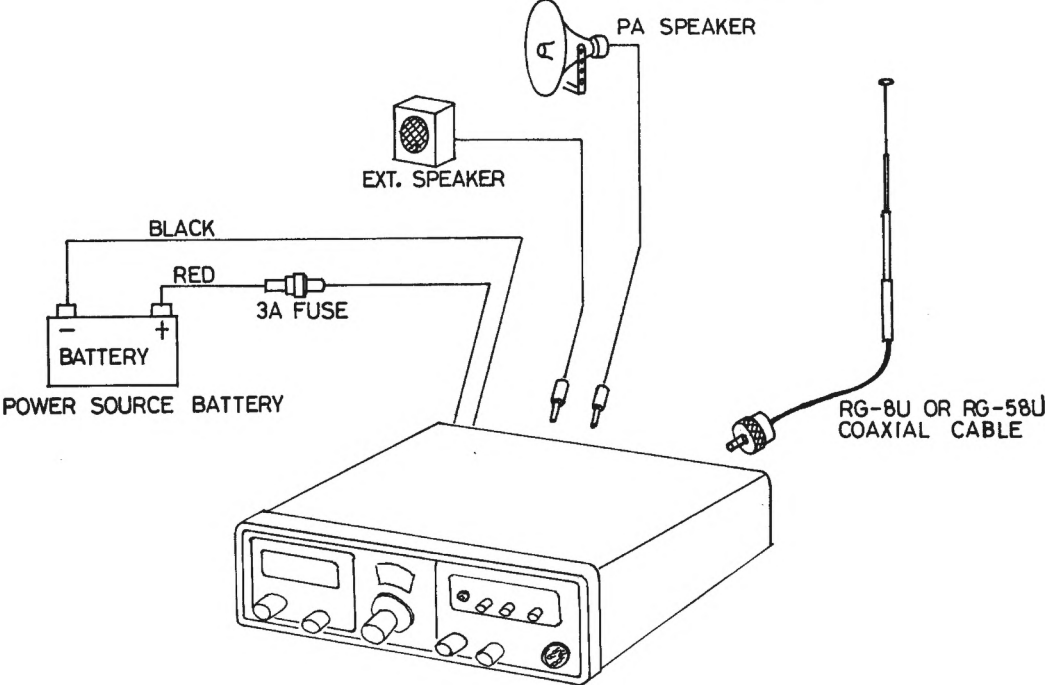
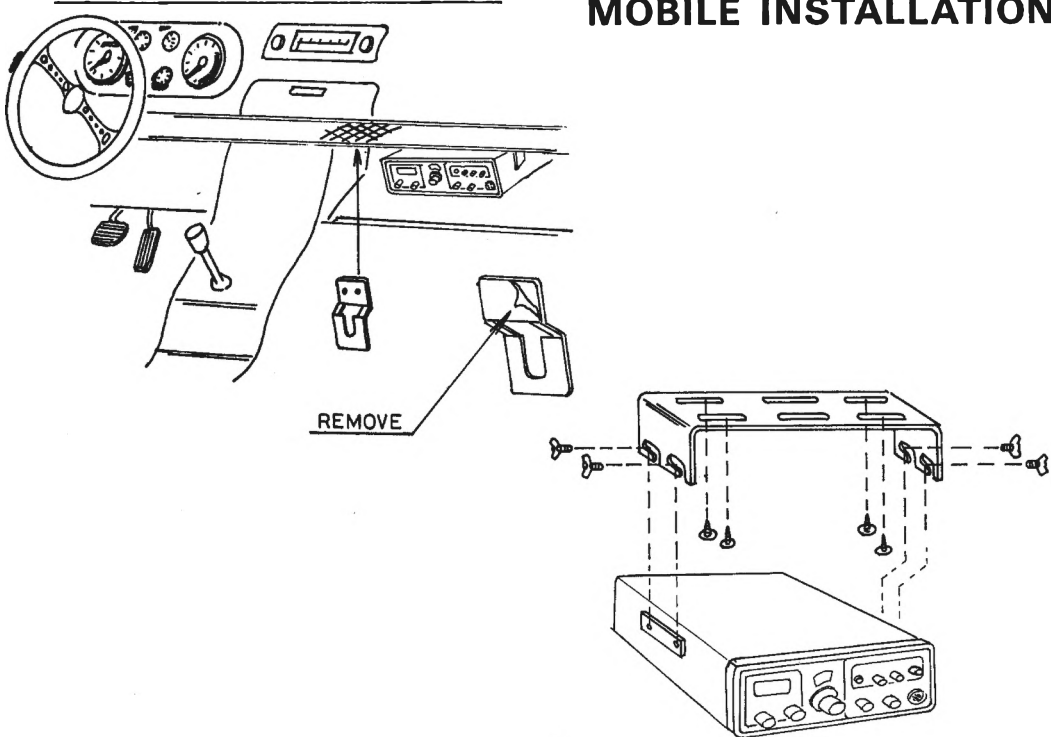

INSTALLATION

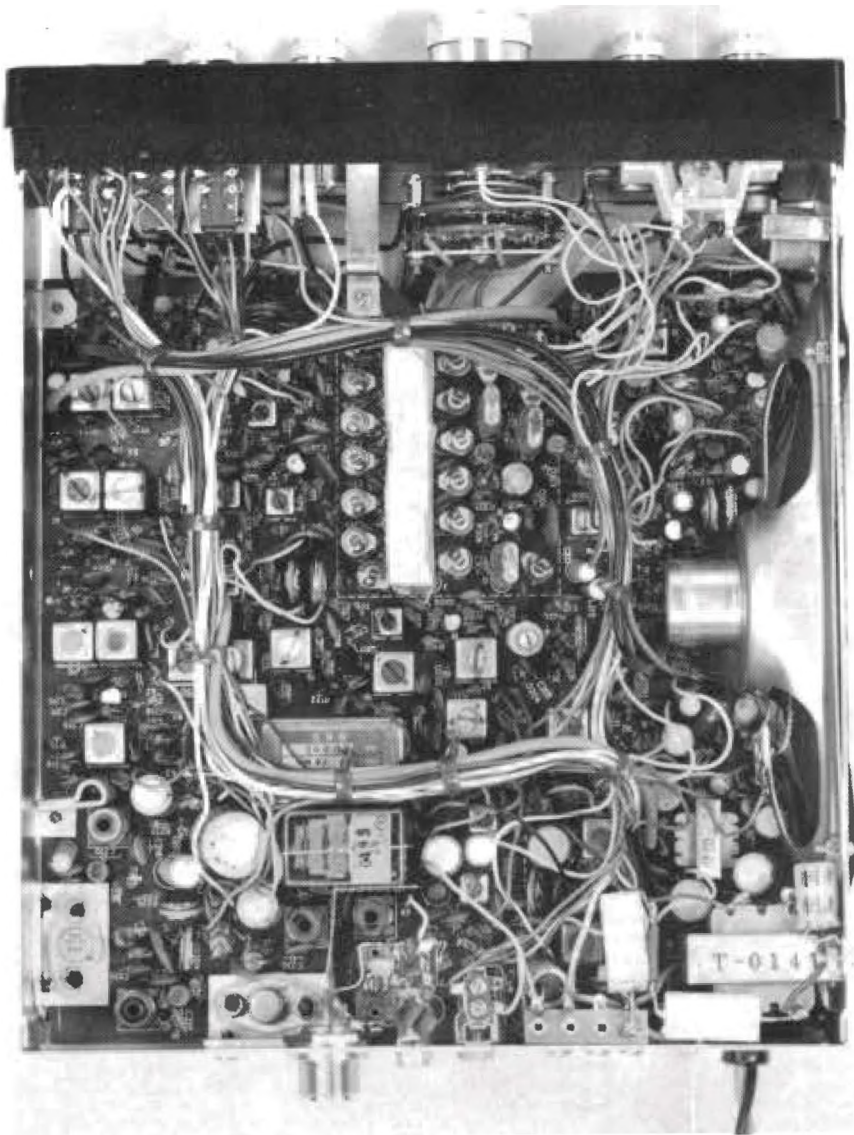

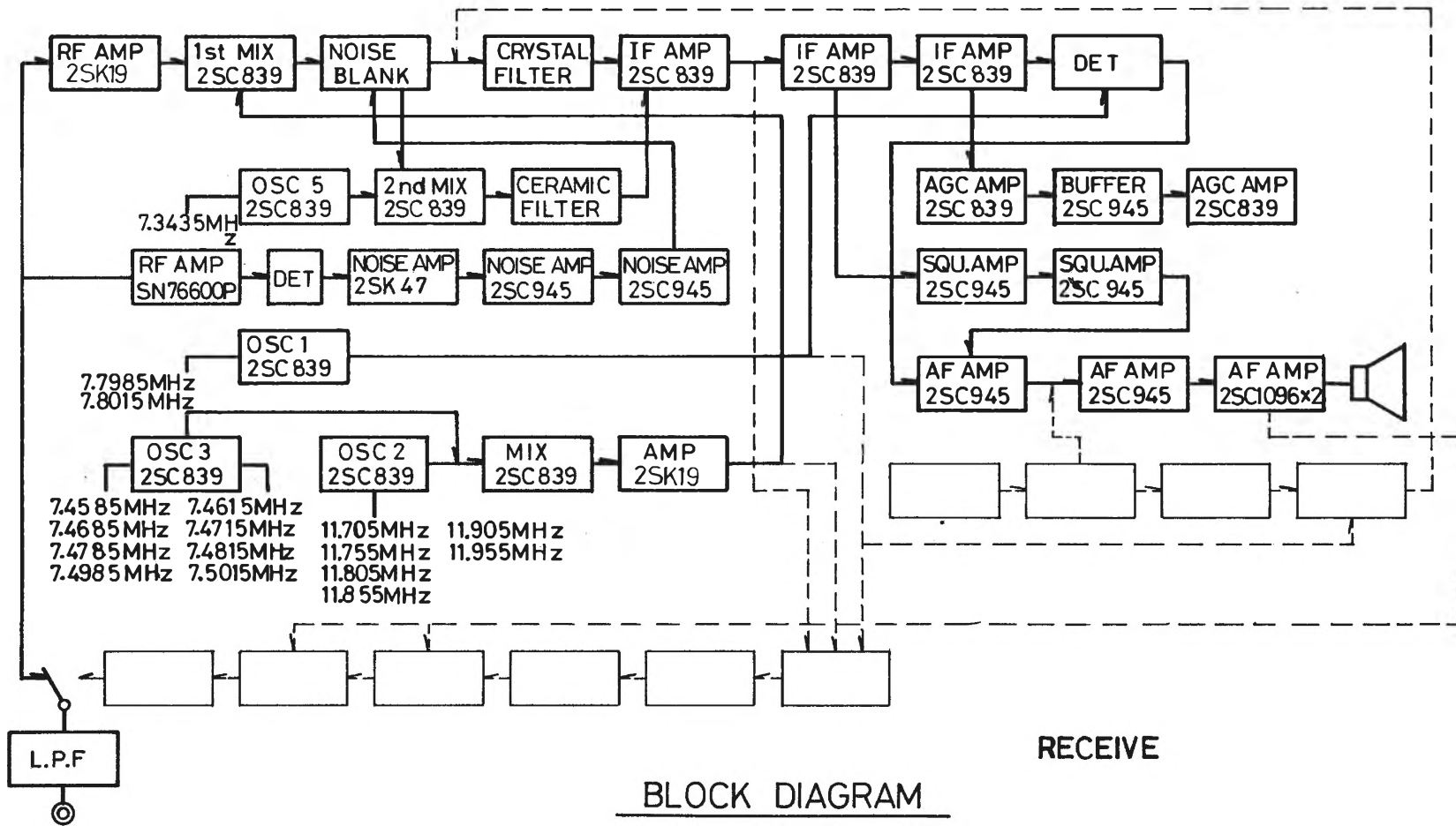

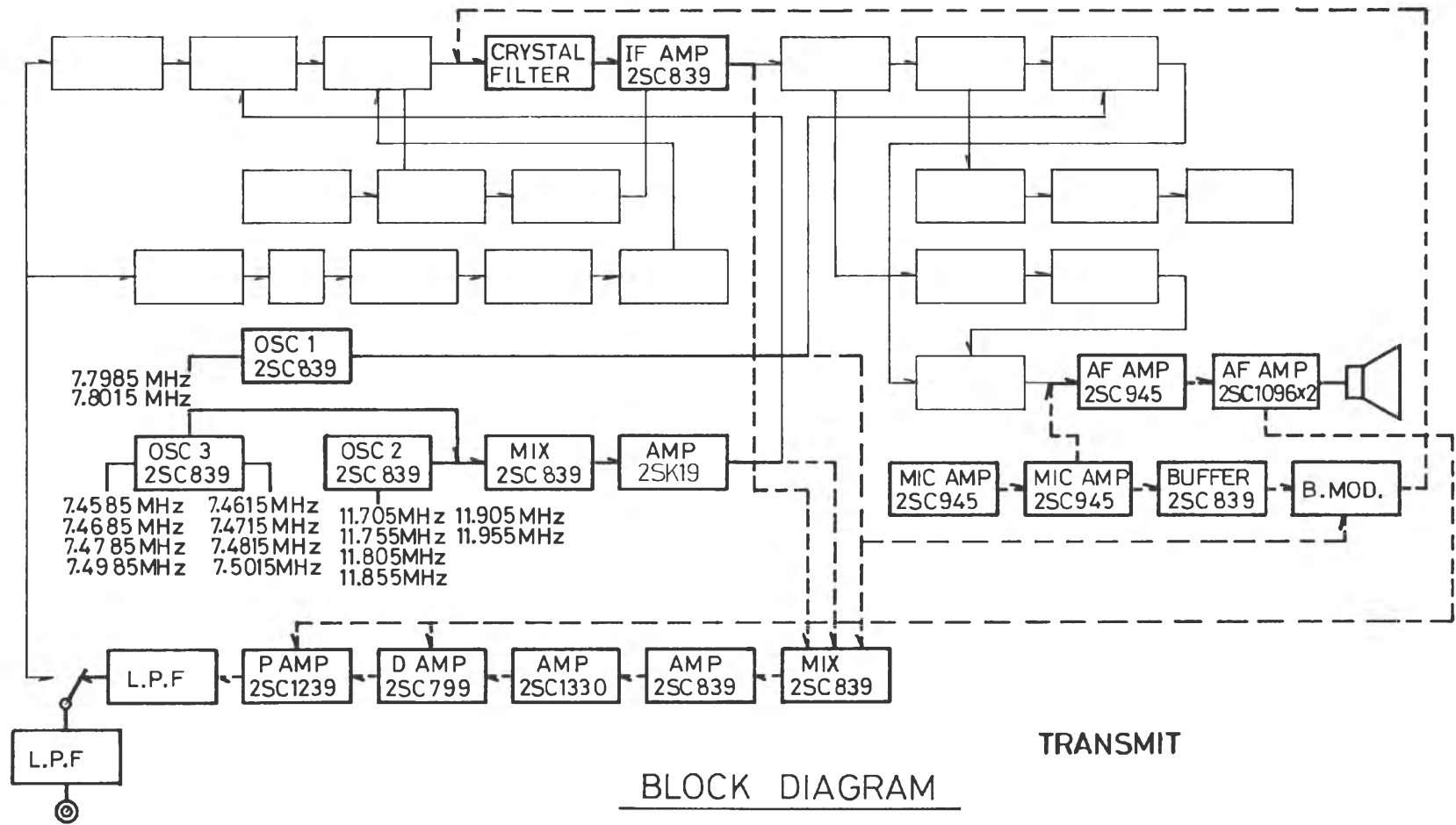

BLOCK DIAGRAM

TRANSMIT

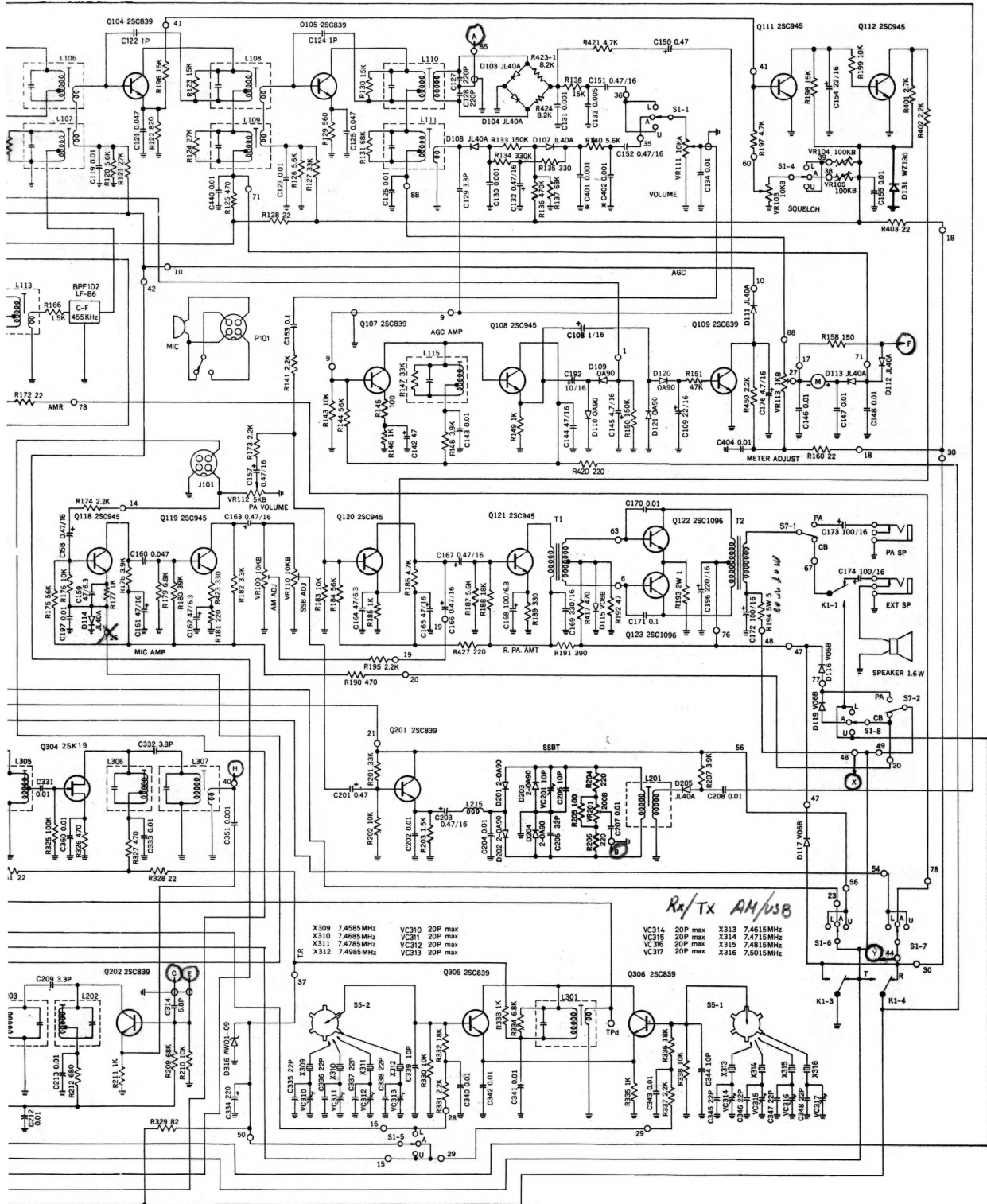

SSB/AM CB TRANSCEIVER

- NOTES:
- 1) ALL RESISTANCE ARE IN OHMS AND WATTAGES OF RESISTOR ARE ± WATT UNLESS OTHERWISE SPECIFIED.
 - 2) CAPACITANCES FOLLOWED BY P ARE IN MICRO-MICRO FARADS OR PICO FARADS OTHERS ARE IN MICRO FARADS AND RATED VOLTAGES OF CAPACITOR ARE 50V UNLESS OTHERWISE SPECIFIED.
 - 3) * SUBJECT TO CHANGE IN INDIVIDUAL UNIT.

