

MODEL M580

AM/FM

INSTRUCTION MANUAL



majör

GENERAL DESCRIPTION

This transceiver is an advanced AM/FM 2-way radio designed primarily for mobile operation. It employs the very latest technology to provide 80 channels of operation by means of digital frequency synthesis with Phase Lock Loop (PLL) circuitry. The use of PLL circuitry assures a precise on-frequency operation on every channel in both AM and FM modes that is unmatched by conventional crystal frequency synthesis.

This transceiver also includes many features which will provide greater operating convenience and assure optimum communications under a wide range of conditions. Other features are:

- 80 channels operation
- AM – FM mode switch for easy selection of operating mode.
- Illuminated meter indicates “S” units

and RF power output.

- LED digital channel read-out.
- Switchable Noise Blanker + ANL for effective reduction of noise.
- Transmit (Tx) indicator lights.
- Variable Squelch control.
- RF Gain control/push-pull band switch (Hi-Lo).
- Built-in ceramic filter helps prevent adjacent channel interference.
- Built-in automatic modulation control circuit.
- Provision for PA operation with volume control.
- External speaker jack.
- Convenient Selective Call input jack.
- Floating chassis for either negative or positive ground mobile operation.
- Push-to-Talk dynamic mic with coiled cord.

TECHNICAL SPECIFICATIONS

GENERAL

| | |
|--------------------|---|
| Circuitry: | Digital Phase Lock Loop synthesizer. |
| Channels: | 80 channels. |
| Mode of Operation: | AM, FM. |
| Power Source: | 13.8V DC [negative or positive ground]. |

RECEIVER SECTION

| | |
|------------------|---|
| Circuit Type: | Dual conversion superheterodyne with RF stage and 455 kHz ceramic-filter. |
| Sensitivity: | 0.7 μ V for 10 dB S/N. |
| Selectivity: | 45 dB down at \pm 10 kHz. |
| Image Rejection: | 40 dB. |

| | |
|--------------------------------------|--|
| Spurious Rejection: | 50 dB. |
| AGC Range [for 10 dB level change] : | 70 dB. |
| Squelch Range: | 0.7 μ V to 500 μ V. |
| IF Frequency: | 1st IF: 10.695 MHz 2nd IF: 455 kHz |
| Audio Output Power: | 3 watts into “EXT. SP” jack [at 8 ohms]. |
| Current Drain: | 300 mA on stand-by [no signal]. |

TRANSMITTER SECTION

| | |
|------------------------------------|----------------------------|
| RF Power Output: | Up to 4 watts at 13.8V DC. |
| Emission: | 6A 3/6F3 |
| Harmonic and Spurious Suppression: | 40 dB. |

AM Modulation: 90% typical.
 FM Deviation: ± 1.5 kHz with 1250 Hz, 20 mV audio.
 Antenna Input Impedance: Nominal 50 ohms.
 Current Drain: 1.6A or less at 13.8V DC.

MISCELLANEOUS

Dimensions [Overall] : 6-1/4"W x 8"D x 2-1/8"H.
 156mmW x 200mm D x 52 mmH.
 Net Weight: 1.5 kilograms/ 3.5 lbs.

FRONT PANEL

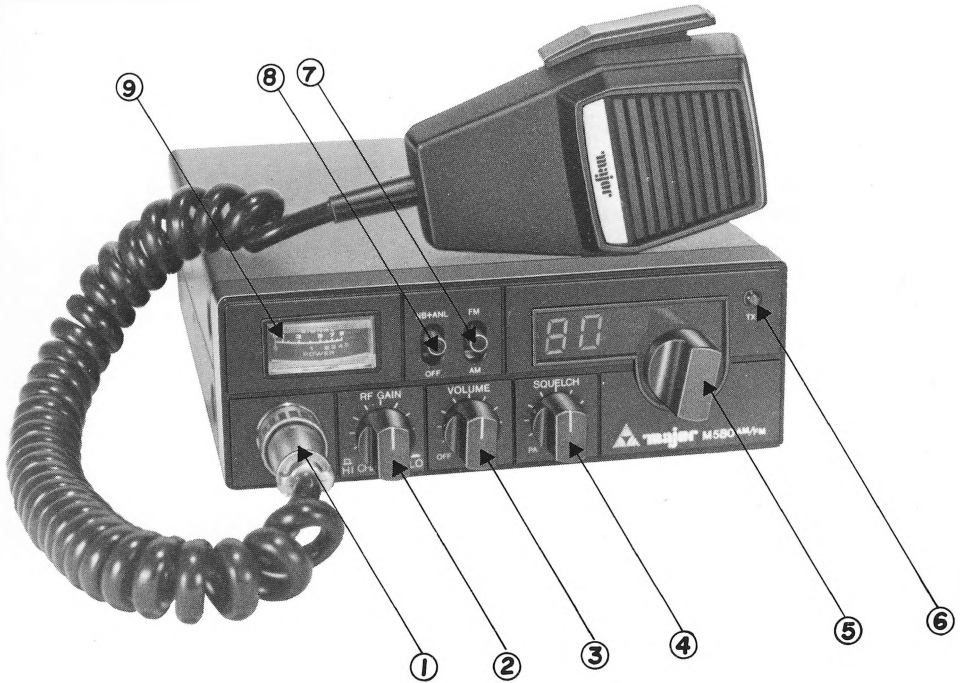

- [1] **MICROPHONE JACK**
4-Pin socket for push-to-talk microphone [supplied].
- [2] **RF GAIN/HI-LO BAND SWITCH**
RF Gain: This control should normally be set to maximum [fully clockwise]. If a storing station blast in, and sound distorted, rotate

counterclockwise for clearer reception. This control does not affect the transmitting output.
Hi-Lo: In this transceiver, 80 channels are divided in two band, high 40 and low 40 frequencies. By pushing this knob in, you can select channels 1 through 40; pulling this out, you

can select channels 41 through 80. Each channel selection is made with the channel selector (5).

[3] **VOLUME/ON-OFF**

Varies the sound output from the speaker. Also incorporates an "on-off" power switch at the extreme counter-clockwise position.

[4] **SQUELCH CONTROL/PA SWITCH**

This control is used to eliminate any annoying background noise when no signals are present. The degree of sensitivity to incoming signals is adjustable. When the Squelch control is rotated to the fully clockwise position, it provides maximum squelch; in the fully counter-clockwise position, it provides minimum squelch. In fully counter-clockwise position past click, the transceiver is converted into PA [Public Address] mode.

[5] **CHANNEL SELECTOR SWITCH**

Rotary switch selects one of 40

channels for both the high band and low band. Channels 1 through 40 are obtained with the Hi-Lo Band switch in Lo (depressed) position, then channels 41 through 80 are obtained with the switch in Hi (released) position.

[6] **TX INDICATOR**

Lights up in the transmit mode.

[7] **AM-FM SWITCH**

Permits you to select the mode of operation, AM or FM.

[8] **NB + ANL SWITCH**

Selects standard ANL and special RF noise silencing circuit to combat ignition noise simultaneously.

[9] **S-PRF METER**

2-function meter indicates relative incoming signal strength in "S" units on upper scale when receiving, lower scale marked POWER indicates the relative RF power output when transmitting.

REAR PANEL

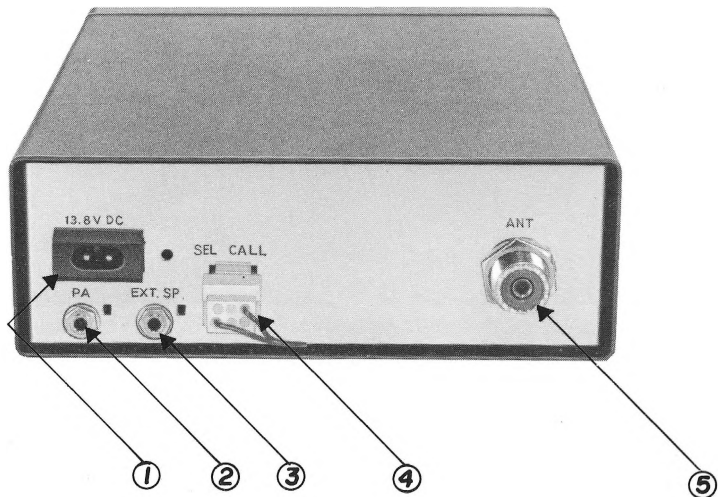

[1] DC POWER SOCKET

13.8V DC power for the transceiver is fed through this socket using DC power cable supplied.

[2] PA JACK

For connection of 8 ohm speaker for PA operation.

[3] EXTERNAL SPEAKER JACK

The impedance of earphones or speakers connected to this jack should be 8 to 16 ohms. Insertion of a plug into this jack automatically

silences the internal speaker.

[4] SELECTIVE CALL JACK

Optional selective call unit plugs into this jack. Consult your dealer for definite information. Do not remove the plug covering this jack unless you are using the selective call unit.

[5] ANTENNA RECEPTACLE

For antenna lead-in cable [RG-58/U] or [RG-8/U] with matching PL-259 type coaxial connector.

MOBILE INSTALLATION

TRANSCEIVER MOUNTING

Before installing the transceiver in a car, truck, boat, etc., be sure to choose a location which is convenient to the operating controls and will not interfere with the normal functions of the driver. The transceiver may be mounted to the underside of the instrument panel of dashboard of a car, truck, etc., by means of the special bracket that is supplied with the transceiver.

Attach the bracket to the underside of the instrument panel or dashboard of the vehicle using the self-tapping screws supplied. Then attach the transceiver to the bracket by means of the two knurled securing screws at the sides.

Tilt the unit upward or downward to the desired angle before tightening the securing screws.

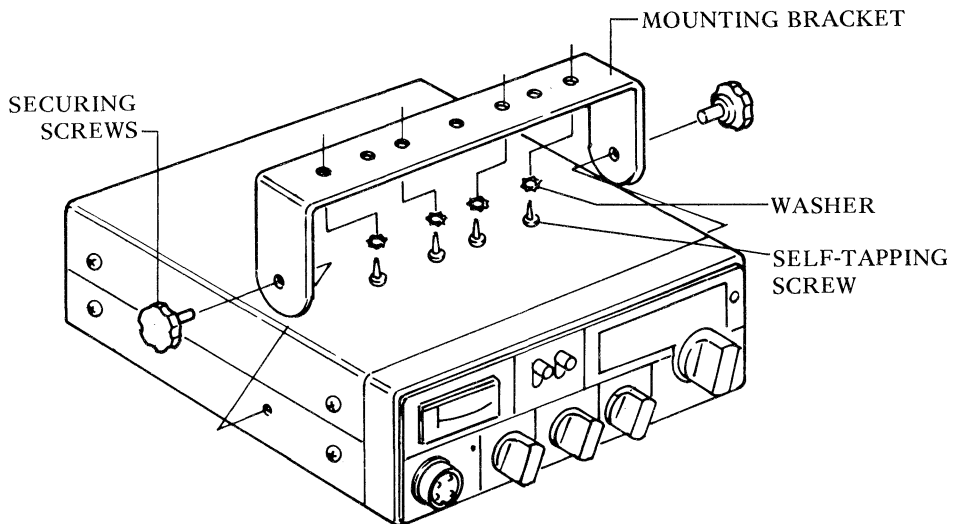

DC POWER CONNECTIONS

The transceiver is designed to operate from a battery source of 13.8 volts DC, in vehicles [or boats] employing either negative or positive ground electrical system. The fused DC power cable supplied is used to make the necessary power connection to the transceiver. The red [fused] lead is connected to the positive [+] side of the electrical system in the vehicle, and the black lead is connected to the negative [-] side of the system.

In a negative ground vehicle: Connect the red lead to the "hot" point in the electrical system [battery positive], and the black lead to the metal firewall or any other point that is connected to the vehicle chassis [battery negative].

In a positive ground vehicle: Connect the black lead to the "hot" point in the electrical system [battery negative], and the red lead to the metal firewall or any other point that is connected to the vehicle chassis [battery positive].

A suitable point in the vehicle for connection to the "hot" battery side can usually be found on the fuse block. Since the transceiver draws a maximum of only 1.6 amperes of current, you can use a terminal which supplies power to the car radio or other accessory [use the unfused input side since the DC power cable is equipped with its own fuse]. To simplify connection to this terminal, attach an alligator [spring] clip to the power

CB ANTENNAS

The results obtained with your transceiver will be greatly determined by the efficiency of the antenna system used.

Due to the complexity of the subject, it is not within the scope of this manual to

OPERATION INSTRUCTIONS

Make sure the transceiver is properly

lead first and then clamp it onto the terminal selected. Note that the connection to this point will ensure that DC power to the transceiver is automatically cut off when the vehicle ignition is turned off.

ANTENNA CONNECTION

The lead-in cable from the CB antenna should be terminated with a PL-259 type male connector. Attach to the matching antenna input connector at the rear of the transceiver.

RG-58/U cable is generally used to connect the CB antenna to the transceiver. The cable should be terminated with a PL-259 connector for connection to the antenna input on the transceiver.

In a base station installation, an exceptionally long lead-in cable may be required. When lengths of over 50 feet [15 meters] are necessary, RG-8/U coaxial cable is more suitable than RG-58/U since it offers lower loss.

MICROPHONE BRACKET

This small size of the transceiver prohibits mounting a microphone bracket directly to the chassis. We recommend, therefore, that the microphone bracket be attached to the dashboard of the vehicle or in any other convenient location. If one desires to do this without drilling holes, a magnetic mounting plate may be used and the microphone bracket attached to it.

provide detailed information on antenna systems. We suggest that you purchase one of the numerous books available which covers this subject in greater detail.

installed as indicated previously, and that

the antenna and power source are connected. If you have not already done so, plug in the microphone.

RECEIVING

1. Rotate the Squelch control 4) to about 9 o'clock position initially.
2. Select the AM or FM mode by the AM-FM switch 7), as you desire.
3. Select desired channel by both the Hi-Lo Band switch 2) and the Channel selector switch 5) as indicated by the LED digital readout.
4. Set the NB + ANL Switch 8) to the OFF position initially.
5. Rotate the RF Gain control 2) to maximum [fully clockwise].
6. Rotate the Volume/On-Off control 3) clockwise to apply power to the transceiver.

Since the transceiver is fully transistorized, operation will be instantaneous.

Continue rotating the Volume/On-Off control clockwise to provide a comfortable listening level.

TRANSMITTING

WARNING: NEVER ATTEMPT TO TRANSMIT WITHOUT AN ANTENNA OR LOAD.

To transmit, simply depress the push-to-

talk bar on the microphone. The TX Indicator Light 6) will come on as you depress the push-to-talk bar. Hold the microphone 3 to 4 inches from the mouth and slightly to one side so that the voice does not project directly into the microphone. Speak at a normal level — there is no need to shout. A designed feature of this transceiver is that high average modulation can be achieved easily at normal voice levels.

PA [PUBLIC ADDRESS] OPERATION

For PA operation, you should use an external 8 to 16 ohm speaker connected to the "PA" jack [located at the rear of the transceiver]. The recommended plug for the "PA" jack is a subminiature phone plug. To set the transceiver to the PA mode, set the Squelch control to the full counter-clockwise position (past click), then press the push-to-talk bar on the microphone and talk into it — your voice will be heard through the PA speaker.

To reduce acoustic feedback when the PA speaker is mounted on a car or truck, you may have to close the vehicle windows, or reduce the volume as necessary to stop any feedback that may occur.

FREQUENCIES

Your transceiver is capable of operation on all frequencies as listed below:

| Channel | Channel Frequency in MHz | Channel | Channel Frequency in MHz | Channel | Channel Frequency in MHz | Channel | Channel Frequency in MHz |
|---------|--------------------------|---------|--------------------------|---------|--------------------------|---------|--------------------------|
| 1 | 26.965 | 21 | 27.215 | 41 | 27.415 | 61 | 27.665 |
| 2 | 26.975 | 22 | 27.225 | 42 | 27.425 | 62 | 27.675 |
| 3 | 26.985 | 23 | 27.255 | 43 | 27.435 | 63 | 27.705 |
| 4 | 27.005 | 24 | 27.235 | 44 | 27.455 | 64 | 27.685 |
| 5 | 27.015 | 25 | 27.245 | 45 | 27.465 | 65 | 27.695 |
| 6 | 27.025 | 26 | 27.265 | 46 | 27.475 | 66 | 27.715 |
| 7 | 27.035 | 27 | 27.275 | 47 | 27.485 | 67 | 27.725 |
| 8 | 27.055 | 28 | 27.285 | 48 | 27.505 | 68 | 27.735 |
| 9 | 27.065 | 29 | 27.295 | 49 | 27.515 | 69 | 27.745 |
| 10 | 27.075 | 30 | 27.305 | 50 | 27.525 | 70 | 27.755 |
| 11 | 27.085 | 31 | 27.315 | 51 | 27.535 | 71 | 27.765 |
| 12 | 27.105 | 32 | 27.325 | 52 | 27.555 | 72 | 27.775 |
| 13 | 27.115 | 33 | 27.335 | 53 | 27.565 | 73 | 27.785 |
| 14 | 27.125 | 34 | 27.345 | 54 | 27.575 | 74 | 27.795 |
| 15 | 27.135 | 35 | 27.355 | 55 | 27.585 | 75 | 27.805 |
| 16 | 27.155 | 36 | 27.365 | 56 | 27.605 | 76 | 27.815 |
| 17 | 27.165 | 37 | 27.375 | 57 | 27.615 | 77 | 27.825 |
| 18 | 27.175 | 38 | 27.385 | 58 | 27.625 | 78 | 27.835 |
| 19 | 27.185 | 39 | 27.395 | 59 | 27.635 | 79 | 27.845 |
| 20 | 27.205 | 40 | 27.405 | 60 | 27.655 | 80 | 27.855 |

Courtesy AC5XP

SCHEMATIC DIAGRAM

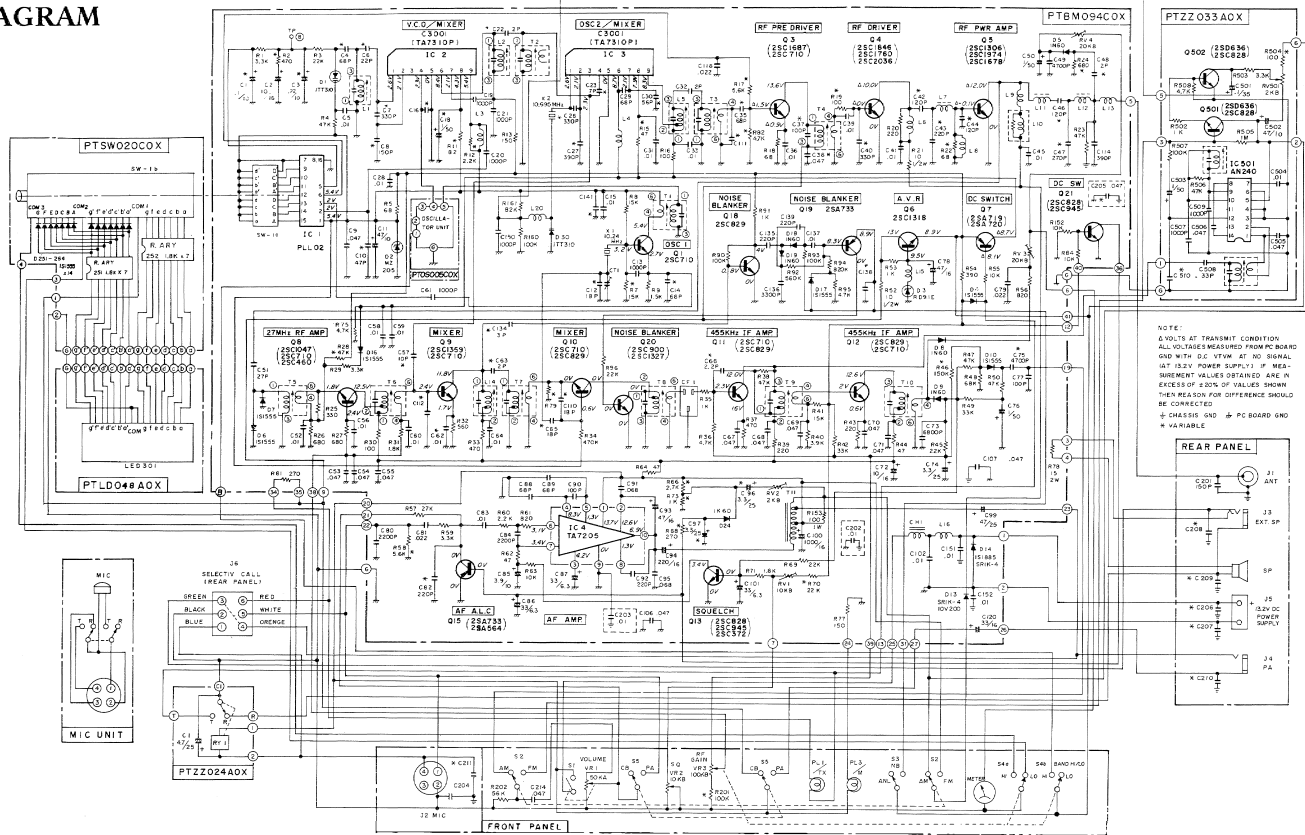

NOTE:
 1. 6 VOLTS AT TRANSMIT CONDITION
 ALL VOLTAGES MEASURED FROM PC BOARD
 GND WITH DC RTVM AT NO SIGNAL
 SAT 100V POWER SUPPLY. IF MEASUREMENT
 VALUES OBTAINED ARE IN
 EXCESS OF 20% OF VALUES SHOWN
 THEN REASON FOR DIFFERENCE SHOULD
 BE CORRECTED

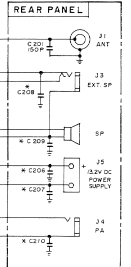

TRANSFORMER TYPICAL OF INFORMATION

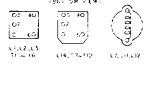

BOTTOM VIEW

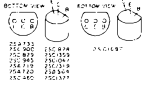

FRONT VIEW



RIGHT VIEW

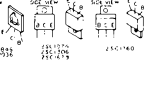

LEFT VIEW

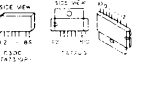

TOP VIEW



SEE L-1





MAJOR ACOUSTICS CORPORATION