

Beam Power Tube

CERMOLOX[®]

17 KILOWATTS PEAK POWER OUTPUT AT 1215 Mc

FORCED-AIR COOLED
INTEGRAL RADIATORHIGH GAIN-BANDWIDTH PRODUCTS
MATRIX-TYPE CATHODE

For Pulsed RF Amplifier Service in Compact Aircraft, Mobile, and Stationary Equipment in the UHF Frequency Range

GENERAL DATA

Electrical:

Heater, for Matrix-Type, Oxide-Coated, Unipotential Cathode:

Voltage (AC or DC) ^a	6.3	volts
Current at heater volts = 6.3	3.2	volts
Minimum heating time.	60	sec

Direct Interelectrode Capacitances:^b

Grid No.1 to plate.	0.13 max.	pf
Grid No.1 to cathode & heater	15	pf
Plate to cathode & heater	0.019 max.	pf
Grid No.1 to grid No.2.	20	pf
Grid No.2 to plate.	4.6	pf
Grid No.2 to cathode & heater	1.30 max.	pf

Mechanical:

Operating Position.	Any
Overall Length.	2.445" ± 0.075"
Greatest Diameter (See <i>Dimensional Outline</i>)	1.250" ± 0.015"
Weight (Approx.).	2 oz
Radiator.	Integral part of tube
Terminal Connections (See <i>Dimensional Outline</i>):	

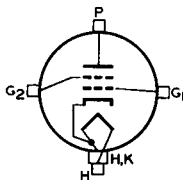
G₁ - Grid-No.1-
Terminal
Contact
SurfaceG₂ - Grid-No.2-
Terminal
Contact
SurfaceH - Heater-
Terminal
Contact
SurfaceH, K - Heater- &
Cathode-
Terminal
Contact
SurfaceP - Plate-
Terminal
Contact
Surface

Thermal:

Plate, Grid No.2, Grid No.1, Cathode, and Heater Temperature ^c	250 max.	°C
Radiator Core Temperature ^c	250 max.	°C



Air Flow:

Through radiator — Adequate air flow to limit the radiator core temperature to 250° C should be delivered by a blower across the radiator before and during the application of plate, grid-No.2, and grid-No.1 voltages. Typical values of air flow directed across the radiator versus plate dissipation are shown in accompanying *Typical-Cooling-Requirements (With and without cowling)* curves.

To Plate, Grid-No.2, Grid-No.1, Cathode, and Heater Terminals — A sufficient quantity of air should flow across each of these terminals so that their temperature does not exceed the specified maximum value of 250° C.

During Standby Operation — Cooling air is not usually required when only heater voltage is applied to the tube.

Plate Power, Grid-No.2 Power, Heater Power, and Air Flow — These may be removed simultaneously.

At Sea Level — Cooling requirements, with air flow directed through the radiator as shown in accompanying *Typical-Cooling-Requirements* curve, may be met by use of the following blowers and associated motors manufactured by Rotron Manufacturing Company Incorporated, Woodstock, New York, or equivalent:

For 100% Plate Dissipation:

Blower Model No.	KS-2505	AS-2505	AXIMAX I	AXIMAX I
Motor Model No.	165AS	323JS	464YS	499JS
Phase (ϕ)	1	3	1	3
Frequency (cps)	60	60	400	400
Voltage (v)	115	220	115	200

For 80% Plate Dissipation:

Blower Model No.	KS-202	AS-202	AXIXAX I	AXIMAX I
Motor Model No.	92AS	323JS	464YS	499JS
Phase (ϕ)	1	3	1	3
Frequency (cps)	60	60	400	400
Voltage (v)	115	220	115	200

For 60% Plate Dissipation:

Blower Model No.	KS-1504	AS-1504	AXIMAX I	AXIMAX I
Motor Model No.	92AS	323JS	464YS	499JS
Phase (ϕ)	1	3	1	3
Frequency (cps)	60	60	400	400
Voltage (v)	115	220	115	200

PULSED RF AMPLIFIER

Maximum Ratings, Absolute-Maximum Values:

For frequencies up to 1215 Mc and for a maximum "on" time^d as specified in any 1000-microsecond interval.

PEAK POSITIVE-PULSE PLATE VOLTAGE . . .	7000 max.	volts
DC PLATE VOLTAGE	4000 max.	volts
DC OR PEAK POSITIVE-PULSE GRID-No.2 VOLTAGE	1000 max.	volts
DC OR PEAK POSITIVE-PULSE GRID-No.2 TO GRID-No.1 VOLTAGE	1000 max.	volts
DC NEGATIVE OR PEAK NEGATIVE-PULSE GRID-No.1 VOLTAGE	200 max.	volts



DC PLATE CURRENT DURING PULSE:		
With 10-microsecond "ON" time	4.5 max.	amp
With 5-microsecond "ON" time.	6 max.	amp
DC PLATE CURRENT:		
With 10-microsecond "ON" time	0.070 max.	amp
With 5-microsecond "ON" time.	0.050 max.	amp
GRID-No.2 INPUT ^e (Average).	10 max.	watts
GRID-No.1 INPUT (Average)	5 max.	watts
PLATE DISSIPATION (Average)	125 max.	watts

Typical Operation:

In a cathode-drive circuit, with rectangular waveshape pulses of 5-microsecond duration and duty factor of 0.005, at 1215 Mc.

With pulsed rf drive and pulsed grid-No.2 supply voltage

DC Plate Voltage.	4000	volts
Peak Positive-Pulse Grid-No.2 Voltage	1000	volts
DC Grid-No.2 Voltage.	-90	volts
DC Grid-No.1 Voltage.	0	volts
Peak Plate Current.	6	amp
DC Plate Current.	0.030	amp
DC Grid-No.2 Current.	0.003	amp
DC Grid-No.1 Current.	0.010	amp
Peak Driver Power Output (Approx.) ^f	1250	watts
Output-Circuit Efficiency (Approx.)	93	%
Useful Peak Pulse Power Output (Approx.) ^g	10000	watts

Maximum Circuit Values:

Grid-No.1 Circuit Resistance.	30000 max.	ohms
Grid-No.2 Circuit Impedance	10000 max.	ohms
Plate Circuit Impedance	h	

With pulsed rf drive, pulsed grid-No.2 supply voltage, and pulsed plate supply voltage

Peak Positive-Pulse Plate Voltage	7000	volts
Peak Positive-Pulse Grid-No.2 Voltage	1000	volts
DC Grid-No.1 Voltage.	0	volts
Peak Plate Current.	6	amp
DC Plate Current.	0.030	amp
DC Grid-No.2 Current.	0.003	amp
DC Grid-No.1 Current.	0.010	amp
Peak Driver Power Output (Approx.) ^f	1250	watts
Output-Circuit Efficiency (Approx.)	87	%
Useful Peak Pulse Power Output (Approx.) ^{g,j}	17000	watts ←

Maximum Circuit Values:

Grid-No.1 Circuit Resistance.	30000 max.	ohms
Grid-No.2 Circuit Impedance	10000 max.	ohms
Plate Circuit Impedance	h	

← Indicates a change.



- a See *Operating Considerations* under *Heater*.
- b Measured with special shield adapter.
- c See *Operating Considerations* under *Temperature* and also *Dimensional Outline* for temperature measurement points.
- d "On" time is defined as the sum of the duration of all the individual pulses which occur during an indicated interval. *Pulse duration* is defined as the time interval between the two points on the pulse at which the instantaneous value is 70 per cent of the peak power value. *Peak value* is defined as the maximum value of a smooth curve through the average of the fluctuations over the top portions of the pulse.
Duty factor is defined as the ratio of "on" time to indicated interval.
- e See *Operating Considerations* under *Grid No.2*.
- f Driver power output includes circuit losses and feed-through power. It is the actual power measured at input to the tube drive circuit. It will vary with frequency of operation and driver circuitry.
- g Measured in the load of a coaxial-cavity circuit having the output circuit efficiency specified.
- h See *Operating Considerations* under *Precautions*.
- j For Minimum Useful Power Output value, see *Characteristics Range Values, Test No.9*.

CHARACTERISTICS RANGE VALUES

Test No.	Note	Min.	Max.	
1. Heater Current	1	2.90	3.55	amp
2. Direct Interelectrode Capacitances:				
Grid No.1 to plate	2	-	0.13	pf
Grid No.1 to cathode & heater	2	13.5	16.5	pf
Plate to cathode & heater	2	-	0.019	pf
Grid No.1 to grid No.2	2	16.8	22.2	pf
Grid No.2 to plate	2	3.6	5.6	pf
Grid No.2 to cathode & heater	2	-	1.30	pf
3. Grid-No.1 Voltage (1)	1,3	-11.5	-24.5	volts
4. Grid-No.1 Voltage (2)	4	-30	-62	volts
5. Grid-No.1 Cutoff Voltage	1,5	-	-95	volts
6. Reverse Grid-No.1 Current	1,3	-	-20	μa
7. Grid-No.2 Current	1,4	-5	+11	ma
8. Interelectrode Leakage Resistance:				
Between plate and all other electrodes	6	10	-	megohms
Between any two electrodes except plate	6	1	-	megohm
9. Useful Peak Pulse Power Output	7	15000	-	watts

Note 1: With 6.3 volts ac or dc on heater.

Note 2: Measured with special shield adapter.

Note 3: With dc plate voltage of 2500 volts, dc grid-No.2 voltage of 300 volts, and dc grid-No.1 voltage adjusted to give a dc plate current of 50 ma.

Note 4: With dc plate voltage of 2500 volts, dc grid-No.2 voltage of 700 volts, and dc grid-No.1 voltage adjusted to give a dc plate current of 50 ma.

Note 5: With dc plate voltage of 4000 volts, dc grid-No.2 voltage of 700 volts, and dc grid-No.1 voltage adjusted to give a dc plate current of 5 ma.



Note 6: Under conditions with tube at 20° to 30° C without any voltages applied to the tube, the resistance between the two electrodes is measured with a 200-volt Megger-type ohmmeter having an internal impedance of 1.0 megohm.

Note 7: In a plate-and-screen-pulsed cathode-drive cavity at 1215 Mc and for conditions with 6.3 volts ac or dc on heater, peak positive-pulse plate voltage of 7000 volts and a maximum driver power output of 1500 peak watts, peak positive-pulse grid-No.2 voltage of 1000 volts, grid-No.1 voltage of 0 volts, and tuning circuit and drive are adjusted for maximum power output with peak plate current not to exceed 6 amperes. Pulse duration is 5 microseconds and duty factor is 0.005.

OPERATING CONSIDERATIONS

Heater

The heater of the 8227 should be operated at constant voltage rather than constant current. The rated heater voltage of 6.3 volts should be applied for 60 seconds to allow the cathode to reach normal operating temperature before voltages are applied to other electrodes.

The life of the cathode can be conserved by operating at the lowest heater voltage which will give adequate but not excessive emission to enable the 8227 to give the desired power output. Good regulation of the heater voltage is in general economically advantageous from the viewpoint of tube life; in no case should the voltage fluctuations be more than 5%.

The cathode may be subjected to back bombardment as the frequency is increased with resultant increase in temperature. When the duty factor is small, back bombardment normally need not be considered. When high duty factors are encountered, the necessary heater voltage should be determined as follows: with all other voltages constant, the minimum heater-supply voltage conditions at this reduced value shall provide satisfactory tube performance; any further reduction will show some degradation.

Temperature

The maximum radiator core or electrode temperature of 250° C is a tube rating and is to be observed in the same manner as other ratings. The temperature may be measured with temperature-sensitive paint, such as Tempilaq. This paint is manufactured in the form of liquid or stick by the Tempil Corporation, 132 West 22nd Street, New York 11, N. Y.

Grid No.2

Grid-No.2 current is composed of a positive-current component resulting from cathode emission to grid No.2 and a negative-current component resulting from secondary emission phenomena. Because it is the net result of these component currents which is read on a meter in the grid-No.2 circuit, grid-No.2 dissipation cannot be accurately determined. Operation similar to conditions given under *Typical Operation* in the tabulated data section will minimize the possibility of exceeding maximum grid-No.2 input rating.



The grid-No.2 circuit must be capable of maintaining the proper grid-No.2 voltage in the presence of moderate average negative dc current as well as normal values of average positive current. Complete protection can be achieved by the use of a well-regulated power supply, a grid-No.2-to-ground impedance that is low enough to prevent gradual build-up of grid-No.2 voltage and/or catastrophic build-up (runaway) under negative current conditions and a current overload relay to protect the grid-No.2 against positive or negative current of the order of 10 ma.

Standby Operation

During long or frequent standby periods, the 8227 may be operated at decreased heater voltage to conserve life. It is recommended that the heater voltage be reduced to 80% of normal during standby periods up to 2 hours. For longer periods, the heater voltage should be turned off.

Precautions

In beam power tubes with closely spaced electrodes, such as the 8227, extremely high voltage gradients occur even with moderate tube operating voltages. Any arcover between electrodes may be destructive. A series impedance in the plate lead is recommended. The resultant plate impedance giving a plate-voltage-supply regulation of no better than 10% is usually sufficient.

Protective devices should be used to protect not only the plate but also grid No.2 against overload. In order to prevent excessive plate current flow and resultant overheating of the tube, the common ground lead of the plate circuit should be connected in series with the coil of an instantaneous overload relay. This relay should be adjusted to remove the dc plate voltage and dc grid-No.2 voltage when the average value of plate current reaches a value slightly higher than normal plate current. A protective device in the grid-No.2 supply should remove the grid-No.2 voltage when the dc grid-No.2 current reaches a value slightly higher than normal.

The rated plate and grid-No.2 voltages of this tube are extremely dangerous. Great care should be taken during the adjustment of circuits. The tube and its associated apparatus, especially all parts which may be at high potential above ground, should be housed in a protective enclosure. The protective housing should be designed with interlocks so that personnel can not possibly come in contact with any high-potential point in the electrical system. The interlock device should function to break the primary circuit of the high-voltage supplies when any gate or door of the protective housing is opened, and should prevent the closing of the primary circuit until the door is again locked.

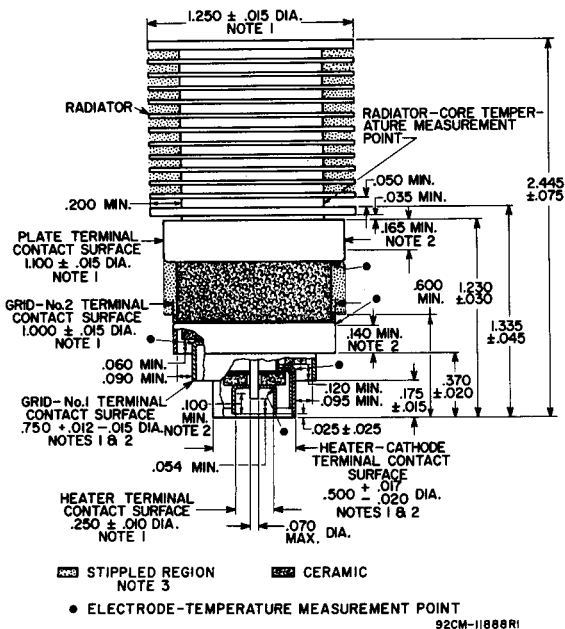

ALL DIMENSIONS IN INCHES

NOTE 1: SEE SKETCH G₁ FOR THE MAXIMUM DIAMETRICAL SPACE REQUIRED BY THE 8227 BASED UPON THE DIAMETER AND ECCENTRICITY OF RADIATOR BAND AND OF EACH RING TERMINAL.

NOTE 2: THE DIAMETER OF THE TERMINAL IS HELD TO THE INDICATED VALUE ONLY OVER THE CONTACT SURFACE LENGTH. THE CONTACT SURFACE LENGTH OF THE HEATER-CATHODE AND GRID-No.1 TERMINALS EXTENDS FROM THE EDGE OF ITS TERMINAL TO THE PLANE COINCIDENT WITH THE EDGE OF THE ADJACENT LARGER TERMINAL.

NOTE 3: KEEP ALL STIPPLED REGIONS CLEAR. DO NOT ALLOW CONTACTS OR CIRCUIT COMPONENTS TO PROTRUDE INTO THESE ANNULAR REGIONS.

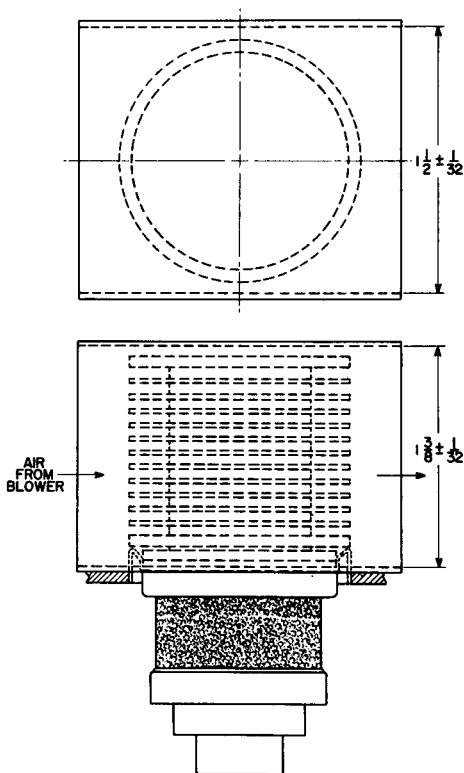

RECOMMENDED COWLING
FOR DIRECTING AIR FLOW ACROSS RADIATOR

92CM-11894

ALL DIMENSIONS IN INCHES

PREFERRED MOUNTING ARRANGEMENT
& LAYOUT OF ASSOCIATED CONTACTS

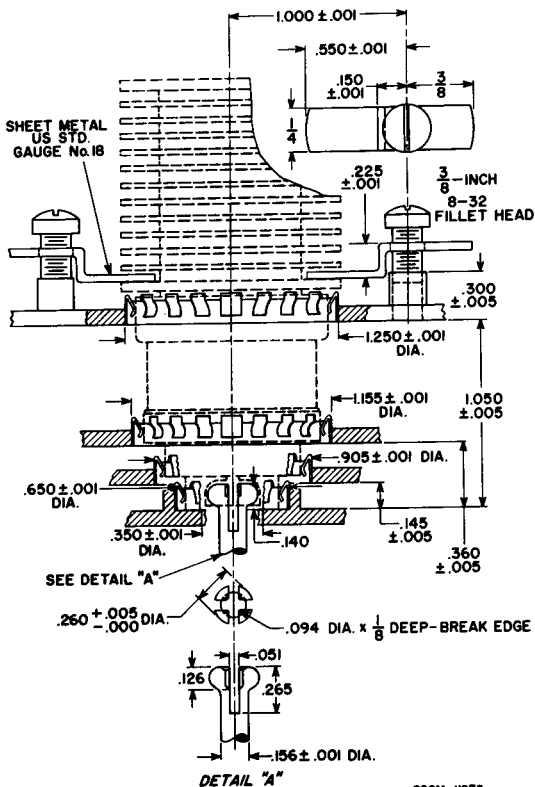

ALL DIMENSIONS IN INCHES

NOTE: ALL FINGER STOCK (No.97-380) MADE BY INSTRUMENT
SPECIALTIES COMPANY, LITTLE FALLS, NEW JERSEY.



SKETCH G1

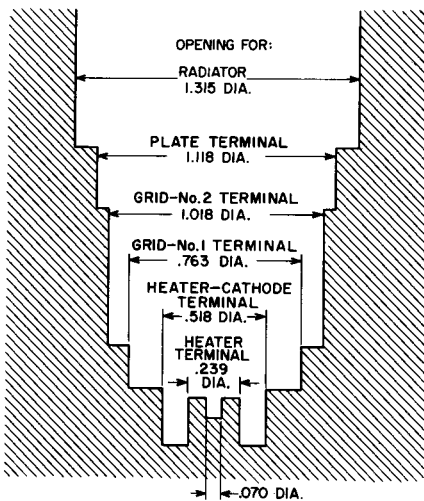

92CS-11895

ALL DIMENSIONS IN INCHES

TYPICAL COOLING REQUIREMENTS With Cowling

AIR FLOW DIRECTED THROUGH RADIATOR WITH COWLING AS SHOWN IN ACCOMPANYING DIAGRAM.

CURVE	PRESSURE DROP—INCHES OF WATER
A, B, C, D, E	LESS THAN 0.1

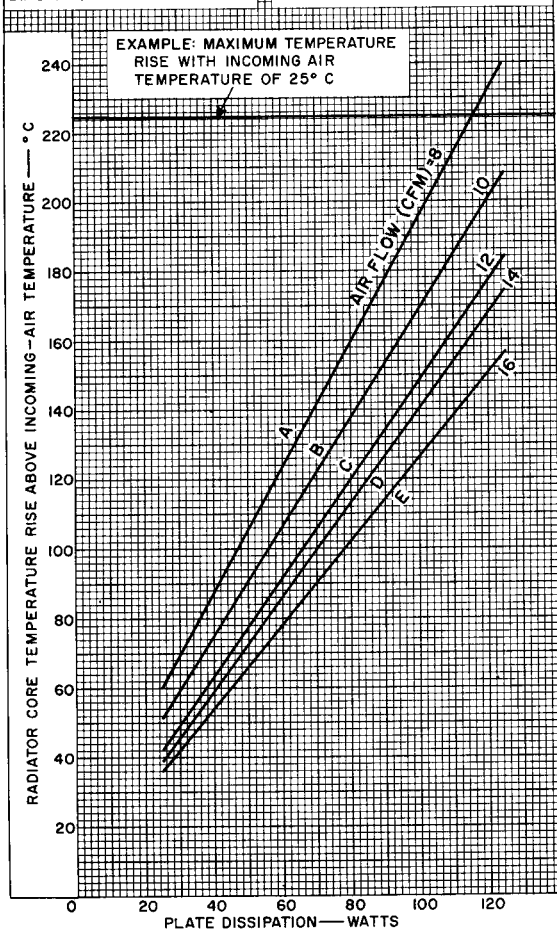

92CM-11999



TYPICAL COOLING REQUIREMENTS Without Cowling

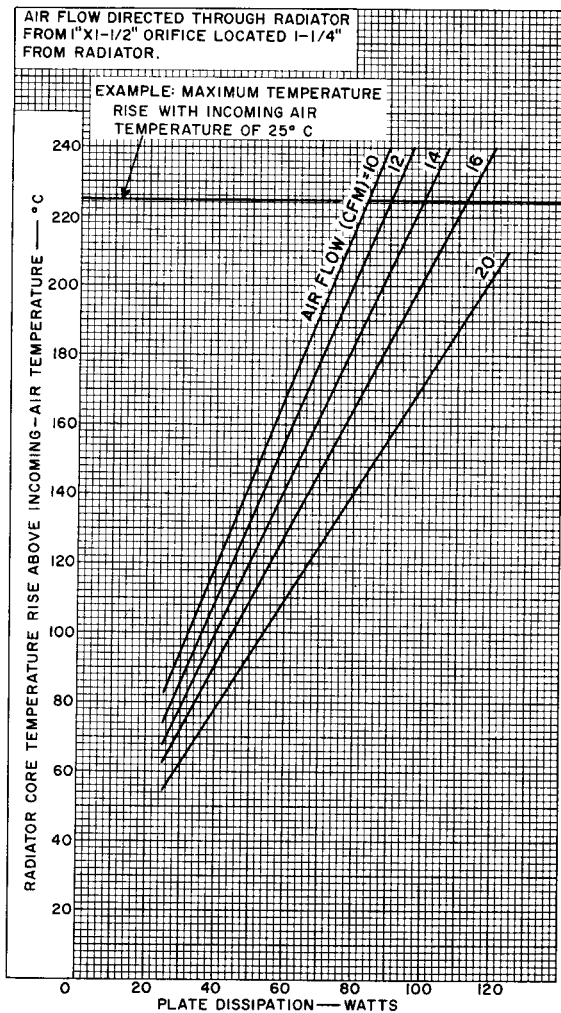

92CM-12000



TYPICAL PLATE CHARACTERISTICS

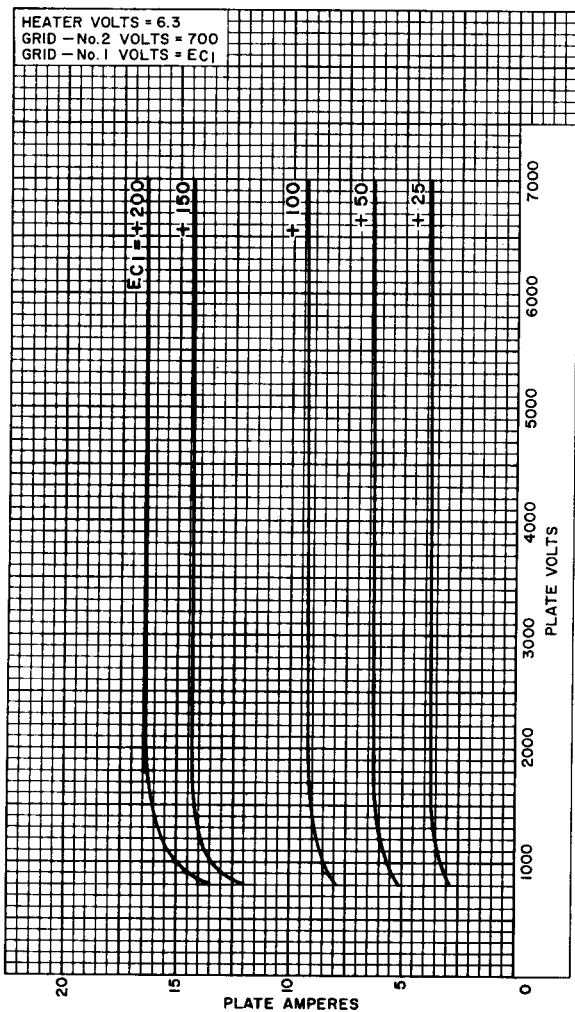

92CM-11883



TYPICAL PLATE CHARACTERISTICS

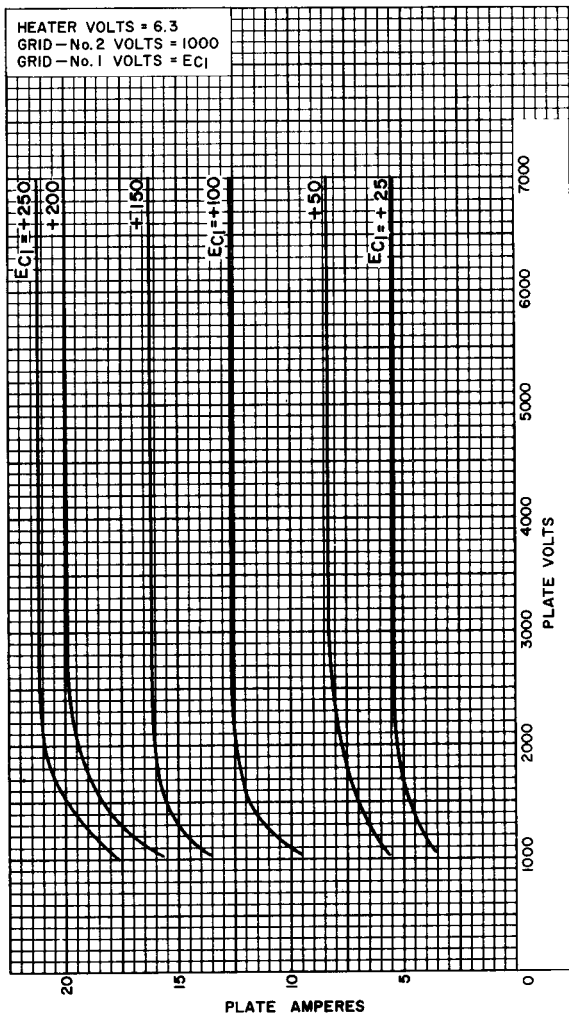

92CM-11889



TYPICAL CHARACTERISTICS

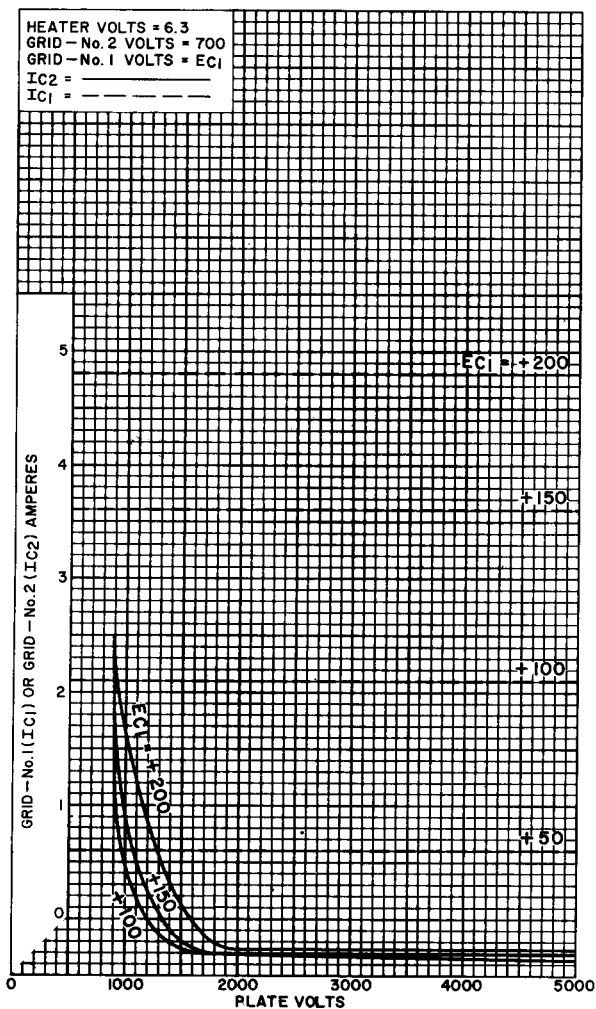

92CM-11884



TYPICAL CHARACTERISTICS

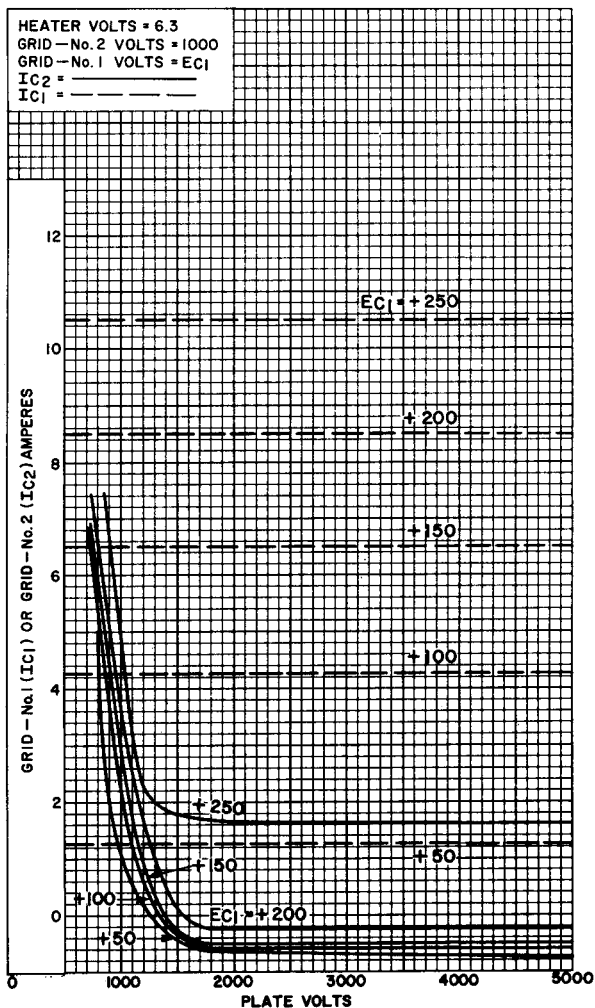

92CM-11891



TYPICAL CONSTANT-CURRENT CHARACTERISTICS

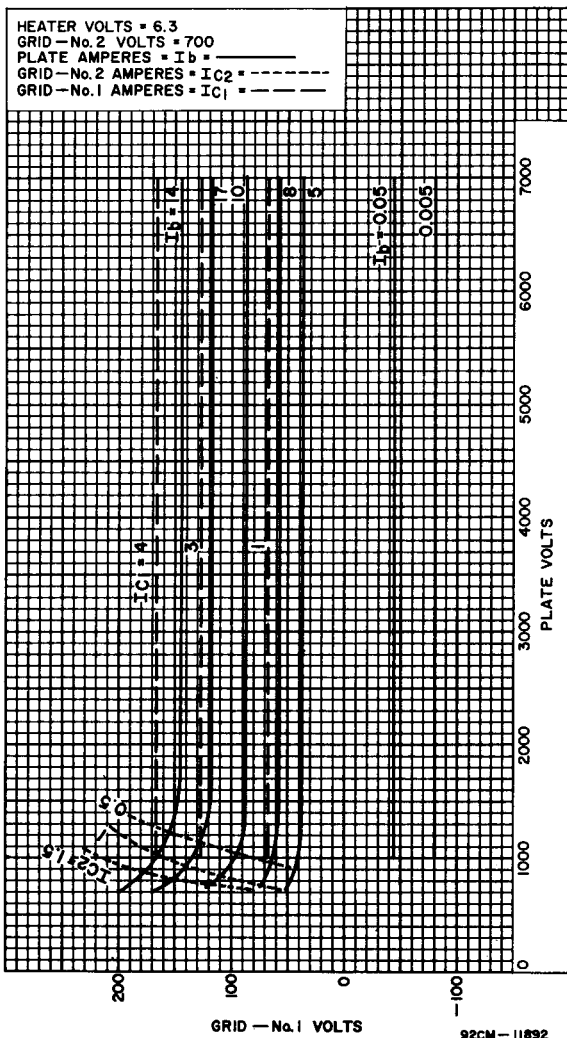

TYPICAL CONSTANT-CURRENT CHARACTERISTICS

