

DUAL 40 MSPS 6-BIT ANALOG TO DIGITAL CONVERTER

ADVANCE DATA

- RESOLUTION 6-BIT
- MAX. SAMPLING FREQUENCY : 40 MSPS
- TTL DATA OUTPUTS
- BUILT-IN SAMPLING AND HOLD CIRCUIT
- DUAL ADC ON CHIP TO IMPROVE CHANNEL MATCHING

APPLICATIONS

- QPSK DEMODULATION IN A SATELLITE DECODER

DESCRIPTION

The STV0190 is a dual 40 MSPS 6-bit Analog to Digital converter.

It is dedicated to QPSK demodulation in Satellite receiver.

The Flash architecture combined with interpolation technic gives the best trade off between power consumption and maximum conversion speed.

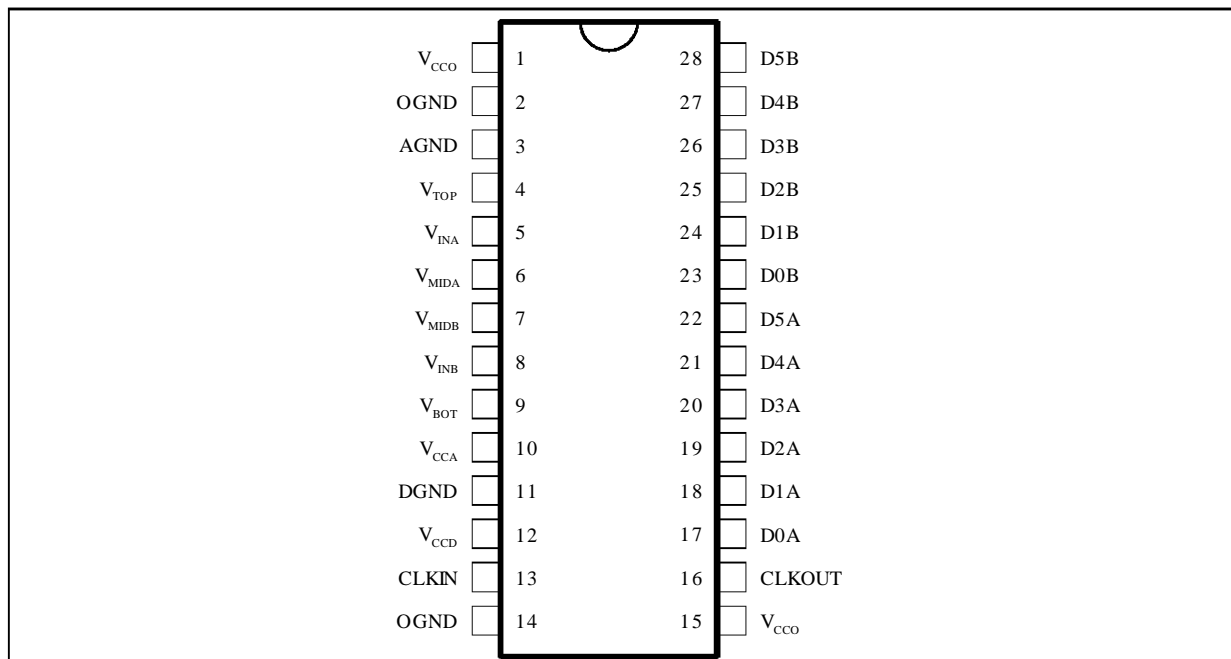
**PIN CONNECTIONS**

0190-01.EPS

PIN CONFIGURATION

Pin N°	Symbol	Function
1	V _{CCO}	Output Buffer Supply Voltage Channel A + B
2	OGND	Output Buffer Ground Channel A + B
3	AGND	Analog Ground
4	V _{TOP}	Top Reference Voltage
5	V _{INA}	Analog Input Channel A
6	V _{MIDA}	Reference Voltage DC Coupling Channel A
7	V _{MIDB}	Reference Voltage DC Coupling Channel B
8	V _{INB}	Analog Input Channel B
9	V _{BOT}	Bottom Reference Voltage
10	V _{CCA}	Analog Supply Voltage
11	DGND	Digital Ground
12	V _{CCD}	Digital Supply Voltage
13	CLKIN	Clock Input
14	OGND	Output Buffer Ground Channel A + B
15	V _{CCO}	Output Buffer Supply Voltage Channel A + B
16	CLKOUT	Clock Output
17 to 22	D0A to D5A	D0 (LSB) to D5 (MSB) Outputs Channel A
23 to 28	D0B to D5B	D0 (LSB) to D5 (MSB) Outputs Channel B

0190-01.TBL

BLOCK DIAGRAM

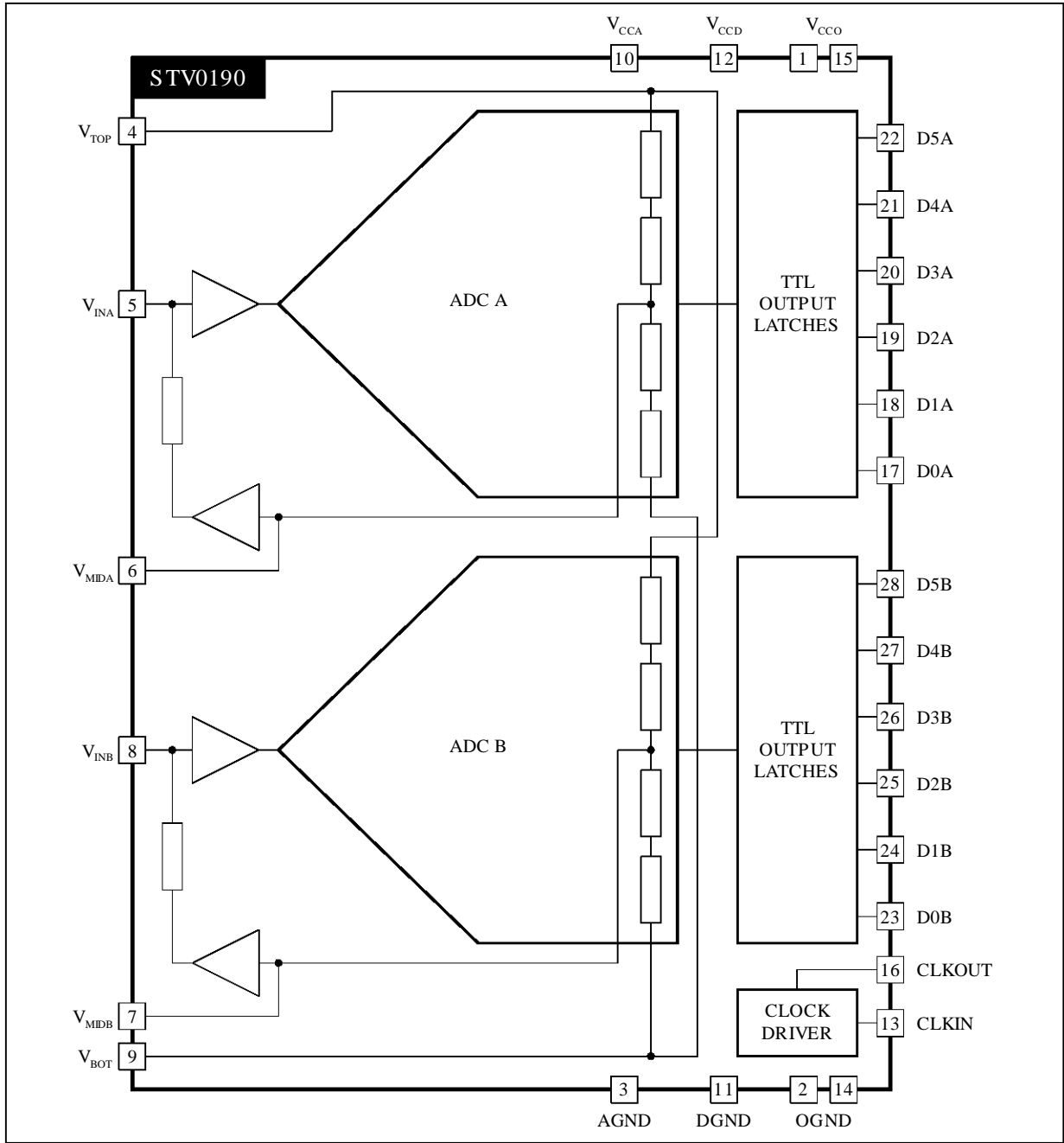

0190-02.EPS

ABSOLUTE MAXIMUM RATINGS

Symbol	Parameter	Value	Unit
	Analog Supply Voltage	3.1, 3.45	V
	Digital Supply Voltage	3.1, 3.45	V
T _{oper}	Operating Temperature	0, +70	°C

0190-02.TBL

ELECTRICAL CHARACTERISTICS (V_{CC} = 3.3V, T_{amb} = 0 to 70°C, Full scale 10MHz, 1.5V_{PP} input, 40MSPS, C_L = 20pF, unless otherwise specified)

Symbol	Parameter	Test Conditions	Min.	Typ.	Max.	Unit
--------	-----------	-----------------	------	------	------	------

ANALOG INPUT

	Differential Reference Voltage	V _{TOP} - V _{BOT}	1	1.5		V _{PP}
	Variation of Channel A to Channel B (FS)	0.5 LSB			8	mV
R _{IN}	Input Resistance		20			kΩ
	Input Bandwidth 3dB		20			MHz

DIGITAL OUTPUTS

	High Logic Voltage		2.4		V _{CC}	V																																												
	Low Logic Voltage		0		0.4	V																																												
	High Logic Current		-4			mA																																												
	Low Logic Current				4	mA																																												
	Logic Format		<table border="1"> <thead> <tr> <th colspan="2">Analog Input</th> <th colspan="2">Digital Output</th> </tr> </thead> <tbody> <tr> <td>most positive input</td> <td>63</td> <td>111111</td> <td></td> </tr> <tr> <td></td> <td>62</td> <td>111110</td> <td></td> </tr> <tr> <td></td> <td>....</td> <td>.....</td> <td></td> </tr> <tr> <td></td> <td>33</td> <td>100001</td> <td></td> </tr> <tr> <td></td> <td>32</td> <td>100000</td> <td></td> </tr> <tr> <td></td> <td>31</td> <td>011111</td> <td></td> </tr> <tr> <td></td> <td>30</td> <td>011110</td> <td></td> </tr> <tr> <td></td> <td>....</td> <td>.....</td> <td></td> </tr> <tr> <td></td> <td>1</td> <td>000001</td> <td></td> </tr> <tr> <td>least positive input</td> <td>0</td> <td>000000</td> <td></td> </tr> </tbody> </table>				Analog Input		Digital Output		most positive input	63	111111			62	111110					33	100001			32	100000			31	011111			30	011110					1	000001		least positive input	0	000000	
Analog Input		Digital Output																																																
most positive input	63	111111																																																
	62	111110																																																
																																																
	33	100001																																																
	32	100000																																																
	31	011111																																																
	30	011110																																																
																																																
	1	000001																																																
least positive input	0	000000																																																
t _{PD}	Output Timing	See Figure 1			9	ns																																												
t _v	Output Timing	See Figure 1	5			ns																																												
t _{SKEW}	Data Output Skew TSK (all outputs, settled within 20%)	See Figure 1			1	ns																																												
t _{APER}	Aperture Delay relative to Data Clock	See Figure 1			1	ns																																												
t _R , t _F	Data Output Rise and Fall Time				4	ns																																												

CLOCK INPUT

V _{IH}	High Input Voltage		2.0		V _{CC}	V
V _{IL}	Low Input Voltage		0		0.8	V
I _{IH}	High Input Current				TBD	μA
I _{IL}	Low Input Current		TBD			μA
	Clock Duty Cycle		40		60	%
t _{CL}	Clock Period	See Figure 1	24			ns

0190-03.TBL

ELECTRICAL CHARACTERISTICS (continued)

Symbol	Parameter	Test Conditions	Min.	Typ.	Max.	Unit
CLOCK OUTPUT						
V _{OH}	High Output Voltage		2.4		V _{CC}	V
V _{OL}	Low Output Voltage		0		0.4	V
I _{OH}	High Output Current		-4			mA
I _{OL}	Low Output Current				4	mA
	Clock Duty Cycle		40		60	%
t _{CL}	Clock Period		24			ns

REFERENCE LADDER

	Top Voltage				V _{CC} - 0.5	V
	Bottom Voltage		V _{CC} + 0.5			V
	DC Bias Restoration Error	Open input digital output should be	32/64 011111		33/64 100000	
ZV _{TOP} /V _{BOT}	Input Impedance		90			Ω

CROSSTALK

	Isolation A/B		37			dB
--	---------------	--	----	--	--	----

DC ACCURACY

	Integral non Lin.		-0.5		+0.5	LSB
	Diff. Non Lin.		-0.5		+0.5	LSB

AC ACCURACY (f_{IN} = 10MHz, FS = 40 MSPS, V_{IN} = 95% FSCALE)

	Effective Number of Bit		5			bits
SNR			33			dB
THD	THD First 5 Harmony		33			dB
	Integral non Lin.		-1		+1	LSB
	A/D Amplifier Response Mismatching				0.2	dB

0190-04.TBL

Figure 1 : Timing Diagram

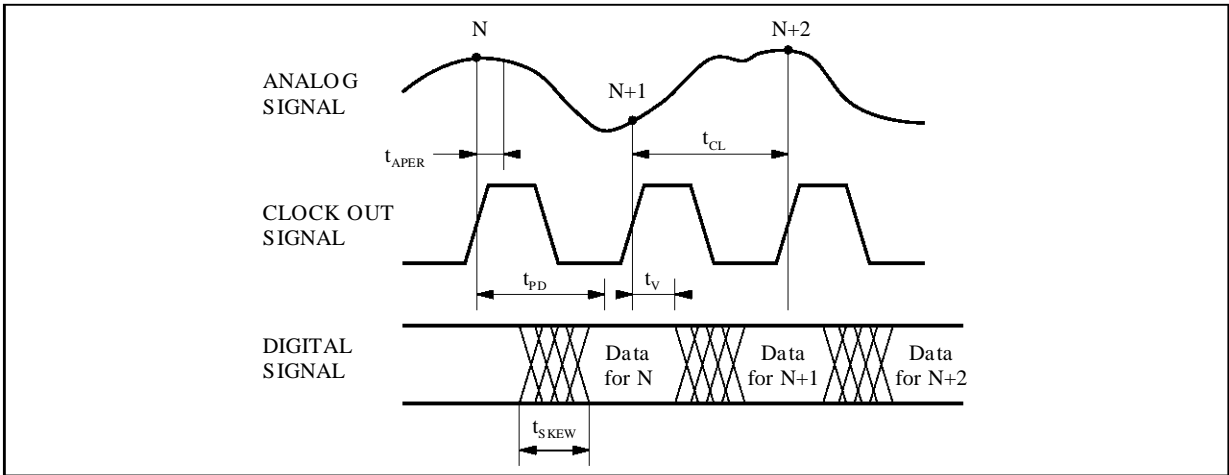

0190-03.EPS

Note : This diagram shows a delay of one clock cycle. Additional integer multiple delay periods are acceptable. Output data must be valid on the rising edge of the clock out signal.

TYPICAL APPLICATION

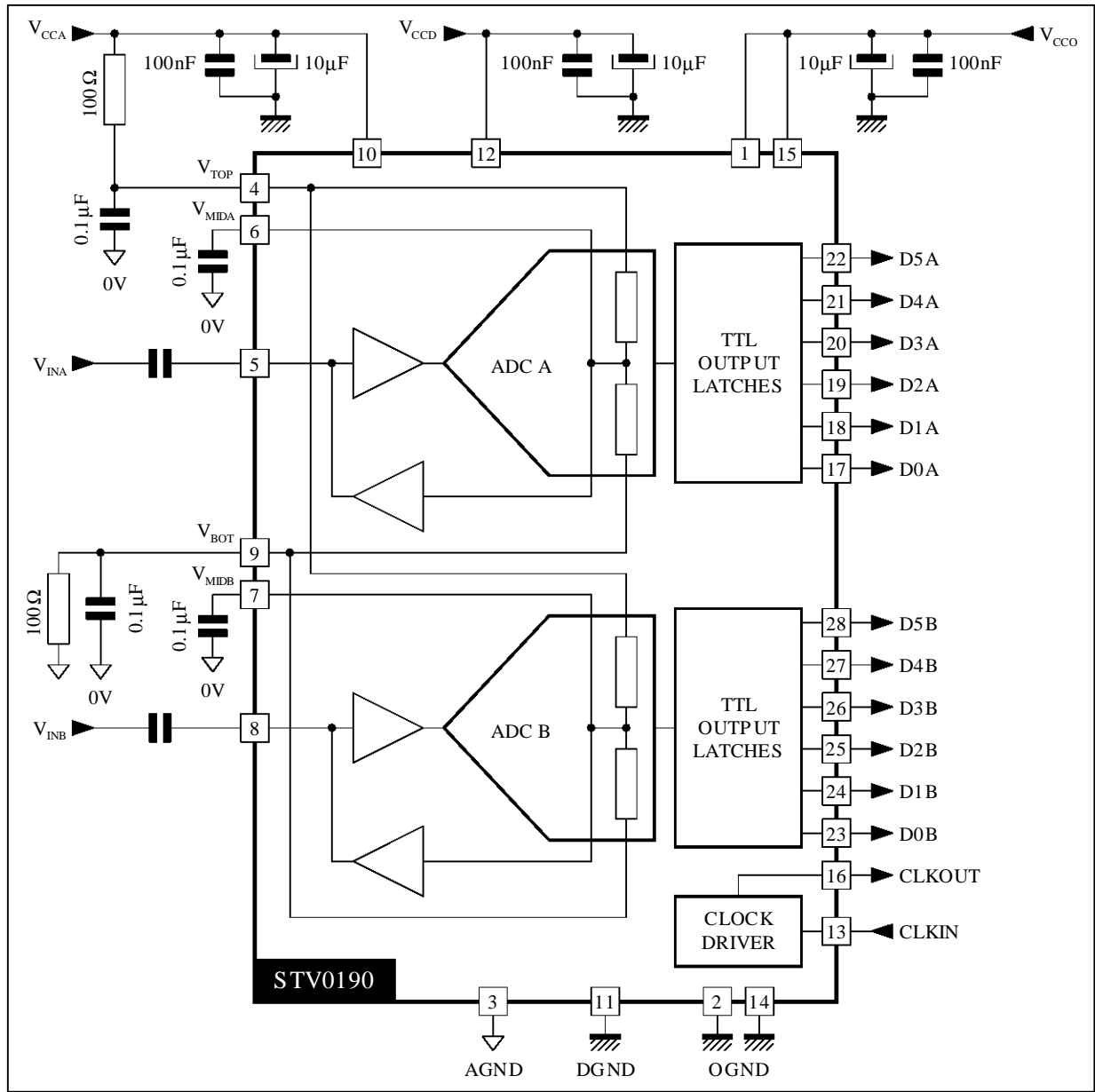

0190-04-EFS

PACKAGE MECHANICAL DATA
 28 PINS - PLASTIC MICROPACKAGE (SO)

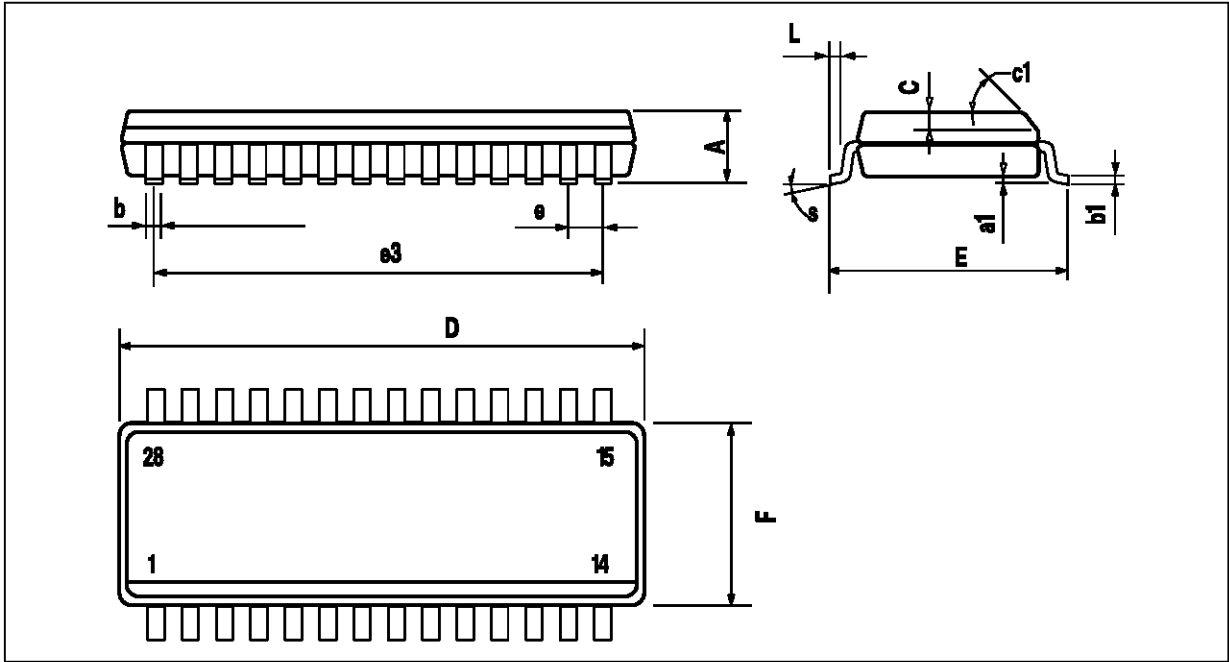

PM-SO28LEFS

Dimensions	Millimeters			Inches		
	Min.	Typ.	Max.	Min.	Typ.	Max.
A			2.65			0.104
a1	0.1		0.3	0.004		0.012
b	0.35		0.49	0.014		0.019
b1	0.23		0.32	0.009		0.013
C		0.5			0.020	
c1	45° (Typ.)					
D	17.7		18.1	0.697		0.713
E	10		10.65	0.394		0.419
e		1.27			0.050	
e3		16.51			0.65	
F	7.4		7.6	0.291		0.299
L	0.4		1.27	0.016		0.050
S	8° (Max.)					

SO28TBL

Information furnished is believed to be accurate and reliable. However, SGS-THOMSON Microelectronics assumes no responsibility for the consequences of use of such information nor for any infringement of patents or other rights of third parties which may result from its use. No licence is granted by implication or otherwise under any patent or patent rights of SGS-THOMSON Microelectronics. Specifications mentioned in this publication are subject to change without notice. This publication supersedes and replaces all information previously supplied. SGS-THOMSON Microelectronics products are not authorized for use as critical components in life support devices or systems without express written approval of SGS-THOMSON Microelectronics.

© 1996 SGS-THOMSON Microelectronics - All Rights Reserved

Purchase of I²C Components of SGS-THOMSON Microelectronics, conveys a license under the Philips I²C Patent. Rights to use these components in a I²C system, is granted provided that the system conforms to the I²C Standard Specifications as defined by Philips.

SGS-THOMSON Microelectronics GROUP OF COMPANIES

Australia - Brazil - Canada - China - France - Germany - Hong Kong - Italy - Japan - Korea - Malaysia - Malta - Morocco
 The Netherlands - Singapore - Spain - Sweden - Switzerland - Taiwan - Thailand - United Kingdom - U.S.A.