

Ordering number : EN4570

Thick Film Hybrid IC

SANYO	No. 4570	STK6215
	Unidirectional DC Motor Driver with Constant-Speed Digital Servo Controller (output current: 5 A)	

Overview

The STK6215 is a hybrid IC that combines in a single package a unidirectional DC motor driver, a PLL constant-speed controller (the LC7991) and associated peripheral components, including a separately excited oscillator, a comparator, and an FG amplifier. The motor controller uses a PLL circuit for precise motor control. The wide range of the STK6215's FG lock frequency allows it to handle a wide range of applications. Since the motor driver block uses MOSFET devices as power elements, it features high output currents (rush current) and low loss.

Applications

- Plain paper copier DC motor drivers
- FAX paper transport motor drivers
- Other DC motor applications

Features

<Motor Controller Block>

- High FG frequency upper limit (locking range: 200 to 2500 Hz)
- Built-in FG divider (FG lock upper limit with divider in use: 5000 Hz)
- Speed lock indicator output directly drives an external LED.
- TTL level compatible \overline{ROT} input

<Motor Driver Block>

- MOSFET power elements provide high output currents (rush current).
- Low loss PWM speed controller (built-in externally excited oscillator: 25 kHz)
- Wide power supply voltage range ($V_{DSS} = 60\text{ V}$)
- Built-in motor startup overcurrent limiter function

Package Dimensions

unit: mm

4138

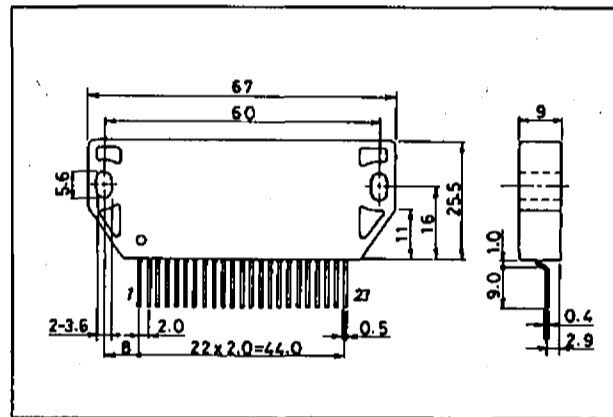

Specifications

Absolute Maximum Ratings at $T_a = 25^\circ\text{C}$

Parameter	Symbol	Condition	Rating	Unit
Maximum supply voltage 1	$V_{CC1\text{ max}}$	No signal	52	V
Maximum supply voltage 2	$V_{CC2\text{ max}}$	No signal	7	V
Maximum motor rush current	$I_O\text{ peak max}$	Duty 1%, period $\leq 100\text{ msec}$	12	A
Maximum input voltage	$V_{IH\text{ max}}$		7	V
Storage temperature	T_{stg}		-40 to +125	$^\circ\text{C}$
Junction temperature	$T_j\text{ max}$		150	$^\circ\text{C}$
Operating case temperature	$T_c\text{ max}$		105	$^\circ\text{C}$

SANYO Electric Co., Ltd. Semiconductor Business Headquarters

TOKYO OFFICE Tokyo Bldg., 1-10, 1 Chome, Ueno, Taito-ku, TOKYO, 110 JAPAN

83093YO 5-3096 No. 4570-1/11

STK6215

Allowable Operating Ranges at Ta = 25°C

Parameter	Symbol	Condition	Rating	Unit
Operating supply voltage 1	V _{CC1}	Input active	10 to 42	V
Operating supply voltage 2	V _{CC2}	Input active	5 ± 5%	V
Motor output current	I _O	DC (Tc = 25°C)	5	A
FET withstand voltage	V _{DSS}		60 min	V
Input voltage	V _{IH}		V _{CC2}	V

Operating Characteristics at Ta = 25°C, V_{CC1} = 24 V, V_{CC2} = 5.0 V

Parameter	Symbol	Condition	Rating			Unit
			min	typ	max	
V _{CC2} current dissipation	I _{CC}	When the ROT input is used		10	15	mA
Output FET saturation voltage	V _{SAT}	R _L = 4.5 Ω		0.85	1.2	V
Built-in oscillator frequency	f _O		21	25	31	kHz
OSC output amplitude	V _{OP-P}		1.9	2.3	2.7	V _{p-p}
OSC output effective amplitude	V _{ORMS}	Pin 7 output voltage	0.54	0.66	0.80	V _{rms}
Common mode input voltage range	V _{ICM}	Integrating amplifier and FG amplifier input voltage	0		V _{CC2} - 1.5	V
FG amplifier feedback resistance	R _F		95	100	105	kΩ
High input level voltage	V _{IH}	DIV1 to DIV3, PR1, PR2 and ROT inputs	0.7 V _{CC2}		V _{CC2}	V
Low input level voltage	V _{IL}		0		0.3 V _{CC2}	V
High input level current	I _{IH}	DIV1 to DIV3, PR1 and PR2 inputs			1	μA
Low input level current	I _{IL}		-1			μA
High output level current	I _{OIH}	Lock input V _{OH} = V _{CC2} - 0.4 V			-2	mA
Low output level current	I _{OIL}	Lock input V _{OL} = 0.4 V		2		mA
Input frequency range	f _{XI}	XI input	0.1		10.5	MHz
	f _{FG}	FGI input			50	kHz
FG lock frequency	f _{FLOCK}	FG Input divider off	200		2500	Hz
	f _{FLOCK}	FG Input divider on	400		5000	Hz
Output cut voltage	V _{OCUT}	Pin 5 input voltage	0		25	mV

Pin Functions

Pin No.	Symbol	Function
1	OUT	Motor output
2		
3	V _{rs}	Current detection resistor connection
4		
5	V _{ref4}	Motor startup current control reference voltage
6	V _{CC2}	Power supply voltage input (+5 V)
7	V _{ref1}	H/IC built-in oscillator bias voltage setting
8	V _{ref2}	Integrating amplifier reference voltage setting
9	V _{ref3}	FG input reference voltage setting
10	FG	FG input
11	R _F	Integrating amplifier output
12	Mix in	Integrating amplifier input
13	Mix out	PO and FO sum output (PO and FO each have a 100 kΩ output resistance.)
14	XI	Crystal oscillator connection (input)
15	XO	Crystal oscillator connection (output)
16	DIV1	Variable divider setting
17	DIV2	
18	DIV3	
19	PR1	Phase comparison range select
20	PR2	
21	ROT	Motor rotate/stop input; H: stop, L: rotate
22	Lock	Lock output; Outputs a low level when locked
23	SG	Ground

STK6215

I/O Formats

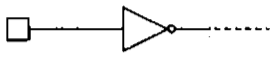
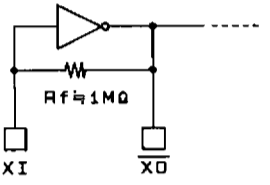
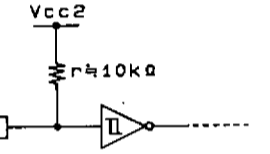
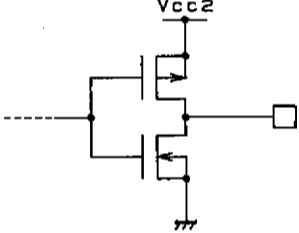
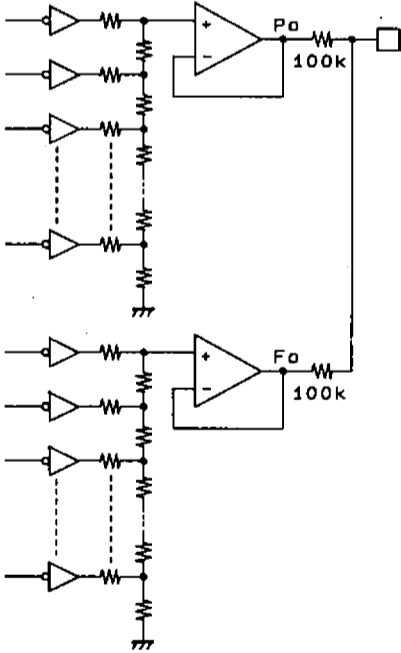
Pin No.	Format
16, 17, 18, 19	
14, 15	
21	
22	
13	 <p style="text-align: right;">Unit (resistance: Ω)</p>

STK6215

Equivalent Circuit

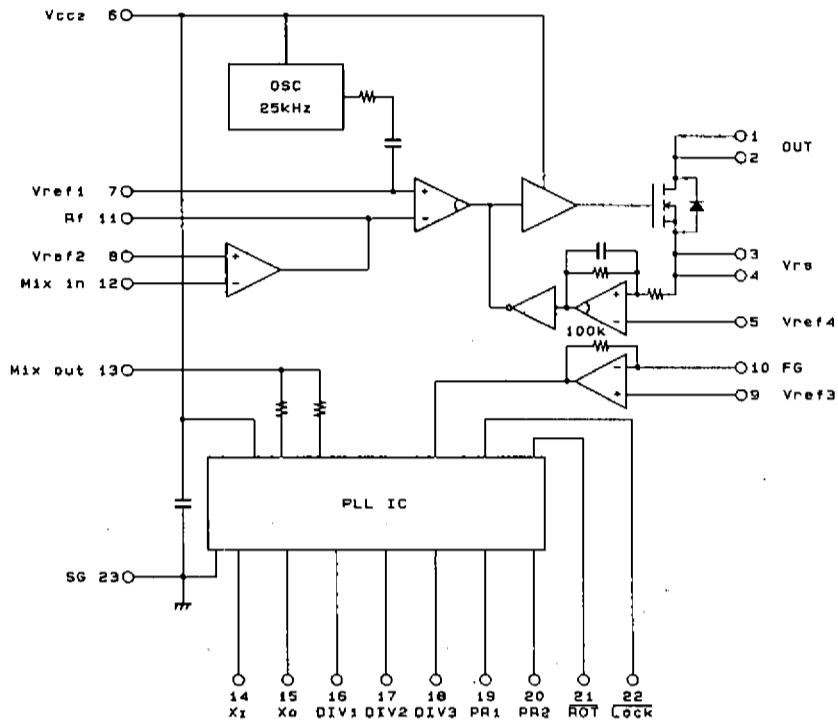

Unit (resistance: Ω)

Application Circuit Example

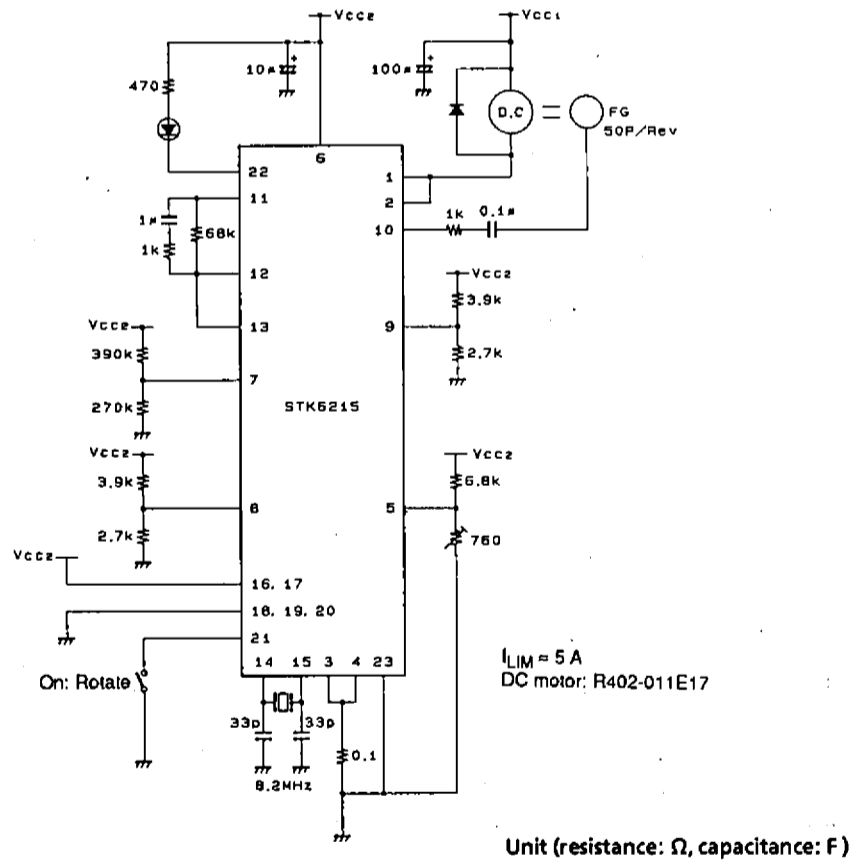

Unit (resistance: Ω, capacitance: F)

The circuit shown above locks at an FG frequency of 2000 Hz.
 Reference frequency: 8.2 MHz
 Variable divider: 1/2
 FG divider: Off

Operating Principles

1. Overview

Figure 1 shows the block diagram for the STK6215. The PLL control block compares the frequencies and phases of the FG signal frequency fed back from the motor with a reference clock, which is formed by dividing a reference signal. When they agree, the frequency is locked with a 50% duty. The control signals consist of two systems with D/A converted outputs: FO, which is the frequency control output and PO, which is the phase control output. Since PLL control provides a motor speed that is synchronized with a reference clock frequency f_{ref} , which is created by dividing a reference signal, the stability of f_{ref} directly influences the stability of the rotation. Therefore, quartz precision digital control is possible by using a crystal oscillator for reference signal generation. The control signals are added by an integration circuit, which also functions as an active filter. It is here that the servo system gain and phase compensation are performed. The output of this system is sent to the PWM conversion block and a PWM signal, which is based on the period of an associated oscillator circuit, is input to the unidirectional driver of the final stage, which drives the DC motor.

2. Motor Speed, Resonant Frequency, and Encoder Pulse Count

The frequency f_{FG} of the signal generated by the encoder is given by:

$$f_{FG} \text{ (Hz)} = \frac{N \text{ (rpm)}}{60} \times P \text{ (P/R)} \dots\dots\dots ①$$

Where, N: Motor speed (rpm)
 P: Number of pulses per encoder rotation

Formula ① can be transformed as follows:

$$N \text{ (rpm)} = \frac{60 \times f_{FG}}{P \text{ (P/R)}} \dots\dots\dots ②$$

Alternatively,

$$P \text{ (P/R)} = \frac{60 \times f_{FG}}{N} \dots\dots\dots ③$$

Here, the relationship with the oscillator resonant frequency is given by:

$$N \text{ (rpm)} = \frac{60}{P} \times \frac{f_{xtal}}{DIV \times 2050 \text{ (1025)}} \dots\dots\dots ④$$

Alternatively,

$$P \text{ (P/R)} = \frac{60}{N} \times \frac{f_{xtal}}{DIV \times 2050 \text{ (1025)}} \dots\dots\dots ⑤$$

Here, DIV: Variable divider ratio
 See item 3-1, subsection (3).
 The value (1025) is used when the f_{FG} input frequency is divided by 2 (as determined by DIV setting).
 See item 3-1, subsection (3).

Note that the following three methods for increasing the stability of the motor speed can be considered.

- ① Increasing the number of encoder output pulses for a given motor speed.
- ② Not using the FG divider if at all possible, since using it decreases the precision of the rotation data.
- ③ Setting the divider ratio to as low a value as possible, so that the oscillator precision is not reduced.

STK6215

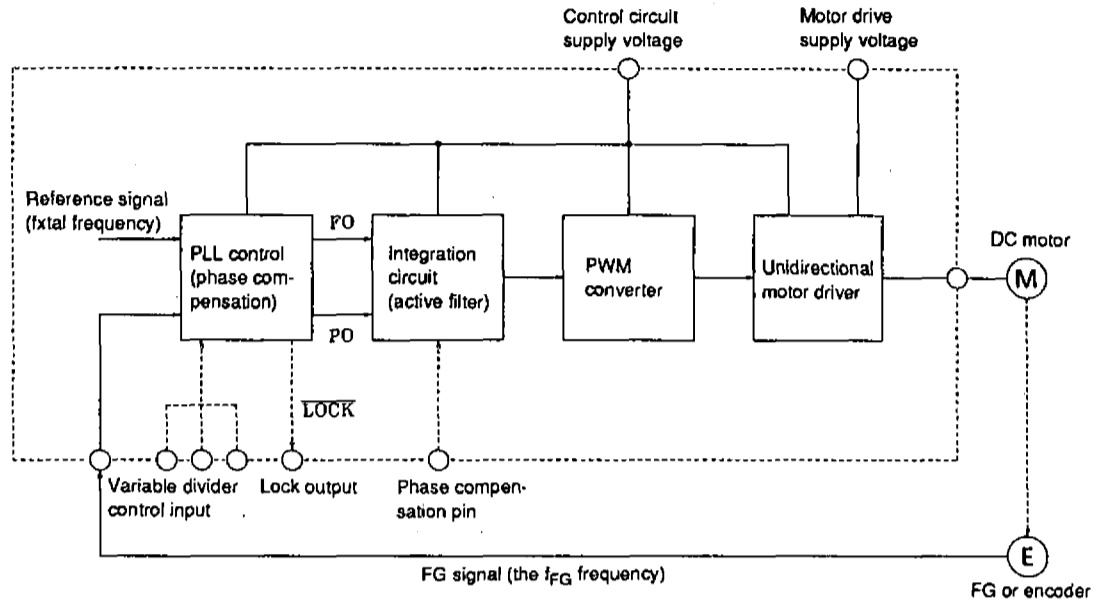

Figure 1 STK6215 Block Diagram

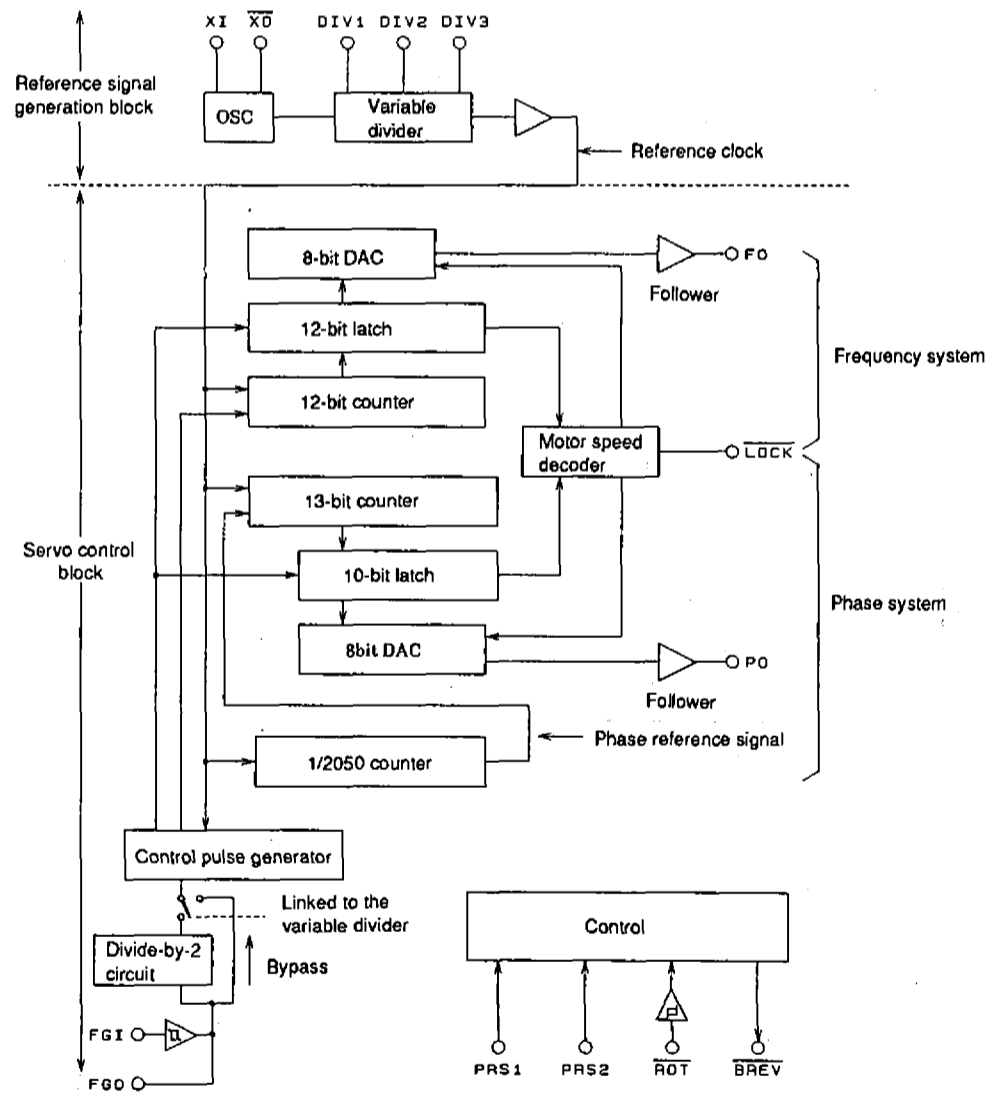

Figure 2 PLL IC Block Diagram

3. Block Functional Descriptions

3-1 Reference Signal Generation Block

(1) Crystal oscillator circuit

The controller block generates a reference clock using a crystal oscillator and a capacitor connected to the XI and X̄O pins. It is also possible to leave the X̄O pin open and input an external clock to the XI pin.

(2) Crystal resonant frequency calculation

Reference oscillator circuit

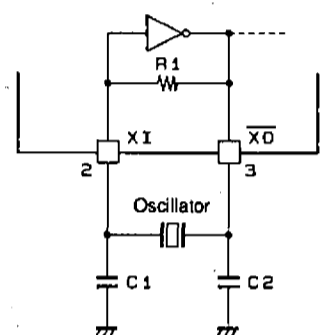

External clock input

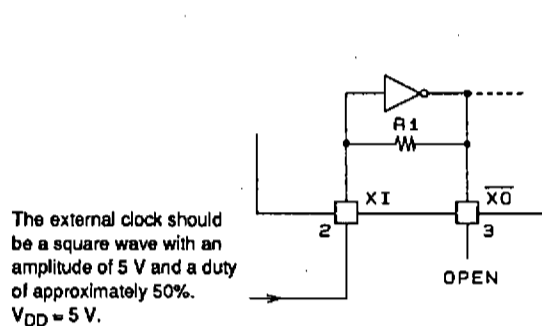

After determining the FG frequency to be locked, use the following formula to derive the required crystal frequency.

- a) With the FG divider off
 $f_{xtal} = f_{FGLock} \times DIV \times 2050 \text{ (Hz)}$
- b) With the FG divider on
 $f_{xtal} = f_{FGLock} \times DIV \times 1025 \text{ (Hz)}$

Where:

- f_{xtal}: Crystal resonant frequency
- f_{FGLock}: The FG frequency to be locked
- DIV: The variable divider ratio

(3) Variable divider and the FG divider

The controller block includes a 6-setting variable divider and an FG divider (divide-by-2, by-passable) to expand the range of input FG frequencies. These dividers are controlled by the three pins DIV1, DIV2 and DIV3 as shown in table 1.

Table 1 Divider Control

Control input			Variable divider ratio	FG divider
DIV3	DIV2	DIV1		
High level	High level	High level	20	OFF
High level	High level	Low level	10	OFF
High level	Low level	High level	6	OFF
High level	Low level	Low level	3	OFF
Low level	High level	High level	2	OFF
Low level	High level	Low level	1	OFF
Low level	Low level	High level	2	ON
Low level	Low level	Low level	1	ON

3-2 Servo Control Block

The servo block compares the reference clock generated by the reference signal generation block with the FGI input (the FG signal input from the motor) and generates three output signals: FO (frequency system control output), PO (phase system control output) and Lock (the lock indicator output). The FO and PO outputs are 8-bit D/A converter outputs. The motor drive signal is created from these two outputs. The Lock output indicates whether the motor is within the lock range.

(1) Servo Operation

Control system operation is divided into the following three aspects depending on the input FG frequency: drive, tracking (locked), and brake.

FG input frequency	Operation	Lock output	FO output	PO output
$> f_{FGLock} + 6\%$ Overspeed	Brake	High level	Low level	Low level
$f_{FGLock} \pm 6\%$ Lock range	Tracking	Low level	DA output (frequency-voltage conversion)	DA output (phase-voltage conversion)
$< f_{FGLock} - 6\%$ Underspeed	Drive	High level	High level	High level

Notes

$$f_{FGLock} = \frac{f_{xtal}}{DIV \times 2050 (1025)} \text{ (Hz)}$$

Caution: The value in parentheses is used when the FG divider is on.
 f_{FGLock} : FG frequency when locked; f_{xtal} : Crystal resonant frequency; DIV: Variable divider ratio

- The drive operation is performed at startup (under speed) time.
- When the FO and PO outputs are set to the high level, the motor is driven at full speed.
- Braking operation is performed when the motor is in over speed range.
- When the FO and PO outputs are set to the low level, the motor brake is applied.
- The servo control block controls the motor by using these two operations to pull the motor speed into the lock range. (Note that the operations described up to this point are the rough adjustments performed by the frequency system.)

(2) FO and PO outputs (frequency system control output and phase system control output)

When the FG input frequency enters the lock range, the servo control switches to tracking operation. Frequency system fine control and phase system control starts, and the FO and PO outputs are switched to voltage outputs from internal D/A converters. Since the internal D/A converters are 8-bit converters, these output voltages have 256 possible levels. The figures below show the FO and PO output characteristics.

● FO Output Characteristics

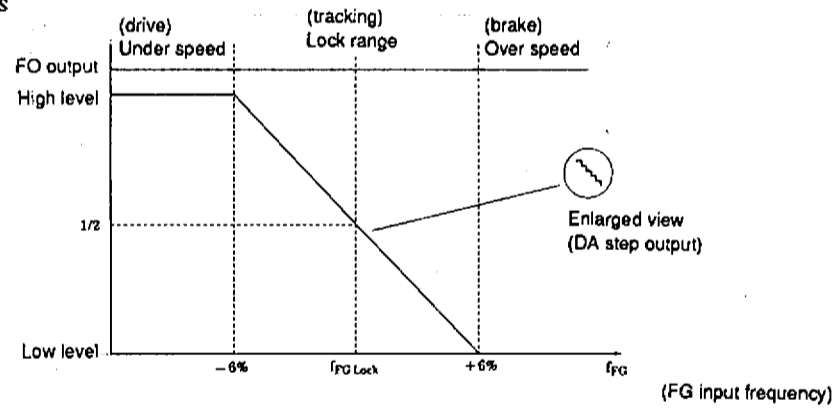

● PO Output Characteristics (during tracking)

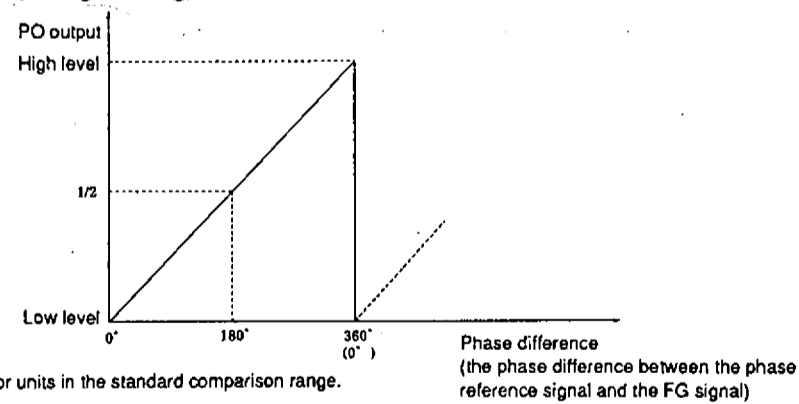

Caution: These characteristics are for units in the standard comparison range.

3-3 Accessory Functions

(1) \overline{ROT} input (rotate/stop)

The \overline{ROT} input turns the motor on or off.

ROT input	State	FO output	PO output
High level	Stop	Low level	Low level
Low level	Operate	*	*

*: Determined by the motor control function.

(2) PRS1 and PRS2 inputs (phase comparison range selection)

The phase system comparison range can be switched using the PRS1 and PRS2 inputs.

Phase System Comparison Range Selection

PRS2 input	PRS1 input	Range name	Comparison range	Phase output frequency
Low level	Low level	Standard range	2π	Once every FG input
Low level	High level	Test mode
High level	Low level	Double range	6π	Once every two FG inputs
High level	High level	Quadruple range	14π	Once every four FG inputs

Caution: The phase range becomes more than two and four times the normal range due to the operation of a built-in limiter. These phase output frequency values are divided by two when the FG divider is used.

● Phase Output Characteristics

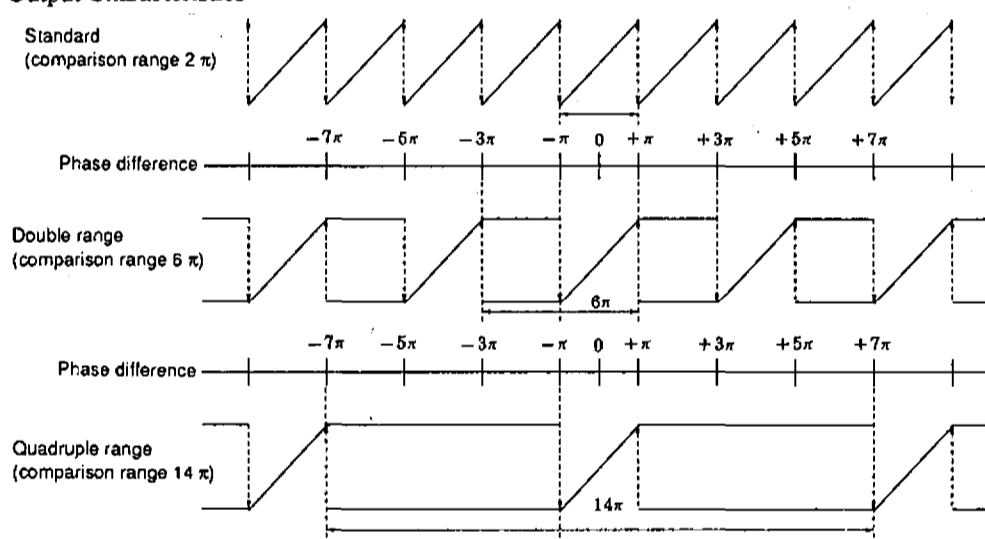

Caution: The "phase difference" is the phase difference in the FG signal input with respect to the internal reference signal. The double and quadruple ranges have hysteresis.

● FG Clock Frequencies (examples)

Variable divider ratio	FG divider	Oscillator resonant frequency (MHz)					Unit
		2.05	4.1	6.15	8.2	10.25	
20	OFF	50	100	150	200	250	Hz
10		100	200	300	400	500	Hz
6		116	333	500	667	833	Hz
3		333	667	1000	1333	1667	Hz
2		500	1000	1500	2000	2500	Hz
	ON	1000	2000	3000	4000	5000	Hz

The following two ceramic oscillators, which are available as commercial products, can be used.

CSA6.14MT (Murata) ... Handles FG frequencies of 500, 1000 and 1500 Hz.

CSA8.20MT (Murata) ... Handles an FG frequency of 2000 Hz.

4. Rush Current Limiter Circuit

4-1 Circuit Purpose

The STK6215 provides a function that can limit the current when the motor starts (or brakes). This function allows the external current (peak) output capacity to be reduced. The rush current limit value can be changed arbitrarily by adjusting the value of an external resistor.

4-2 Setting the Limit Value

Figure 3 shows the method for setting the limit value. The Vref voltage is adjusted by changing the value of RO2. Formula 6 is the formula for the limit value, I_{LIM}.

$$I_{LIM} (A) = \underbrace{\frac{RO2}{RO1 + RO2}}_{V_{ref}} \times V_{CC2} \times \frac{1}{R_s} \dots\dots\dots ⑥$$

- RO1: 6.8 kΩ (fixed)
- RO2: Variable
- V_{CC2}: 5 V
- R_s: Current detection resistance (Ω)

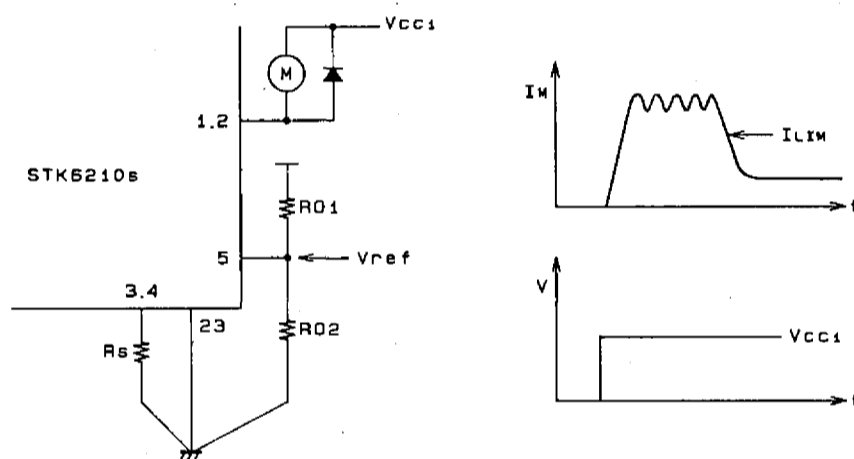

Figure 3 External Peripheral Circuit and Motor Startup Timing Chart

- Caution:**
- Here, the Vref voltage must be set in a range that fulfills the following condition.
 $V_{ref} \geq 0.025 \text{ V}$ (However, $V_{CC2} = 5 \text{ V} \pm 5\%$ is the alteration condition.)
 The limiter function will not operate if the above condition is not met.
 - Although formula ⑥ can be used as a rough formula for setting the output current, the actual value will differ due to the influence of voltage drops due to the ground pattern design external to the hybrid IC. Therefore we recommend that I_{LIM} final confirmation be performed in a circuit that has a form close to that of the PCB final pattern.

4-3 Value of the Current Detection Resistor (Rs)

R_s detects current flowing from the motor, and the voltage drop across R_s is sensed by an internal comparator. When an external R_s is connected to the STK6215, a resistor with a value that fulfills the following condition must be used.

$$R_s \times I_{LIM} \leq 0.5 \text{ V} \dots\dots\dots ⑦$$

Also, the PCB pattern should be designed so that R_s, RO2 and the STK6215's ground pin (pin 23) are connected to a single ground point as close as possible to the STK6215 in the pattern. In particular, R_s and the STK6215's pins 3 and 4 must not be located any significant distance from the IC.

STK6215

5. MOSFET Drain-Source Overvoltage

When using the STK6215, a diode is connected in parallel with the DC motor as a regenerative diode for the motor. This also functions as a protective measure against excessive MOSFET flyback voltage. Flyback voltage is due to the influence of circuit factors such as lead inductances, and will remain when the MOSFET turns off. (In general, these voltages are a few volts for periods of up to 0.5 μ s.) Therefore, as a final circuit operation check, confirm that the flyback voltage does not exceed V_{OSS} .

6. Thermal Design

Applications must be designed so that the temperature of the STK6215's aluminum substrate side never exceeds 105°C in any situation. The remainder of this section discusses thermal design for the STK6215.

6-1 Hybrid IC Average Internal Loss Derivation

The main component of the average internal loss occurs in the MOSFET, which is the PWM element.

The MOSFET loss is expressed as follows:

$$P_d (W) = V_{SAT} \times I_M \times f_p \times t_{ON} \dots \dots \dots \textcircled{8}$$

- V_{SAT} : FET saturation voltage
- I_M : Motor output peak current
- t_{ON} : FET on time
- f_p : IC internal oscillator frequency

6-2 Deriving the heat sink size

Formula $\textcircled{9}$ shows the thermal resistance of the required heat sink.

$$\theta_{c-a} (\text{°C/W}) = \frac{T_c \text{ max} - T_a}{P_d} \dots \dots \dots \textcircled{9}$$

A heat sink that is appropriate for θ_{c-a} must be selected. (Note that θ_{c-a} for the STK6215 is 18.5°C/W.)

■ No products described or contained herein are intended for use in surgical implants, life-support systems, aerospace equipment, nuclear power control systems, vehicles, disaster/crime-prevention equipment and the like, the failure of which may directly or indirectly cause injury, death or property loss.

■ Anyone purchasing any products described or contained herein for an above-mentioned use shall:

- ① Accept full responsibility and indemnify and defend SANYO ELECTRIC CO., LTD., its affiliates, subsidiaries and distributors and all their officers and employees, jointly and severally, against any and all claims and litigation and all damages, cost and expenses associated with such use:
- ② Not impose any responsibility for any fault or negligence which may be cited in any such claim or litigation on SANYO ELECTRIC CO., LTD., its affiliates, subsidiaries and distributors or any of their officers and employees jointly or severally.

■ Information (including circuit diagrams and circuit parameters) herein is for example only; it is not guaranteed for volume production. SANYO believes information herein is accurate and reliable, but no guarantees are made or implied regarding its use or any infringements of intellectual property rights or other rights of third parties.