

# SP8000 SERIES

## HIGH SPEED DIVIDERS

**SP8616 B&M** 1 GHz ÷ 4    **SP8615 B&M** 900MHz ÷ 4  
**SP8614 B&M** 800MHz ÷ 4    **SP8613 B&M** 700MHz ÷ 4

The SP8616 series of UHF counters are fixed ratio ÷ 4 asynchronous emitter coupled logic counters with, in the case of the SP8616B, a maximum operating frequency in excess of 1GHz, over a temperature range of 0°C to +70°C. The input is normally capacitively coupled to the signal source but can be DC coupled if it is required. The two complementary emitter follower outputs are capable of driving 100Ω lines and interfacing to ECL with the same positive supply. The SP8616 series require supplies of 0V and -7.4V (± 0.4V).

### FEATURES

- DC to 1GHz operation.
- 0°C to 70°C operation guaranteed at maximum specified frequency and over a wide dynamic input range.
- Complementary emitter follower O/Ps, ECL compatible.

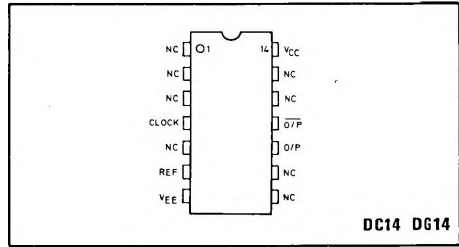

Fig. 1 Pin connections

### APPLICATIONS

- UHF Instrumentation, Including Counters and Timers
- Prescaling for UHF Synthesisers.

### ABSOLUTE MAXIMUM RATINGS

Power supply voltage	$V_{CC} - V_{EE}$	10 volts
Input voltage	$V_{INac}$	2.5 volts p-p
Output current		15mA
Storage temperature range		-55°C to +150°C
Maximum operating function temperature		+150°C

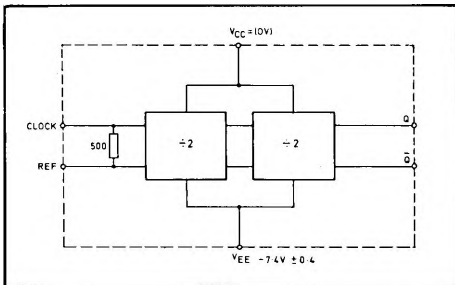

Fig. 2 Functional diagram

### QUICK REFERENCE DATA

- $V_{CC} = 0V$
- $V_{EE} = -7.4V \pm 0.4V$
- Input Voltage Range 400mV to 1.2V (see Fig. 3)
- Output Voltage Swing 700mV Typ.
- Temp. Range: 'B' Grade 0°C to +75°C  
'M' Grade -40°C to +85°C

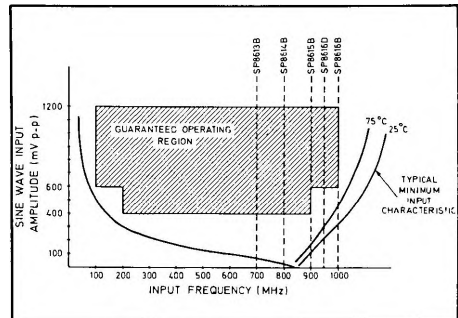

Fig. 3 Specified range of operation

ELECTRICAL CHARACTERISTICS

Test conditions (unless otherwise stated).

- $T_{amb}$  = 'B' grade: 0°C to +70°C; 'M' grade: -40°C to +85°C
- Supply voltage
- $V_{CC} = 0V$
- $V_{EE} = -7.4V \pm 0.4V$

Characteristic	Type	Value			Units	Conditions
		Min.	Typ.	Max.		
Max.toggle frequency	SP8616	1000			MHz	$V_{IN} = 600mV$ to 1.2Vp-p (see Fig. 3)
	SP8615	900			MHz	$V_{IN} = 400MHz$ to 1.2V p-p
	SP8614	800			MHz	$V_{IN} = 400MHz$ to 1.2V p-p
	SP8613	700			MHz	$V_{IN} = 400MHz$ to 1.2V p-p
Min.toggle frequency for correct operation with sine wave input	ALL			200	MHz	$V_{IN} = 400mV$ to 1.2V p-p
Min.toggle frequency for correct operation with sine wave input	ALL			100	MHz	$V_{IN} = 600mV$ to 1.2V p-p
Min slew rate for square wave input to guarantee operation to 0Hz	ALL			200	V/ $\mu s$	
Output voltage swing	ALL	500	700		mV	
Power supply drain current	ALL		45	60	mA	$V_{EE} = -7.4V$

Toggle Frequency Test Board Layout

1. All connections to the device are kept short.
2. The capacitors are leadless ceramic types.
3. In practice, the device is tested in an Augat .14 lead DIL socket which degrades the performance slightly. If the device is mounted in a low profile socket or soldered into a printed circuit board, the specified performance will be exceeded.

OPERATING AND APPLICATION NOTE

The SP8616 series of dividers are very simple to use but normal high frequency rules should be followed for optimum performance, for example, all connections should be kept short, the capacitors and resistors should be types suitable for the frequencies involved, etc.

The input is normally capacitively coupled to the signal source. There is an internal 500Ω resistor connecting the input to a reference voltage; this biases the input in the middle of the transfer characteristic. The reference voltage is brought out onto pin 6, which should be decoupled to the earth plane.

The sensitivity of the device can be increased by DC coupling the input signal about earth (see Fig. 5).

$V_{CC} - V_{EE}$  should be kept inside the specified 7.4 volts  $\pm$  0.4 volts but the actual value of  $V_{CC}$  relative to earth is not very critical and can be varied between 4.0V and 6.0V with only a small effect on performance. A  $V_{CC}$  of about 5.2V is the optimum for full temperature range operation.

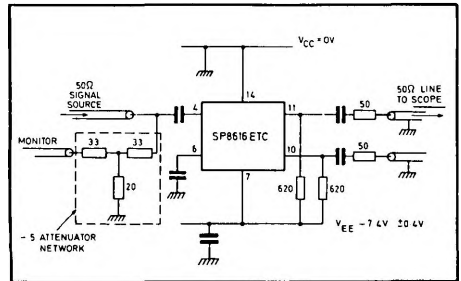

Fig. 4 Toggle frequency test circuit

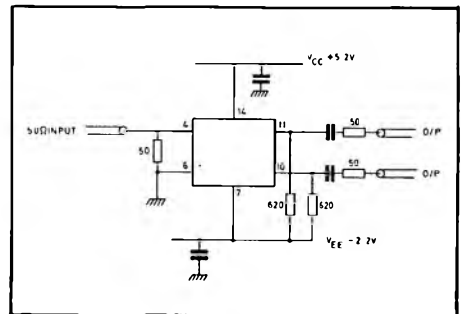

Fig. 5 Circuit for using the input signal about earth potential

In the absence of an input signal both the DC coupled and the capacitively coupled circuits will self oscillate with an output frequency of approximately 200MHz. This can be prevented by connecting a 10kΩ resistor between the input and the negative rail. This offsets the input sufficiently to stop the oscillation but it also reduces the input sensitivity by approximately 100mV.

The SP8616 will miscount with low frequency sinewave inputs or slow ramps. A slew rate of 200V/μs or greater is necessary for safe operation at low frequencies.

The output can be interfaced to ECL II directly and to ECL III using two resistors. (See Fig. 6).

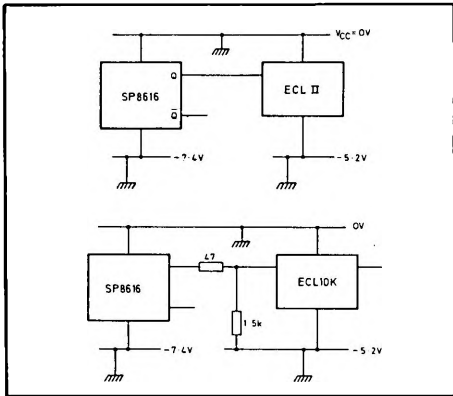

Fig. 6 Interfacing SP8616 series to ECL II and ECL III

The input impedance of the SP8616 is a function of frequency and minimises at about the same frequency as the maximum input sensitivity, so, although it can load the signal source significantly there is usually enough signal to operate the device satisfactorily when the input impedance is at a minimum input signal requirement. The worst case occurs at the maximum frequency because this is where the input sensitivity is worst.

A commercially available hybrid amplifier can be used to drive the SP8616 (see Fig. 7).

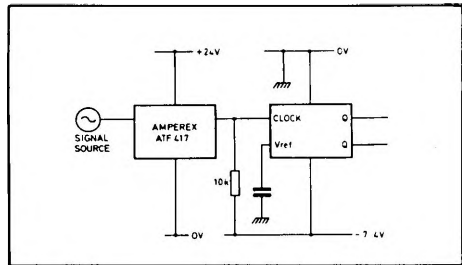

Fig. 7 The SP8616 driven by a commercially available hybrid amplifier. The Amperex ATF417 output is internally capacitively coupled.

Note: The Amperex ATF 417 output is internally capacitively coupled.

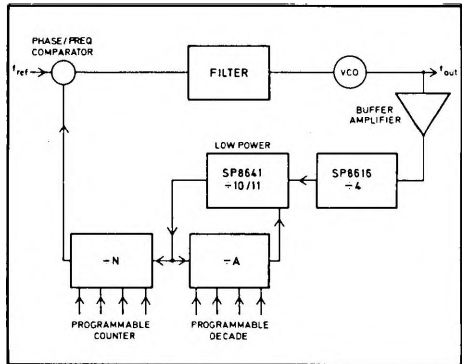

Fig. 8 A 1GHz synthesiser loop

The SP8616 series can be used in instrumentation for direct counting applications up to 1GHz and in frequency synthesisers.

In a frequency synthesiser, the SP8616 and the SP8641 can be used together (see Fig. 8).