

SN74LVTH16646-EP

3.3-V ABT 16-BIT BUS TRANSCEIVER WITH 3-STATE OUTPUTS

SCBS786A – NOVEMBER 2003 – REVISED APRIL 2004

- **Controlled Baseline**
 - One Assembly/Test Site, One Fabrication Site
- **Enhanced Diminishing Manufacturing Sources (DMS) Support**
- **Enhanced Product-Change Notification**
- **Qualification Pedigree†**
- **Member of the Texas Instruments Widebus™ Family**
- **State-of-the-Art Advanced BiCMOS Technology (ABT) Design for 3.3-V Operation and Low Static-Power Dissipation**
- **Supports Mixed-Mode Signal Operation (5-V Input and Output Voltages With 3.3-V V_{CC})**
- **Supports Unregulated Battery Operation Down To 2.7 V**
- **Typical V_{OLP} (Output Ground Bounce) <0.8 V at $V_{CC} = 3.3$ V, $T_A = 25^\circ\text{C}$**
- **I_{off} and Power-Up 3-State Support Hot Insertion**
- **Bus Hold on Data Inputs Eliminates the Need for External Pullup/Pulldown Resistors**
- **Distributed V_{CC} and GND Pins Minimize High-Speed Switching Noise**
- **Flowthrough Architecture Optimizes PCB Layout**
- **Latch-Up Performance Exceeds 500 mA Per JESD 17**
- **ESD Protection Exceeds 2000 V Per MIL-STD-883, Method 3015; Exceeds 200 V Using Machine Model ($C = 200$ pF, $R = 0$)**
- **Thin Shrink Small-Outline (DGG) Package**

DGG PACKAGE
(TOP VIEW)

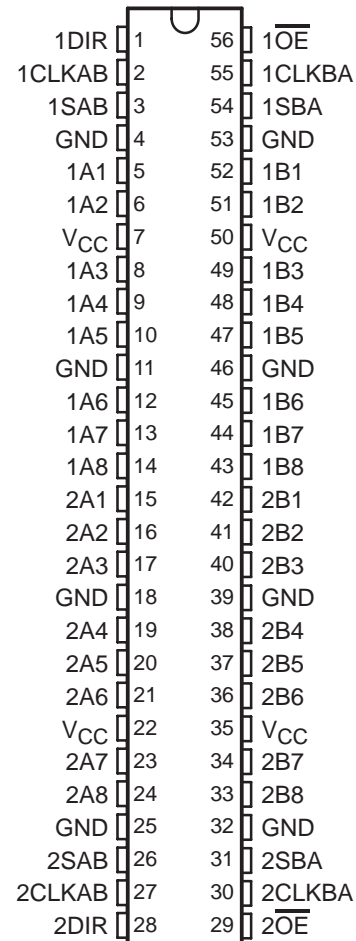

† Component qualification in accordance with JEDEC and industry standards to ensure reliable operation over an extended temperature range. This includes, but is not limited to, Highly Accelerated Stress Test (HAST) or biased 85/85, temperature cycle, autoclave or unbiased HAST, electromigration, bond intermetallic life, and mold compound life. Such qualification testing should not be viewed as justifying use of this component beyond specified performance and environmental limits.

description/ordering information

The SN74LVTH16646 is a 16-bit bus transceiver designed for low-voltage (3.3-V) V_{CC} operation, but with the capability to provide a TTL interface to a 5-V system environment.

This device can be used as two 8-bit transceivers or one 16-bit transceiver. Data on the A or B bus is clocked into the registers on the low-to-high transition of the appropriate clock (CLKAB or CLKBA) input. Figure 1 illustrates the four fundamental bus-management functions that can be performed with the SN74LVTH16646 device.



Please be aware that an important notice concerning availability, standard warranty, and use in critical applications of Texas Instruments semiconductor products and disclaimers thereto appears at the end of this data sheet.

Widebus is a trademark of Texas Instruments.

PRODUCTION DATA information is current as of publication date. Products conform to specifications per the terms of Texas Instruments standard warranty. Production processing does not necessarily include testing of all parameters.



POST OFFICE BOX 655303 • DALLAS, TEXAS 75265

Copyright © 2004, Texas Instruments Incorporated

SN74LVTH16646-EP

3.3-V ABT 16-BIT BUS TRANSCEIVER WITH 3-STATE OUTPUTS

SCBS786A – NOVEMBER 2003 – REVISED APRIL 2004

description/ordering information (continued)

Output-enable (\overline{OE}) and direction-control (DIR) inputs are provided to control the transceiver functions. In the transceiver mode, data present at the high-impedance port may be stored in either register or in both registers. The select-control (SAB and SBA) inputs can multiplex stored and real-time (transparent mode) data. The circuitry used for select control eliminates the typical decoding glitch that occurs in a multiplexer during the transition between stored and real-time data. DIR determines which bus receives data when \overline{OE} is low. In the isolation mode (\overline{OE} high), A data can be stored in one register and/or B data can be stored in the other register.

When an output function is disabled, the input function still is enabled and can be used to store and transmit data. Only one of the two buses, A or B, can be driven at a time.

Active bus-hold circuitry is provided to hold unused or floating data inputs at a valid logic level.

When V_{CC} is between 0 and 1.5 V, the device is in the high-impedance state during power up or power down. However, to ensure the high-impedance state above 1.5 V, \overline{OE} should be tied to V_{CC} through a pullup resistor; the minimum value of the resistor is determined by the current-sinking capability of the driver.

This device is fully specified for hot-insertion applications using I_{off} and power-up 3-state. The I_{off} circuitry disables the outputs, preventing damaging current backflow through the device when it is powered down. The power-up 3-state circuitry places the outputs in the high-impedance state during power up and power down, which prevents driver conflict.

ORDERING INFORMATION

T_A	PACKAGE†		ORDERABLE PART NUMBER	TOP-SIDE MARKING
-40°C to 85°C	TSSOP – DGG	Tape and reel	CLVTH16646IDGGREP	LH16646EP

† Package drawings, standard packing quantities, thermal data, symbolization, and PCB design guidelines are available at www.ti.com/sc/package.

FUNCTION TABLE

INPUTS						DATA I/O		OPERATION OR FUNCTION
\overline{OE}	DIR	CLKAB	CLKBA	SAB	SBA	A1–A8	B1–B8	
X	X	↑	X	X	X	Input	Unspecified‡	Store A, B unspecified‡
X	X	X	↑	X	X	Unspecified‡	Input	Store B, A unspecified‡
H	X	↑	↑	X	X	Input	Input	Store A and B data
H	X	H or L	H or L	X	X	Input disabled	Input disabled	Isolation, hold storage
L	L	X	X	X	L	Output	Input	Real-time B data to A bus
L	L	X	H or L	X	H	Output	Input	Stored B data to A bus
L	H	X	X	L	X	Input	Output	Real-time A data to B Bus
L	H	H or L	X	H	X	Input	Output	Stored A data to bus

‡ The data-output functions may be enabled or disabled by various signals at \overline{OE} or DIR. Data-input functions always are enabled, i.e., data at the bus terminals is stored on every low-to-high transition of the clock inputs.



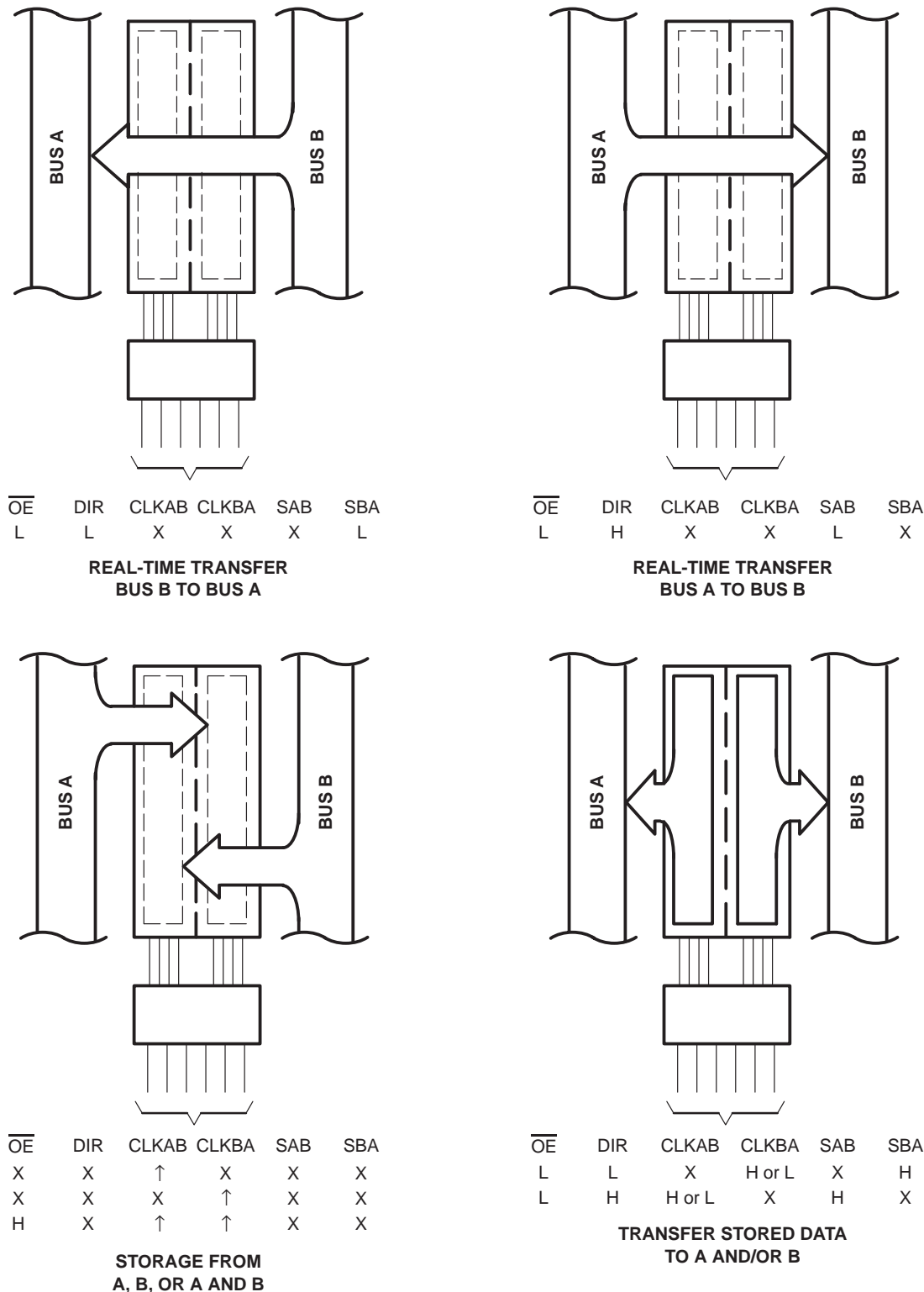
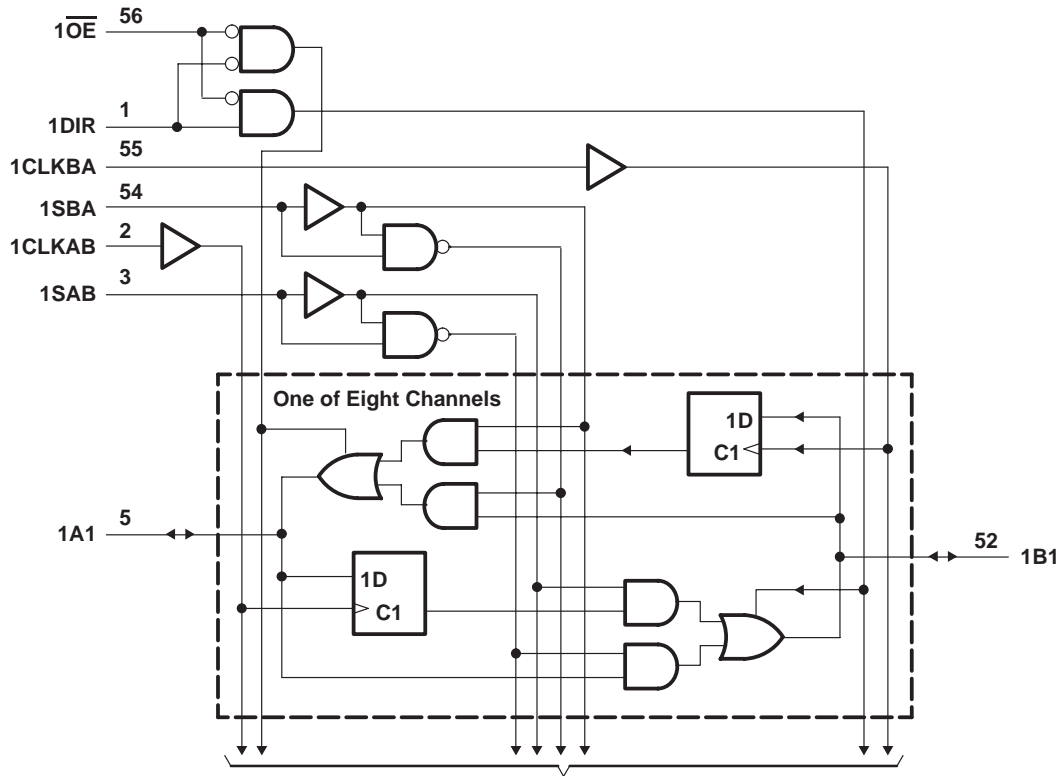

Figure 1. Bus-Management Functions

SN74LVTH16646-EP
3.3-V ABT 16-BIT BUS TRANSCEIVER
WITH 3-STATE OUTPUTS

SCBS786A – NOVEMBER 2003 – REVISED APRIL 2004

logic diagram (positive logic)



To Seven Other Channels

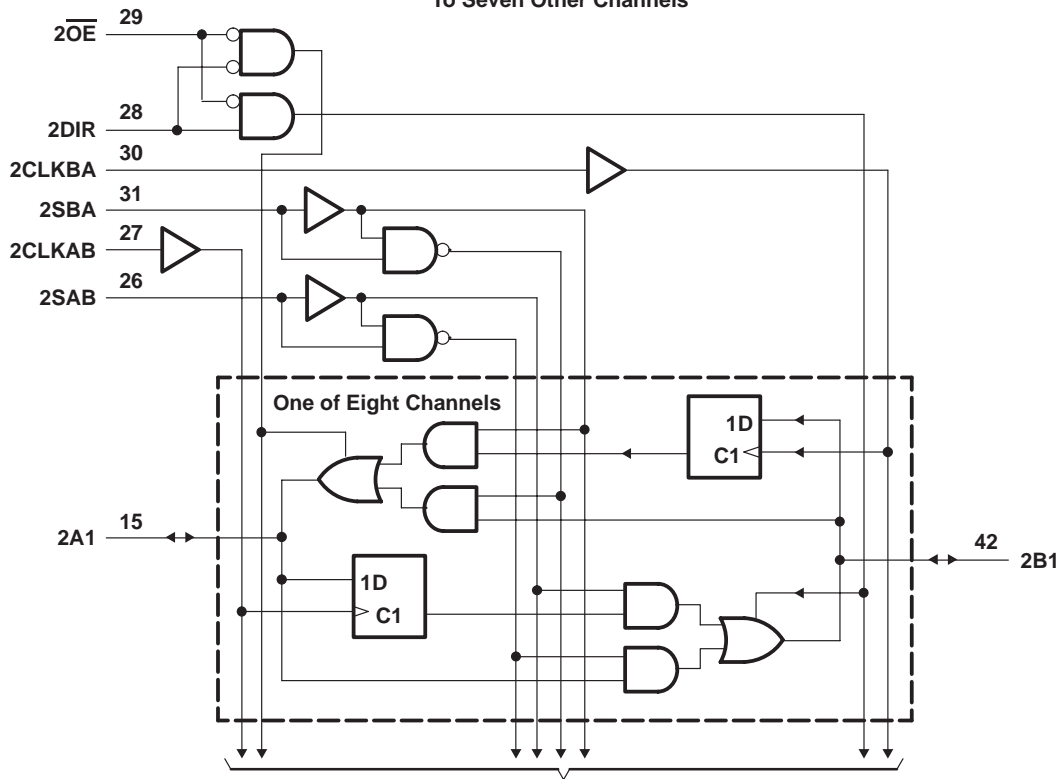

To Seven Other Channels



SN74LVTH16646-EP
3.3-V ABT 16-BIT BUS TRANSCEIVER
WITH 3-STATE OUTPUTS

SCBS786A – NOVEMBER 2003 – REVISED APRIL 2004

absolute maximum ratings over operating free-air temperature range (unless otherwise noted)†

Supply voltage range, V_{CC}	–0.5 V to 4.6 V
Input voltage range, V_I (see Note 1)	–0.5 V to 7 V
Voltage range applied to any output in the high-impedance or power-off state, V_O (see Note 1)	–0.5 V to 7 V
Voltage range applied to any output in the high state, V_O (see Note 1)	–0.5 V to $V_{CC} + 0.5$ V
Current into any output in the low state, I_O	128 mA
Current into any output in the high state, I_O (see Note 2)	64 mA
Input clamp current, I_{IK} ($V_I < 0$)	–50 mA
Output clamp current, I_{OK} ($V_O < 0$)	–50 mA
Package thermal impedance, θ_{JA} (see Note 3)	81°C/W
Storage temperature range, T_{stg}	–65°C to 150°C

† Stresses beyond those listed under “absolute maximum ratings” may cause permanent damage to the device. These are stress ratings only, and functional operation of the device at these or any other conditions beyond those indicated under “recommended operating conditions” is not implied. Exposure to absolute-maximum-rated conditions for extended periods may affect device reliability.

- NOTES: 1. The input and output negative-voltage ratings may be exceeded if the input and output clamp-current ratings are observed.
2. This current flows only when the output is in the high state and $V_O > V_{CC}$.
3. The package thermal impedance is calculated in accordance with JESD 51.

recommended operating conditions (see Note 4)

		MIN	MAX	UNIT
V_{CC}	Supply voltage	2.7	3.6	V
V_{IH}	High-level input voltage	2		V
V_{IL}	Low-level input voltage		0.8	V
V_I	Input voltage		5.5	V
I_{OH}	High-level output current		–32	mA
I_{OL}	Low-level output current		64	mA
$\Delta t/\Delta v$	Input transition rise or fall rate		10	ns/V
				Outputs enabled
$\Delta t/\Delta V_{CC}$	Power-up ramp rate	200		μs/V
T_A	Operating free-air temperature	–40	85	°C

NOTE 4: All unused control inputs of the device must be held at V_{CC} or GND to ensure proper device operation. Refer to the TI application report, *Implications of Slow or Floating CMOS Inputs*, literature number SCBA004.



SN74LVTH16646-EP
3.3-V ABT 16-BIT BUS TRANSCEIVER
WITH 3-STATE OUTPUTS

SCBS786A – NOVEMBER 2003 – REVISED APRIL 2004

electrical characteristics over recommended operating free-air temperature range (unless otherwise noted)

PARAMETER		TEST CONDITIONS		MIN	TYP†	MAX	UNIT		
V _{IK}		V _{CC} = 2.7 V,	I _I = -18 mA			-1.2	V		
V _{OH}		V _{CC} = 2.7 V to 3.6 V,	I _{OH} = -100 μA	V _{CC} -0.2			V		
		V _{CC} = 2.7 V,	I _{OH} = -8 mA	2.4					
		V _{CC} = 3 V,	I _{OH} = -32 mA	2					
V _{OL}		V _{CC} = 2.7 V		I _{OL} = 100 μA		0.2	V		
				I _{OL} = 24 mA		0.5			
		V _{CC} = 3 V		I _{OL} = 16 mA		0.4			
				I _{OL} = 32 mA		0.5			
				I _{OL} = 64 mA		0.55			
I _I		V _{CC} = 3.6 V,		V _I = V _{CC} or GND		±1	μA		
				V _{CC} = 0 or 3.6 V,		V _I = 5.5 V		10	
		A or B ports‡		V _{CC} = 3.6 V		V _I = 5.5 V		20	
						V _I = V _{CC}		1	
				V _I = 0		-5			
I _{off}		V _{CC} = 0,		V _I or V _O = 0 to 4.5 V		±100	μA		
I _{I(hold)}		V _{CC} = 3 V		V _I = 0.8 V		75	μA		
				V _I = 2 V		-75			
		V _{CC} = 3.6 V§,		V _I = 0 to 3.6 V		±500			
I _{OZPU}		V _{CC} = 0 to 1.5 V, V _O = 0.5 V to 3 V, \overline{OE} = don't care				±100	μA		
I _{OZPD}		V _{CC} = 1.5 V to 0, V _O = 0.5 V to 3 V, \overline{OE} = don't care				±100	μA		
I _{CC}		V _{CC} = 3.6 V, I _O = 0, V _I = V _{CC} or GND		Outputs high		0.19	mA		
				Outputs low		5			
				Outputs disabled		0.19			
ΔI _{CC} ¶		V _{CC} = 3 V to 3.6 V, One input at V _{CC} - 0.6 V, Other inputs at V _{CC} or GND				0.2	mA		
C _i		V _I = 3 V or 0				4	pF		
C _{io}		V _O = 3 V or 0				10	pF		

† All typical values are at V_{CC} = 3.3 V, T_A = 25°C.

‡ Unused pins at V_{CC} or GND

§ This is the bus-hold maximum dynamic current. It is the minimum overdrive current required to switch the input from one state to another.

¶ This is the increase in supply current for each input that is at the specified TTL voltage level, rather than V_{CC} or GND.

timing requirements over recommended operating free-air temperature range (unless otherwise noted) (see Figure 2)

		V _{CC} = 3.3 V ± 0.3 V		V _{CC} = 2.7 V		UNIT
		MIN	MAX	MIN	MAX	
f _{clock}	Clock frequency	150		150		MHz
t _w	Pulse duration, CLK high or low	3.3		3.3		ns
t _{su}	Setup time, A or B before CLKAB↑ or CLKBA↑	Data high	1.2	1.5		ns
		Data low	2	2.8		
t _h	Hold time, A or B after CLKAB↑ or CLKBA↑	Data high	0.5	0		ns
		Data low	0.5	0.5		



SN74LVTH16646-EP
3.3-V ABT 16-BIT BUS TRANSCEIVER
WITH 3-STATE OUTPUTS

SCBS786A – NOVEMBER 2003 – REVISED APRIL 2004

switching characteristics over recommended operating free-air temperature range, $C_L = 50$ pF (unless otherwise noted) (see Figure 2)

PARAMETER	FROM (INPUT)	TO (OUTPUT)	$V_{CC} = 3.3\text{ V} \pm 0.3\text{ V}$			$V_{CC} = 2.7\text{ V}$		UNIT
			MIN	TYP†	MAX	MIN	MAX	
f_{max}			150			150		MHz
t_{PLH}	CLKBA or CLKAB	A or B	1.3	2.8	4.2		4.7	ns
t_{PHL}			1.3	2.8	4.2		4.7	
t_{PLH}	A or B	B or A	1	2.4	3.4		3.9	ns
t_{PHL}			1	2.1	3.4		3.9	
t_{PLH}	SBA or SAB‡	A or B	1	2.8	4.5		5.4	ns
t_{PHL}			1	3	4.5		5.4	
t_{PZH}	\overline{OE}	A or B	1	2.5	4.3		5.2	ns
t_{PZL}			1	2.6	4.3		5.2	
t_{PHZ}	\overline{OE}	A or B	2	4	5.6		6.1	ns
t_{PLZ}			2	3.6	5.4		6.1	
t_{PZH}	DIR	A or B	1	3	4.4		5.3	ns
t_{PZL}			1	3	4.4		5.3	
t_{PHZ}	DIR	A or B	1.5	3.9	5.7		6.8	ns
t_{PLZ}			1.5	3.6	5.2		5.7	

† All typical values are at $V_{CC} = 3.3\text{ V}$, $T_A = 25^\circ\text{C}$.

‡ These parameters are measured with the internal output state of the storage register opposite that of the bus input.

SN74LVTH16646-EP
3.3-V ABT 16-BIT BUS TRANSCEIVER
WITH 3-STATE OUTPUTS

SCBS786A – NOVEMBER 2003 – REVISED APRIL 2004

PARAMETER MEASUREMENT INFORMATION

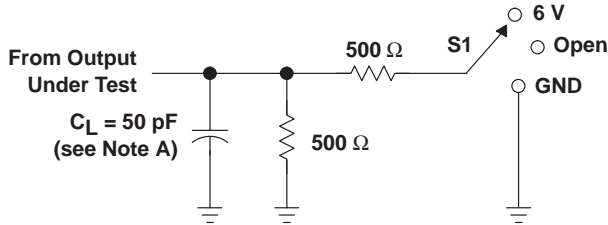

LOAD CIRCUIT

TEST	S1
t_{PLH}/t_{PHL}	Open
t_{PLZ}/t_{PZL}	6 V
t_{PHZ}/t_{PZH}	GND

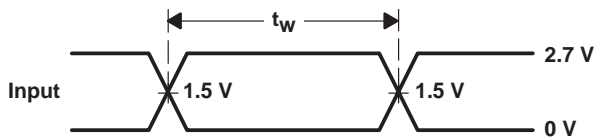

VOLTAGE WAVEFORMS
PULSE DURATION

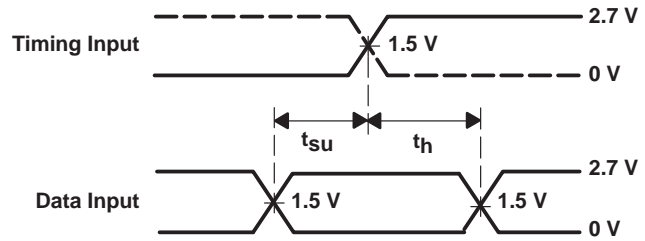

VOLTAGE WAVEFORMS
SETUP AND HOLD TIMES

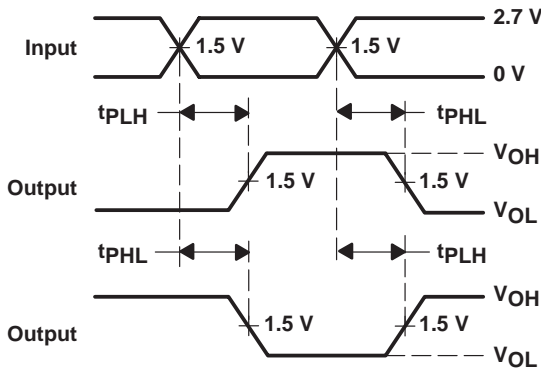

VOLTAGE WAVEFORMS
PROPAGATION DELAY TIMES
INVERTING AND NONINVERTING OUTPUTS

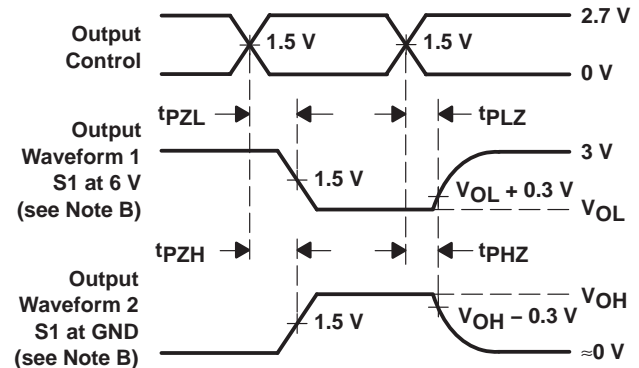

VOLTAGE WAVEFORMS
ENABLE AND DISABLE TIMES
LOW- AND HIGH-LEVEL ENABLING

- NOTES: A. C_L includes probe and jig capacitance.
 B. Waveform 1 is for an output with internal conditions such that the output is low, except when disabled by the output control. Waveform 2 is for an output with internal conditions such that the output is high, except when disabled by the output control.
 C. All input pulses are supplied by generators having the following characteristics: $PRR \leq 10$ MHz, $Z_O = 50 \Omega$, $t_r \leq 2.5$ ns, $t_f \leq 2.5$ ns.
 D. The outputs are measured one at a time, with one transition per measurement.

Figure 2. Load Circuit and Voltage Waveforms

PACKAGING INFORMATION

Orderable Device	Status ⁽¹⁾	Package Type	Package Drawing	Pins	Package Qty	Eco Plan ⁽²⁾	Lead/Ball Finish	MSL Peak Temp ⁽³⁾
CLVTH16646IDGGREP	ACTIVE	TSSOP	DGG	56	2000	Green (RoHS & no Sb/Br)	CU NIPDAU	Level-1-260C-UNLIM
V62/04716-01XE	ACTIVE	TSSOP	DGG	56	2000	Green (RoHS & no Sb/Br)	CU NIPDAU	Level-1-260C-UNLIM

⁽¹⁾ The marketing status values are defined as follows:

ACTIVE: Product device recommended for new designs.

LIFEBUY: TI has announced that the device will be discontinued, and a lifetime-buy period is in effect.

NRND: Not recommended for new designs. Device is in production to support existing customers, but TI does not recommend using this part in a new design.

PREVIEW: Device has been announced but is not in production. Samples may or may not be available.

OBsolete: TI has discontinued the production of the device.

⁽²⁾ Eco Plan - The planned eco-friendly classification: Pb-Free (RoHS), Pb-Free (RoHS Exempt), or Green (RoHS & no Sb/Br) - please check <http://www.ti.com/productcontent> for the latest availability information and additional product content details.

TBD: The Pb-Free/Green conversion plan has not been defined.

Pb-Free (RoHS): TI's terms "Lead-Free" or "Pb-Free" mean semiconductor products that are compatible with the current RoHS requirements for all 6 substances, including the requirement that lead not exceed 0.1% by weight in homogeneous materials. Where designed to be soldered at high temperatures, TI Pb-Free products are suitable for use in specified lead-free processes.

Pb-Free (RoHS Exempt): This component has a RoHS exemption for either 1) lead-based flip-chip solder bumps used between the die and package, or 2) lead-based die adhesive used between the die and leadframe. The component is otherwise considered Pb-Free (RoHS compatible) as defined above.

Green (RoHS & no Sb/Br): TI defines "Green" to mean Pb-Free (RoHS compatible), and free of Bromine (Br) and Antimony (Sb) based flame retardants (Br or Sb do not exceed 0.1% by weight in homogeneous material)

⁽³⁾ MSL, Peak Temp. -- The Moisture Sensitivity Level rating according to the JEDEC industry standard classifications, and peak solder temperature.

Important Information and Disclaimer:The information provided on this page represents TI's knowledge and belief as of the date that it is provided. TI bases its knowledge and belief on information provided by third parties, and makes no representation or warranty as to the accuracy of such information. Efforts are underway to better integrate information from third parties. TI has taken and continues to take reasonable steps to provide representative and accurate information but may not have conducted destructive testing or chemical analysis on incoming materials and chemicals. TI and TI suppliers consider certain information to be proprietary, and thus CAS numbers and other limited information may not be available for release.

In no event shall TI's liability arising out of such information exceed the total purchase price of the TI part(s) at issue in this document sold by TI to Customer on an annual basis.

OTHER QUALIFIED VERSIONS OF SN74LVTH16646-EP :

- Catalog: [SN74LVTH16646](#)

NOTE: Qualified Version Definitions:

- Catalog - TI's standard catalog product

TAPE AND REEL INFORMATION



QUADRANT ASSIGNMENTS FOR PIN 1 ORIENTATION IN TAPE



*All dimensions are nominal

Device	Package Type	Package Drawing	Pins	SPQ	Reel Diameter (mm)	Reel Width W1 (mm)	A0 (mm)	B0 (mm)	K0 (mm)	P1 (mm)	W (mm)	Pin1 Quadrant
CLVTH16646IDGGREP	TSSOP	DGG	56	2000	330.0	24.4	8.6	15.6	1.8	12.0	24.0	Q1

TAPE AND REEL BOX DIMENSIONS



*All dimensions are nominal

Device	Package Type	Package Drawing	Pins	SPQ	Length (mm)	Width (mm)	Height (mm)
CLVTH16646IDGGREP	TSSOP	DGG	56	2000	346.0	346.0	41.0

IMPORTANT NOTICE

Texas Instruments Incorporated and its subsidiaries (TI) reserve the right to make corrections, modifications, enhancements, improvements, and other changes to its products and services at any time and to discontinue any product or service without notice. Customers should obtain the latest relevant information before placing orders and should verify that such information is current and complete. All products are sold subject to TI's terms and conditions of sale supplied at the time of order acknowledgment.

TI warrants performance of its hardware products to the specifications applicable at the time of sale in accordance with TI's standard warranty. Testing and other quality control techniques are used to the extent TI deems necessary to support this warranty. Except where mandated by government requirements, testing of all parameters of each product is not necessarily performed.

TI assumes no liability for applications assistance or customer product design. Customers are responsible for their products and applications using TI components. To minimize the risks associated with customer products and applications, customers should provide adequate design and operating safeguards.

TI does not warrant or represent that any license, either express or implied, is granted under any TI patent right, copyright, mask work right, or other TI intellectual property right relating to any combination, machine, or process in which TI products or services are used. Information published by TI regarding third-party products or services does not constitute a license from TI to use such products or services or a warranty or endorsement thereof. Use of such information may require a license from a third party under the patents or other intellectual property of the third party, or a license from TI under the patents or other intellectual property of TI.

Reproduction of TI information in TI data books or data sheets is permissible only if reproduction is without alteration and is accompanied by all associated warranties, conditions, limitations, and notices. Reproduction of this information with alteration is an unfair and deceptive business practice. TI is not responsible or liable for such altered documentation. Information of third parties may be subject to additional restrictions.

Resale of TI products or services with statements different from or beyond the parameters stated by TI for that product or service voids all express and any implied warranties for the associated TI product or service and is an unfair and deceptive business practice. TI is not responsible or liable for any such statements.

TI products are not authorized for use in safety-critical applications (such as life support) where a failure of the TI product would reasonably be expected to cause severe personal injury or death, unless officers of the parties have executed an agreement specifically governing such use. Buyers represent that they have all necessary expertise in the safety and regulatory ramifications of their applications, and acknowledge and agree that they are solely responsible for all legal, regulatory and safety-related requirements concerning their products and any use of TI products in such safety-critical applications, notwithstanding any applications-related information or support that may be provided by TI. Further, Buyers must fully indemnify TI and its representatives against any damages arising out of the use of TI products in such safety-critical applications.

TI products are neither designed nor intended for use in military/aerospace applications or environments unless the TI products are specifically designated by TI as military-grade or "enhanced plastic." Only products designated by TI as military-grade meet military specifications. Buyers acknowledge and agree that any such use of TI products which TI has not designated as military-grade is solely at the Buyer's risk, and that they are solely responsible for compliance with all legal and regulatory requirements in connection with such use.

TI products are neither designed nor intended for use in automotive applications or environments unless the specific TI products are designated by TI as compliant with ISO/TS 16949 requirements. Buyers acknowledge and agree that, if they use any non-designated products in automotive applications, TI will not be responsible for any failure to meet such requirements.

Following are URLs where you can obtain information on other Texas Instruments products and application solutions:

Products

Amplifiers	amplifier.ti.com
Data Converters	dataconverter.ti.com
DSP	dsp.ti.com
Clocks and Timers	www.ti.com/clocks
Interface	interface.ti.com
Logic	logic.ti.com
Power Mgmt	power.ti.com
Microcontrollers	microcontroller.ti.com
RFID	www.ti-rfid.com
RF/IF and ZigBee® Solutions	www.ti.com/lprf

Applications

Audio	www.ti.com/audio
Automotive	www.ti.com/automotive
Broadband	www.ti.com/broadband
Digital Control	www.ti.com/digitalcontrol
Medical	www.ti.com/medical
Military	www.ti.com/military
Optical Networking	www.ti.com/opticalnetwork
Security	www.ti.com/security
Telephony	www.ti.com/telephony
Video & Imaging	www.ti.com/video
Wireless	www.ti.com/wireless

Mailing Address: Texas Instruments, Post Office Box 655303, Dallas, Texas 75265
Copyright © 2008, Texas Instruments Incorporated