

## SymPol™ Transceiver

 Check for Samples: [SN65HVD96](#)

### FEATURES

- Communicate Without Errors on Normal or Reversed-Wire Bus Lines
- Up to 5 Mbps Signaling
- Industrial Temperature Range:  $-40^{\circ}\text{C}$  to  $85^{\circ}\text{C}$
- Symmetric Polarity Receiver
- Receiver Hysteresis > 100 mV
- Connect up to 32 Nodes Plus Parallel Terminators on one Bus, or Connect up to 200 Nodes on an unterminated Bus
- Transient Protection
  - $\pm 12$  kV Human Body Model on Bus Pins
  - $\pm 25$  V Repetitive Transient Pulse on Bus Pins
- Additional Reliability Features:
  - Bus Standoff From  $-35$  V to 40 V
  - Driver Output Short-Circuit Current Limit
  - Automatic Thermal Shutdown and Recovery
- Complies with ANSI/TIA-4963 Standard

### DESCRIPTION

The SN65HVD96 is specifically designed to meet the requirements for a transceiver which operates with no errors if the twisted-pair signal wires are connected normally or reversed. This allows for error free operation in applications where the signal wires may become inadvertently reversed during installation or maintenance. This feature is corrected internally so no intervention from the controller or operator is required. The SN65HVD96 complies with the requirements of ANSI/TIA-4963, *Electrical Characteristics of Reversible Balanced Voltage Digital Interface Circuits*.

Similar to RS-485, these transceivers can be used for point-to-point, multi-drop, or multi-point networks. SymPol™ devices are not backwards compatible with, but are an upgrade to, existing RS-485 networks. The pin-out is identical to the industry-standard SN75176 transceiver, allowing direct upgrade from RS-485 to SymPol. Current-limited differential outputs protect in case of driver contention on a party-line bus. High receiver input impedance allows connection of at least 32 nodes. Several fault tolerant features are integrated into the device to protect from operational hazards. Current limiting on the driver outputs protects against short-circuit faults, and operates independently on each driver output. An automatic thermal shutdown protects the driver circuits against over temperature conditions. The receiver output enters a deterministic failsafe state if the bus connection is left disconnected or if the bus wires are shorted together.

The small outline integrated circuit (SOIC) package saves board space compared to equivalent discrete implementations. These devices are fully characterized for operation over the industrial temperature range of  $-40^{\circ}\text{C}$  to  $85^{\circ}\text{C}$ .

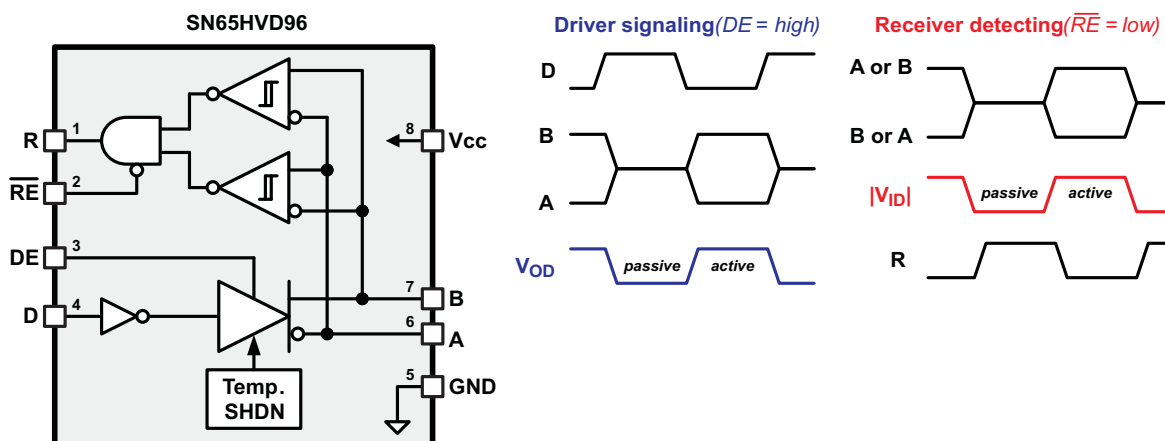

Please be aware that an important notice concerning availability, standard warranty, and use in critical applications of Texas Instruments semiconductor products and disclaimers thereto appears at the end of this data sheet.

SymPol is a trademark of Texas Instruments.

**ABSOLUTE MAXIMUM RATINGS<sup>(1)</sup>**

	VALUE	UNIT
Supply voltage, $V_{CC}$	–0.5 to 6	V
Voltage range at A or B	–35 to 40	V
Voltage range at logic pins (D, DE, $\overline{RE}$ )	–0.3 to $V_{CC}+0.3$	V
Voltage input range, transient pulse, A and B, through 100 $\Omega$	$\pm 25$	V
Voltage input transient pulse, A and B, per ISO 7637	$\pm 200$	V
Differential voltage, $V_A - V_B$	–75 to +75	V
Electro-static discharge per JEDEC Std. 22 A114, A and B pins, Human Body Model	$\pm 12$	kV
Electro-static discharge per JEDEC Std. 22 A114, all pins, Human Body Model	$\pm 5$	kV
Electro-static discharge per JEDEC Std. 22 C101, all pins, Charged Device Model	$\pm 2$	kV
Electro-static discharge per JEDEC Std. 22 A115, all pins, Machine Model	$\pm 200$	V
Receiver output current	$\pm 20$	mA
Junction temperature, $T_J$	170	$^{\circ}\text{C}$
Continuous total power dissipation	(see Dissipation Rating Table)	

- (1) Stresses beyond those listed under "absolute maximum ratings" may cause permanent damage to the device. These are stress ratings only and functional operation of the device at these or any other conditions beyond those indicated under "recommended operating conditions" is not implied. Exposure to absolute-maximum-rated conditions for extended periods may affect device reliability.

**THERMAL INFORMATION**

THERMAL METRIC <sup>(1)</sup>		SN65HVD96	UNITS	
		8 PINS SOIC		
$\theta_{JA}$	Junction-to-ambient thermal resistance <sup>(2)</sup>	124.5	$^{\circ}\text{C}/\text{W}$	
$\theta_{JC(\text{top})}$	Junction-to-case(top) thermal resistance <sup>(3)</sup>	55.9		
$\theta_{JB}$	Junction-to-board thermal resistance <sup>(4)</sup>	50.2		
$\psi_{JT}$	Junction-to-top characterization parameter <sup>(5)</sup>	4.9		
$\psi_{JB}$	Junction-to-board characterization parameter <sup>(6)</sup>	46.0		
$\theta_{JC(\text{bottom})}$	Junction-to-case(bottom) thermal resistance <sup>(7)</sup>	n/a		
$P_d$	Power Dissipation	<b>TEST CONDITIONS</b>		
		VCC = 5.25 V, $T_J = 150^{\circ}\text{C}$ , $R_L = 300\ \Omega$ , $C_L = 50\ \text{pF}$ (driver), $C_L = 15\ \text{pF}$ (receiver), unterminated <sup>(8)</sup>	188	mW
		VCC = 5.25 V, $T_J = 150^{\circ}\text{C}$ , $R_L = 100\ \Omega$ , $C_L = 50\ \text{pF}$ (driver), $C_L = 15\ \text{pF}$ (receiver), RS-422 load <sup>(8)</sup>	251	
VCC = 5.25 V, $T_J = 150^{\circ}\text{C}$ , $R_L = 54\ \Omega$ , $C_L = 50\ \text{pF}$ (driver), $C_L = 15\ \text{pF}$ (receiver), RS-485 load <sup>(8)</sup>	319			

- (1) For more information about traditional and new thermal metrics, see the *IC Package Thermal Metrics* application report, [SPRA953](#).
- (2) The junction-to-ambient thermal resistance under natural convection is obtained in a simulation on a JEDEC-standard, high-K board, as specified in JESD51-7, in an environment described in JESD51-2a.
- (3) The junction-to-case (top) thermal resistance is obtained by simulating a cold plate test on the package top. No specific JEDEC-standard test exists, but a close description can be found in the ANSI SEMI standard G30-88.
- (4) The junction-to-board thermal resistance is obtained by simulating in an environment with a ring cold plate fixture to control the PCB temperature, as described in JESD51-8.
- (5) The junction-to-top characterization parameter,  $\psi_{JT}$ , estimates the junction temperature of a device in a real system and is extracted from the simulation data for obtaining  $\theta_{JA}$ , using a procedure described in JESD51-2a (sections 6 and 7).
- (6) The junction-to-board characterization parameter,  $\psi_{JB}$ , estimates the junction temperature of a device in a real system and is extracted from the simulation data for obtaining  $\theta_{JA}$ , using a procedure described in JESD51-2a (sections 6 and 7).
- (7) The junction-to-case (bottom) thermal resistance is obtained by simulating a cold plate test on the exposed (power) pad. No specific JEDEC standard test exists, but a close description can be found in the ANSI SEMI standard G30-88.
- (8) Driver and receiver enabled, 50% duty cycle square-wave signal at 5 Mbps.

**RECOMMENDED OPERATING CONDITIONS**

		MIN	NOM	MAX	UNIT
$V_{CC}$	Supply voltage	4.75	5	5.25	V
$V_I$	Input voltage at any bus terminal (separately or common mode) <sup>(1)</sup>	-7		12	V
$V_{IH}$	High-level input voltage (Driver, driver enable, and receiver enable inputs)	2		$V_{CC}$	V
$V_{IL}$	Low-level input voltage (Driver, driver enable, and receiver enable inputs)	0		0.8	V
$V_{ID}$	Differential input voltage	-12		12	V
$I_O$	Output current, Driver	-70		70	mA
$I_O$	Output current, Receiver	-2		2	mA
$R_L$	Differential load resistance	54	60		$\Omega$
$1/t_{UI}$	Signaling rate	0		5	Mbps
$T_A$	Operating free-air temperature	-40		85	$^{\circ}\text{C}$

(1) The algebraic convention, in which the least positive (most negative) limit is designated as minimum is used in this data sheet.

**ELECTRICAL CHARACTERISTICS**

over recommended operating conditions (unless otherwise noted)

PARAMETER	TEST CONDITIONS	MIN	TYP	MAX	UNIT		
$ V_{OD(ACT)} $	Driver differential output voltage magnitude (active)				V		
	RS-485 common-mode load, see <a href="#">Figure 2</a>	1.5					
	RS-485 differential load $R_L = 54 \Omega$ , $C_L = \text{Open}$ , see <a href="#">Figure 3</a>	1.5					
	RS-422 differential load $R_L = 100 \Omega$ , $C_L = \text{Open}$ , see <a href="#">Figure 3</a>	2					
$ V_{OD(PAS)} $	Driver differential output voltage magnitude (passive)				mV		
	RS-485 common-mode load, See <a href="#">Figure 2</a>			50			
	RS-485 differential load $R_L = 54 \Omega$ , $C_L = \text{Open}$ , see <a href="#">Figure 3</a>			20			
	RS-422 differential load $R_L = 100 \Omega$ , $C_L = \text{Open}$ , see <a href="#">Figure 3</a>			25			
	No Load			50			
$V_{OC(SS)}$	Steady-state common-mode output voltage	$V_{oc} = (V_A + V_B) / 2$ $R_L = 54 \Omega$		1	$V_{CC}/2$	3	V
$\Delta V_{OC}$	Change in differential driver output common-mode voltage	$V_{oc(D=High)} - V_{oc(D=Low)}$ $R_L = 54 \Omega$		-0.2		0.2	V
$V_{IT(ACT)}$	Active-going receiver differential input threshold	$V_{ID} = V_A - V_B$ or $V_{ID} = V_B - V_A$			775	900	mV
$V_{IT(PASS)}$	Passive-going receiver differential input threshold			500	625		mV
$V_{HYS}$	Receiver differential input threshold hysteresis ( $V_{IT(ACT)} - V_{IT(PASS)}$ )			100	150		mV
$V_{OH}$	Receiver high-level output voltage	$-20 \mu\text{A} \geq I_O \geq -2 \text{ mA}$		2.4		3.7	V
$V_{OL}$	Receiver low-level output voltage	$20 \mu\text{A} \leq I_O \leq 2 \text{ mA}$				0.4	V
$I_I$	Logic pins input current			-100		100	$\mu\text{A}$
$I_{OZ}$	Receiver output high-impedance current	$V_O = 0 \text{ V}$ or $V_{CC}$ , $\overline{RE}$ at $V_{CC}$		-10		10	$\mu\text{A}$
$I_{OS}$	Driver short-circuit output current	$-7 \text{ V} < V_O < +12 \text{ V}$		-350		350	mA
$I_I$	Bus input current (passive driver)	$V_{CC} = 4.75 \text{ to } 5.25 \text{ V}$ or $V_{CC} = 0 \text{ V}$ , DE at $0 \text{ V}$ , other bus pin at $0 \text{ V}$			$V_I = 12 \text{ V}$	1	mA
			$V_I = -7 \text{ V}$	-0.8		mA	
$I_{CC}$	Supply current (quiescent), no load					20	mA
$R_{ID}$	Differential input resistance	DE at $0 \text{ V}$ , $V_{cm} = V_{CC}/2$		24	40	57	k $\Omega$

**SWITCHING CHARACTERISTICS**

over recommended operating conditions (unless otherwise noted)

PARAMETER	TEST CONDITIONS	MIN	TYP	MAX	UNIT
<b>DRIVER</b>					
$t_{rise}, t_{fall}$	Driver differential output rise/fall time		15	30	ns
$t_{pAP}, t_{pPA}$	Driver propagation delay	$R_L = 54 \Omega, C_L = 50 \text{ pF}$ , See <a href="#">Figure 3</a>	40	80	ns
$t_{SK(P)}$	Driver differential output pulse skew, $ t_{pAP} - t_{pPA} $		1	10	ns
$t_{pZA}, t_{pAZ}$	Driver enable/disable time	$D = \text{GND}, R_L = 54 \Omega, C_L = 50 \text{ pF}$ , See <a href="#">Figure 4</a>	50	80	ns
<b>RECEIVER</b>					
$t_{rise}, t_{fall}$	Receiver output rise/fall time	$C_L = 15 \text{ pF}$ , See <a href="#">Figure 5</a>	8	15	ns
$t_{PHL}, t_{PLH}$	Receiver propagation delay time		70	90	ns
$t_{SK(P)}$	Receiver output pulse skew, $ t_{PHL} - t_{PLH} $		5	15	ns
$t_{PZL}, t_{PZH}, t_{PLZ}, t_{PHZ}$	Receiver enable/disable time	See <a href="#">Figure 6</a>	20	100	ns

**FUNCTION TABLE**

DRIVER	DE	D	$V_{OD}$	
	L or OPEN	X	Z	Driver Disabled (Passive)
	H	L	H	Driver Active
		H or Open	Z	Driver Passive
RECEIVER	$\overline{RE}$	$V_{ID}$	R	
	H or OPEN	X	Z	Receiver Disabled
	L	$V_{ID} < -0.9 \text{ V}$	L	Active Bit Received
		$-0.9 \text{ V} < V_{ID} < -0.5 \text{ V}$	?	Indeterminate bus
		$-0.5 \text{ V} < V_{ID} < 0.5 \text{ V}$	H	Passive Bit Received
		$0.5 \text{ V} < V_{ID} < 0.9 \text{ V}$	?	Indeterminate bus
		$0.9 \text{ V} < V_{ID}$	L	Active Bit Received
		Open, Short, Idle	H	Failsafe Condition

DEVICE INFORMATION

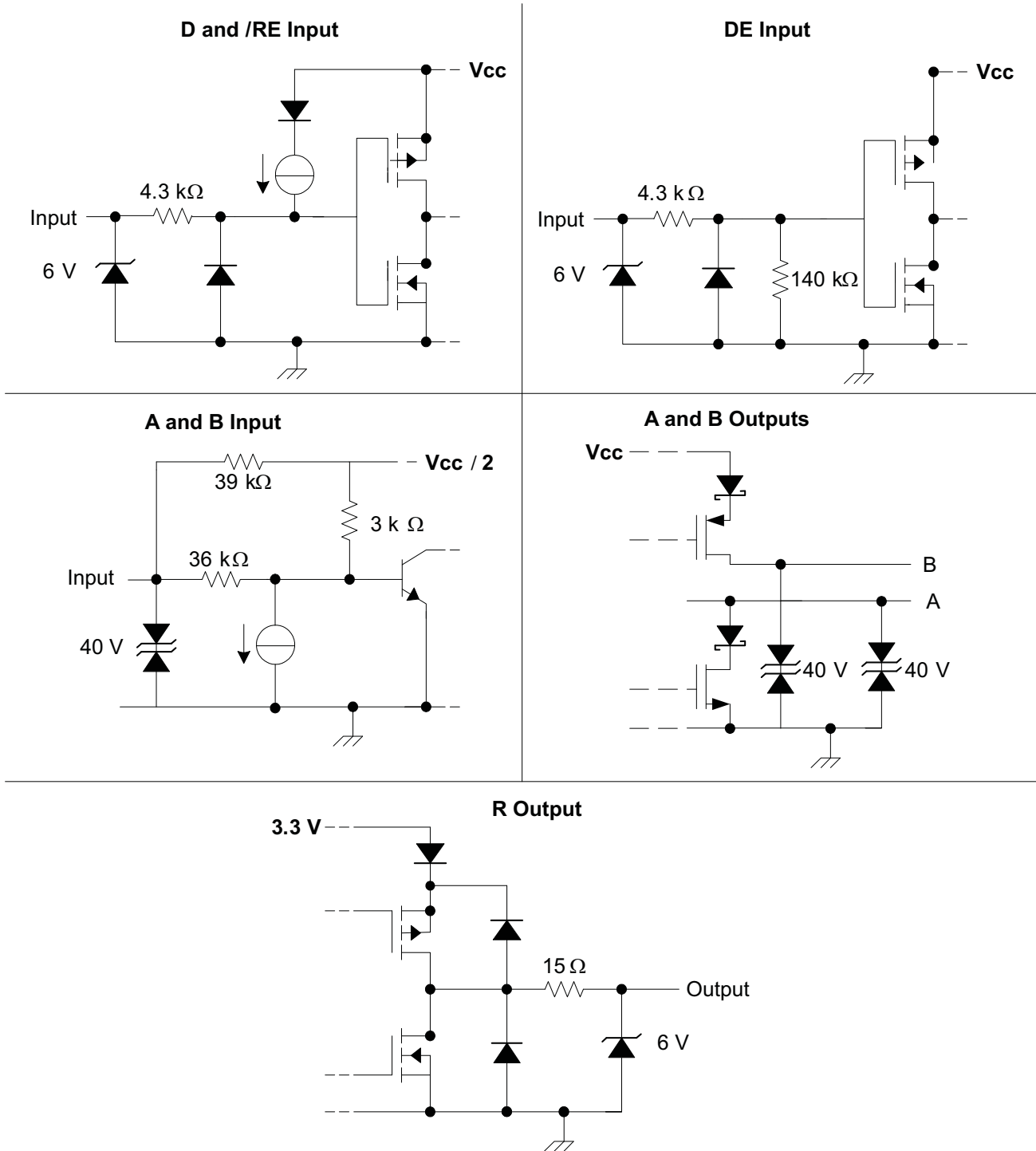

Figure 1. Equivalent Input and Output Schematic Diagrams

**APPLICATION INFORMATION**

**SymPol™ States**

**Sym-Pol\* States**

- If the differential voltage is positive ( $V_A > V_B$ ) the state is called ACTIVE
- If the differential voltage is near zero ( $V_A \approx V_B$ ) the state is called PASSIVE
- If the differential voltage is negative ( $V_A < V_B$ ) the state is called ACTIVE

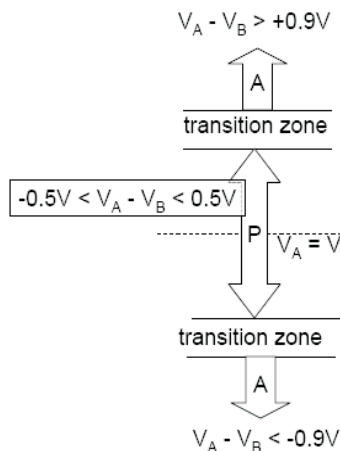

\*Symmetric polarity

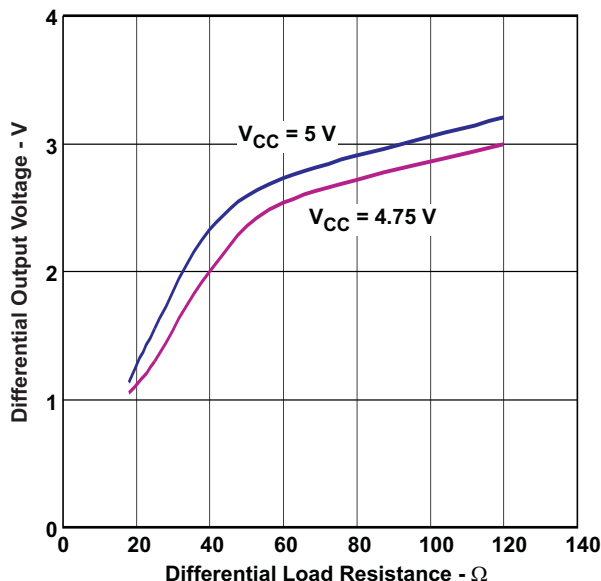

**Using SymPol to Achieve Immunity to Crossed Bus Wire**

Many applications which use RS-422 or RS-485 are wired on-site by third-party installers. This opens the door to the possibility of miss-wiring, especially for far-flung networks with many stations (or nodes). Neither RS-422 nor RS-485 allows correct communications when the bus wires (typically a twisted-pair) are swapped.

The existing solutions for this case require active intervention, either by the installer or maintenance technician, or by an automated controller. SymPol offers a way to replace RS-422 or RS-485 networks with communication over the same bus lines. Due to the innovative nature of SymPol signaling levels, a SymPol network is immune to communication errors caused by crossed bus wires.

Signaling levels are similar to RS-422 and RS-485, so signaling rates, cable lengths, and noise immunity will be comparable.

SymPol is NOT interoperable with RS-422 or RS-485; that is, designers may not mix SymPol nodes with existing RS-485 nodes.

## Number of Nodes

The SN65HV96 specifications for bus-pin impedance are similar to a standard one unit-load (1 UL) RS-485 device. This allows designers to attach up to 32 nodes plus two parallel termination resistors on a single bus segment. In applications where the standard trunk-and-stub arrangement of RS-485 is not practical, or if mis-termination may occur during installation, it may be desirable to not use parallel termination on the bus lines. In these applications, the number of nodes allowed can be up to about 200, while still maintaining high driver output amplitude. The bus pin impedance is approximated as 12 k $\Omega$ , therefore 200 devices in parallel present differential loading similar to the 60  $\Omega$  termination resistance.

## PARAMETER MEASUREMENT INFORMATION

Input generator rate is 100kbps, 50% duty-cycle, transition times less than 6 ns for all figures.

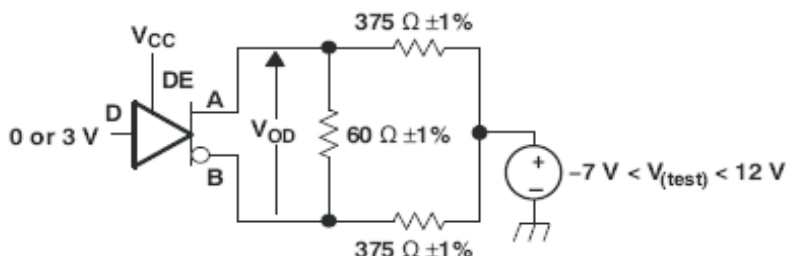

Figure 2. Measurement of Driver Differential Output Voltage With Common-Mode Load

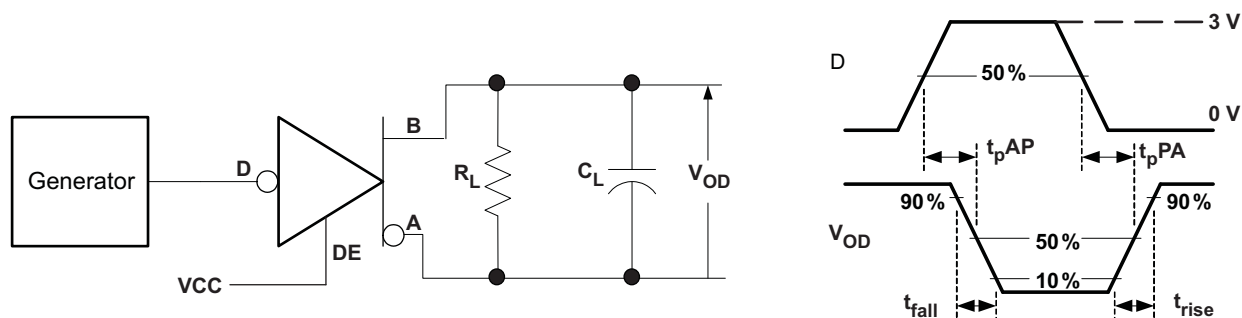

Figure 3. Measurements of Driver Differential Output Rise and Fall Times and Propagation delays

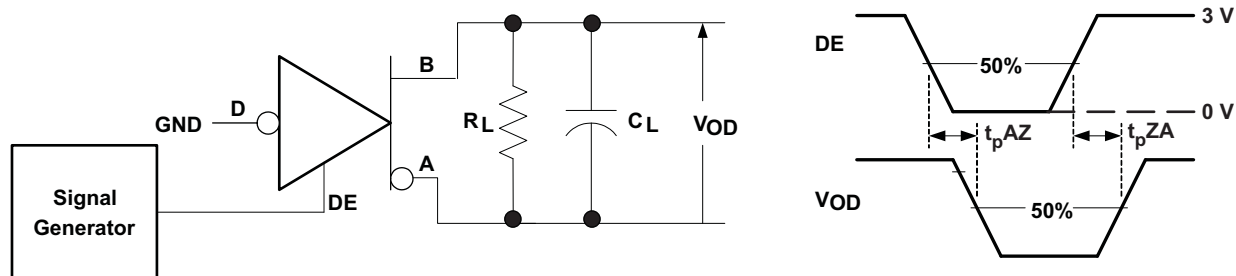

Figure 4. Measurements of Driver Enable and Disable Times With Active Output

PARAMETER MEASUREMENT INFORMATION (continued)

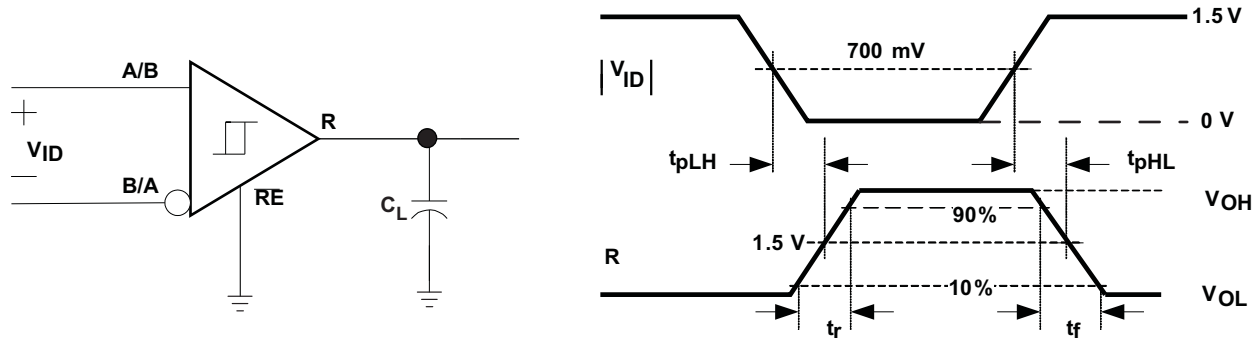

Figure 5. Measurement of Receiver Output Rise and Fall Times and Propagation Delays

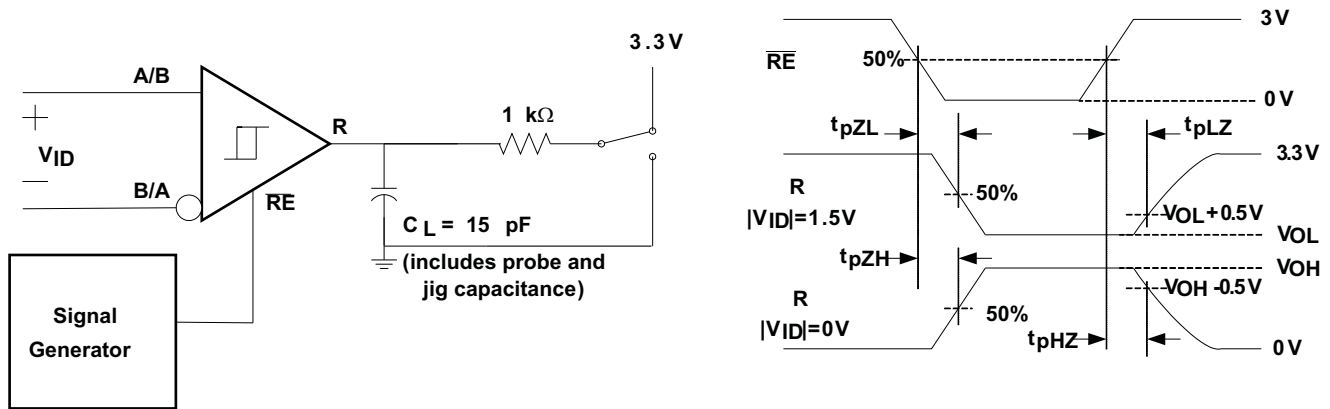

Figure 6. Measurement of Receiver Enable Times With Driver Disabled



## REVISION HISTORY

<b>Changes from Original (June 2010) to Revision A</b>	<b>Page</b>
• Changed the 4th bullet in Features to 2 bulleted items .....	1
• Changed the 6th bullet in Features to read "Connect up to 32 Nodes Plus Parallel Terminators on one Bus, or Connect up to 200 Nodes on an Unterminated Bus" .....	1
• Deleted italics from party line and failsafe in second paragraph .....	1
• Added to protect after Several fault.....into the device sentence, second paragraph .....	1
• Changed in abs max table from 7V to 6V .....	2
• Deleted deleted 'dc' from the VALUE column in 2nd and 4th parameter .....	2
• Added commas after the name of the test specification, A224, 2 places, C101 and A115. Added the word pins after A and B in the first Human Body Model row .....	2
• Deleted 290 in the THERMAL Table from the first cell under TEST Conditions. Deleted 5V supply from all three cells. ....	2
• Added typical characteristics graph to Application Information Section .....	6
• Added section to Application Information titled Number of Nodes .....	7

<b>Changes from Revision A (December 2010) to Revision B</b>	<b>Page</b>
• Changed revision A, December 2010 to Rev B, October 2011 .....	1
• Added new ListItem to the FEATURES: 'Complies .....Standard' .....	1
• Added last sentence to the first paragraph of DESCRIPTION .....	1
• Added Differential voltage.....V row to the ABS MAX RATINGS table .....	2
• Added differential input resistance specification to Electrical Characteristics table. ....	3

**PACKAGING INFORMATION**

Orderable Device	Status <sup>(1)</sup>	Package Type	Package Drawing	Pins	Package Qty	Eco Plan <sup>(2)</sup>	Lead/ Ball Finish	MSL Peak Temp <sup>(3)</sup>	Samples (Requires Login)
SN65HVD96D	ACTIVE	SOIC	D	8	75	Green (RoHS & no Sb/Br)	CU NIPDAU	Level-1-260C-UNLIM	
SN65HVD96DR	ACTIVE	SOIC	D	8	2500	Green (RoHS & no Sb/Br)	CU NIPDAU	Level-1-260C-UNLIM	

<sup>(1)</sup> The marketing status values are defined as follows:

**ACTIVE:** Product device recommended for new designs.

**LIFEBUY:** TI has announced that the device will be discontinued, and a lifetime-buy period is in effect.

**NRND:** Not recommended for new designs. Device is in production to support existing customers, but TI does not recommend using this part in a new design.

**PREVIEW:** Device has been announced but is not in production. Samples may or may not be available.

**OBSOLETE:** TI has discontinued the production of the device.

<sup>(2)</sup> Eco Plan - The planned eco-friendly classification: Pb-Free (RoHS), Pb-Free (RoHS Exempt), or Green (RoHS & no Sb/Br) - please check <http://www.ti.com/productcontent> for the latest availability information and additional product content details.

**TBD:** The Pb-Free/Green conversion plan has not been defined.

**Pb-Free (RoHS):** TI's terms "Lead-Free" or "Pb-Free" mean semiconductor products that are compatible with the current RoHS requirements for all 6 substances, including the requirement that lead not exceed 0.1% by weight in homogeneous materials. Where designed to be soldered at high temperatures, TI Pb-Free products are suitable for use in specified lead-free processes.

**Pb-Free (RoHS Exempt):** This component has a RoHS exemption for either 1) lead-based flip-chip solder bumps used between the die and package, or 2) lead-based die adhesive used between the die and leadframe. The component is otherwise considered Pb-Free (RoHS compatible) as defined above.

**Green (RoHS & no Sb/Br):** TI defines "Green" to mean Pb-Free (RoHS compatible), and free of Bromine (Br) and Antimony (Sb) based flame retardants (Br or Sb do not exceed 0.1% by weight in homogeneous material)

<sup>(3)</sup> MSL, Peak Temp. -- The Moisture Sensitivity Level rating according to the JEDEC industry standard classifications, and peak solder temperature.

**Important Information and Disclaimer:** The information provided on this page represents TI's knowledge and belief as of the date that it is provided. TI bases its knowledge and belief on information provided by third parties, and makes no representation or warranty as to the accuracy of such information. Efforts are underway to better integrate information from third parties. TI has taken and continues to take reasonable steps to provide representative and accurate information but may not have conducted destructive testing or chemical analysis on incoming materials and chemicals. TI and TI suppliers consider certain information to be proprietary, and thus CAS numbers and other limited information may not be available for release.

In no event shall TI's liability arising out of such information exceed the total purchase price of the TI part(s) at issue in this document sold by TI to Customer on an annual basis.

**TAPE AND REEL INFORMATION**
**REEL DIMENSIONS**

**TAPE DIMENSIONS**

A0	Dimension designed to accommodate the component width
B0	Dimension designed to accommodate the component length
K0	Dimension designed to accommodate the component thickness
W	Overall width of the carrier tape
P1	Pitch between successive cavity centers

**TAPE AND REEL INFORMATION**

\*All dimensions are nominal

Device	Package Type	Package Drawing	Pins	SPQ	Reel Diameter (mm)	Reel Width W1 (mm)	A0 (mm)	B0 (mm)	K0 (mm)	P1 (mm)	W (mm)	Pin1 Quadrant
SN65HVD96DR	SOIC	D	8	2500	330.0	12.4	6.4	5.2	2.1	8.0	12.0	Q1

TAPE AND REEL BOX DIMENSIONS



\*All dimensions are nominal

Device	Package Type	Package Drawing	Pins	SPQ	Length (mm)	Width (mm)	Height (mm)
SN65HVD96DR	SOIC	D	8	2500	367.0	367.0	35.0

D (R-PDSO-G8)

PLASTIC SMALL OUTLINE



- NOTES:
- A. All linear dimensions are in inches (millimeters).
  - B. This drawing is subject to change without notice.
  - C. Body length does not include mold flash, protrusions, or gate burrs. Mold flash, protrusions, or gate burrs shall not exceed 0.006 (0,15) each side.
  - D. Body width does not include interlead flash. Interlead flash shall not exceed 0.017 (0,43) each side.
  - E. Reference JEDEC MS-012 variation AA.

D (R-PDSO-G8)

PLASTIC SMALL OUTLINE



- NOTES:
- A. All linear dimensions are in millimeters.
  - B. This drawing is subject to change without notice.
  - C. Publication IPC-7351 is recommended for alternate designs.
  - D. Laser cutting apertures with trapezoidal walls and also rounding corners will offer better paste release. Customers should contact their board assembly site for stencil design recommendations. Refer to IPC-7525 for other stencil recommendations.
  - E. Customers should contact their board fabrication site for solder mask tolerances between and around signal pads.

## IMPORTANT NOTICE

Texas Instruments Incorporated and its subsidiaries (TI) reserve the right to make corrections, enhancements, improvements and other changes to its semiconductor products and services per JESD46C and to discontinue any product or service per JESD48B. Buyers should obtain the latest relevant information before placing orders and should verify that such information is current and complete. All semiconductor products (also referred to herein as "components") are sold subject to TI's terms and conditions of sale supplied at the time of order acknowledgment.

TI warrants performance of its components to the specifications applicable at the time of sale, in accordance with the warranty in TI's terms and conditions of sale of semiconductor products. Testing and other quality control techniques are used to the extent TI deems necessary to support this warranty. Except where mandated by applicable law, testing of all parameters of each component is not necessarily performed.

TI assumes no liability for applications assistance or the design of Buyers' products. Buyers are responsible for their products and applications using TI components. To minimize the risks associated with Buyers' products and applications, Buyers should provide adequate design and operating safeguards.

TI does not warrant or represent that any license, either express or implied, is granted under any patent right, copyright, mask work right, or other intellectual property right relating to any combination, machine, or process in which TI components or services are used. Information published by TI regarding third-party products or services does not constitute a license to use such products or services or a warranty or endorsement thereof. Use of such information may require a license from a third party under the patents or other intellectual property of the third party, or a license from TI under the patents or other intellectual property of TI.

Reproduction of significant portions of TI information in TI data books or data sheets is permissible only if reproduction is without alteration and is accompanied by all associated warranties, conditions, limitations, and notices. TI is not responsible or liable for such altered documentation. Information of third parties may be subject to additional restrictions.

Resale of TI components or services with statements different from or beyond the parameters stated by TI for that component or service voids all express and any implied warranties for the associated TI component or service and is an unfair and deceptive business practice. TI is not responsible or liable for any such statements.

Buyer acknowledges and agrees that it is solely responsible for compliance with all legal, regulatory and safety-related requirements concerning its products, and any use of TI components in its applications, notwithstanding any applications-related information or support that may be provided by TI. Buyer represents and agrees that it has all the necessary expertise to create and implement safeguards which anticipate dangerous consequences of failures, monitor failures and their consequences, lessen the likelihood of failures that might cause harm and take appropriate remedial actions. Buyer will fully indemnify TI and its representatives against any damages arising out of the use of any TI components in safety-critical applications.

In some cases, TI components may be promoted specifically to facilitate safety-related applications. With such components, TI's goal is to help enable customers to design and create their own end-product solutions that meet applicable functional safety standards and requirements. Nonetheless, such components are subject to these terms.

No TI components are authorized for use in FDA Class III (or similar life-critical medical equipment) unless authorized officers of the parties have executed a special agreement specifically governing such use.

Only those TI components which TI has specifically designated as military grade or "enhanced plastic" are designed and intended for use in military/aerospace applications or environments. Buyer acknowledges and agrees that any military or aerospace use of TI components which have **not** been so designated is solely at the Buyer's risk, and that Buyer is solely responsible for compliance with all legal and regulatory requirements in connection with such use.

TI has specifically designated certain components which meet ISO/TS16949 requirements, mainly for automotive use. Components which have not been so designated are neither designed nor intended for automotive use; and TI will not be responsible for any failure of such components to meet such requirements.

### Products

Audio	<a href="http://www.ti.com/audio">www.ti.com/audio</a>
Amplifiers	<a href="http://amplifier.ti.com">amplifier.ti.com</a>
Data Converters	<a href="http://dataconverter.ti.com">dataconverter.ti.com</a>
DLP® Products	<a href="http://www.dlp.com">www.dlp.com</a>
DSP	<a href="http://dsp.ti.com">dsp.ti.com</a>
Clocks and Timers	<a href="http://www.ti.com/clocks">www.ti.com/clocks</a>
Interface	<a href="http://interface.ti.com">interface.ti.com</a>
Logic	<a href="http://logic.ti.com">logic.ti.com</a>
Power Mgmt	<a href="http://power.ti.com">power.ti.com</a>
Microcontrollers	<a href="http://microcontroller.ti.com">microcontroller.ti.com</a>
RFID	<a href="http://www.ti-rfid.com">www.ti-rfid.com</a>
OMAP Mobile Processors	<a href="http://www.ti.com/omap">www.ti.com/omap</a>
Wireless Connectivity	<a href="http://www.ti.com/wirelessconnectivity">www.ti.com/wirelessconnectivity</a>

### Applications

Automotive and Transportation	<a href="http://www.ti.com/automotive">www.ti.com/automotive</a>
Communications and Telecom	<a href="http://www.ti.com/communications">www.ti.com/communications</a>
Computers and Peripherals	<a href="http://www.ti.com/computers">www.ti.com/computers</a>
Consumer Electronics	<a href="http://www.ti.com/consumer-apps">www.ti.com/consumer-apps</a>
Energy and Lighting	<a href="http://www.ti.com/energy">www.ti.com/energy</a>
Industrial	<a href="http://www.ti.com/industrial">www.ti.com/industrial</a>
Medical	<a href="http://www.ti.com/medical">www.ti.com/medical</a>
Security	<a href="http://www.ti.com/security">www.ti.com/security</a>
Space, Avionics and Defense	<a href="http://www.ti.com/space-avionics-defense">www.ti.com/space-avionics-defense</a>
Video and Imaging	<a href="http://www.ti.com/video">www.ti.com/video</a>

**TI E2E Community** [e2e.ti.com](http://e2e.ti.com)