

## OVERVIEW

The SM1124 Series are melody pager multi-melody ICs fabricated in NPC's Molybdenum-gate CMOS. A maximum of 16 tunes can be stored in programmable ROM, and the Molybdenum-gate CMOS process realizes small-sized packages and low power dissipation.

## FEATURES

- Maximum of 16 tune selections (with up to 512 steps)
- Level hold playback mode
- External reference clock input. The frequency can be selected from the following 12 settings.
  - Playback frequency of each song varies (8 frequencies)
    - 32.768 kHz system: 32.768 and 65.536 kHz
    - 37.5 kHz system: 37.5 and 75.0 kHz
    - 38.4 kHz system: 38.4 and 76.8 kHz
    - 48.0 kHz system: 48.0 and 96.0 kHz
  - Playback frequency of all songs is fixed (4 frequencies)
    - 32.768 kHz system: 131.072 kHz
    - 37.5 kHz system: 150.0 kHz
    - 38.4 kHz system: 153.6 kHz
    - 48.0 kHz system: 192.0 kHz
- 2-pin serial data tune selection
- Power save function
- External clock gating in non-play mode.
- 2.4 to 3.6 V supply voltage
- 8-pin plastic SOP package
- Molybdenum-gate CMOS process

## PINOUT

### 8-pin SOP

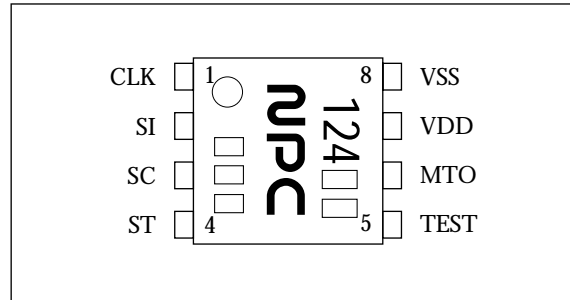

## PACKAGE DIMENSIONS

Unit: mm

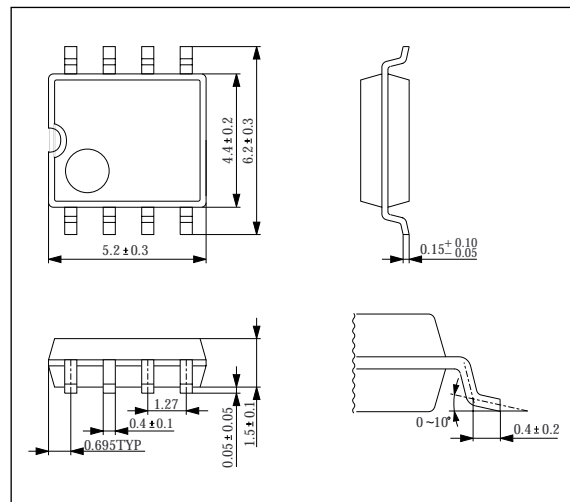

**BLOCK DIAGRAM**

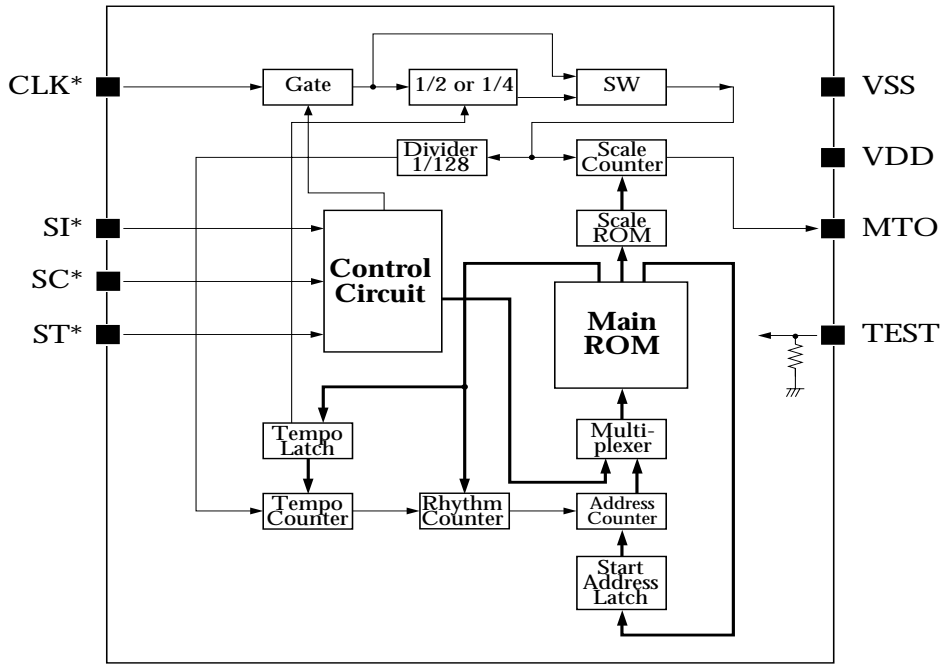

\*: Built-in Schmitt-Triger Circuit.

**PIN DESCRIPTION**

Number	Name	I/O	Function
1	CLK	I	External reference clock input (Schmitt-trigger circuit and gate circuit built-in)
2	SI	I	Playback control serial interface data input pin <sup>1</sup>
3	SC	I	Playback control serial interface clock input pin <sup>1</sup>
4	ST	I	Playback start/stop control signal input pin <sup>1</sup>
5	TEST	I	Test input pin. Leave open or tie to VSS. (Pull-down resistance built-in)
6	MTO	O	Playback signal output pin
7	VDD	-	Supply pin (+)
8	VSS	-	Ground pin

1. Pins SI, SC and ST have a built-in Schmitt-trigger circuit.

**SPECIFICATIONS**

**Absolute Maximum Ratings**

Parameter	Symbol	Condition	Rating	Unit
Supply voltage range	$V_{DD}$		-0.3 to 5.0	V
Input voltage range	$V_{IN}$		$V_{SS} - 0.2$ to $V_{DD} + 0.2$	V
Power dissipation	$P_D$		150	mW
Storage temperature range	$T_{stg}$		-40 to 125	°C
Soldering temperature	$T_{sld}$		255	°C
Soldering time	$t_{sld}$		10	s

## Recommended Operating Conditions

$V_{SS} = 0$  V unless otherwise specified

Parameter	Symbol	Condition	Rating			Unit
			min	typ	max	
Supply voltage	$V_{DD}$		2.4	–	3.6	V
Operating temperature	$T_{opr}$		–20	–	70	°C

## DC Characteristics

$T_a = -20$  to  $70$  °C,  $V_{SS} = 0$  V,  $V_{DD} = 2.4$  to  $3.6$  V unless otherwise specified

Parameter	Symbol	Condition	Rating			Unit
			min	typ	max	
Supply voltage	$V_{DD}$		2.4	3.0	3.6	V
Current consumption (1)	$I_{DD1}$	Non-playback mode, 25°C	–	–	0.5	μA
Current consumption (2)	$I_{DD2}$	Playback mode, MTO pin open	–	25	200	μA
Input voltage	$V_{IH}$	ST, SI, SC and CLK pins	$V_{DD} - 0.2$	–	$V_{DD}$	V
	$V_{IL}$		$V_{SS}$	–	$V_{SS} + 0.2$	V
Hysteresis width	$V_T$		0.2	1.0	–	V
Input current	$I_{IH1}$	ST, SI, SC and CLK pins, $V_{IH} = V_{DD}$ , 25°C	–	–	0.5	μA
	$I_{IL1}$	ST, SI, SC and CLK pins, $V_{IL} = 0$ V, 25°C	–	–	0.5	μA
	$I_{IH2}$	TEST pin, $V_{IH} = V_{DD}$	–	–	200	μA
Open voltage	$V_{OPN}$	TEST pin	–	–	0.1	V
Output voltage	$V_{OH}$	MTO pin, $I_{OH} = 1$ mA	$V_{DD} - 0.4$	–	$V_{DD}$	V
	$V_{OL}$	MTO pin, $I_{OL} = 1$ mA	$V_{SS}$	–	$V_{SS} + 0.4$	V

## AC Characteristics

$T_a = -20$  to  $70$  °C,  $V_{SS} = 0$  V,  $V_{DD} = 2.4$  to  $3.6$  V unless otherwise specified

Parameter	Symbol	Condition	Rating			Unit
			min	typ	max	
CLK pulse cycle	$t_{CLK}$	"CLK input clock" timing	5.0	–	–	μs
CLK HIGH-level pulsewidth	$t_{CWH}$		2.0	–	–	μs
CLK LOW-level pulsewidth	$t_{CWL}$		2.0	–	–	μs
SC pulsewidth	$t_{SC}$	"SC input clock" timing	5.0	–	–	μs
SC HIGH-level pulsewidth	$t_{SWH}$		2.0	–	–	μs
SC LOW-level pulsewidth	$t_{SWL}$		2.0	–	–	μs
SI-SC setup time	$t_{DS}$	"Serial input" timing	2.0	–	–	μs
SI-SC hold time	$t_{DH}$		2.0	–	–	μs

**CLK input clock**

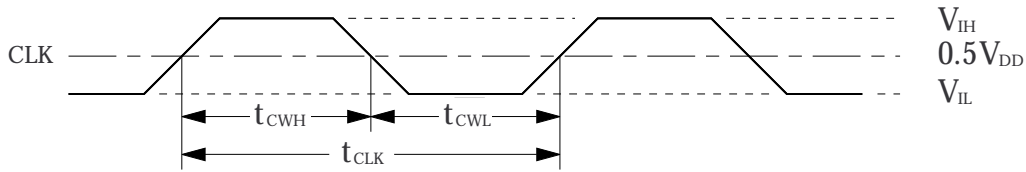

**SC input clock**

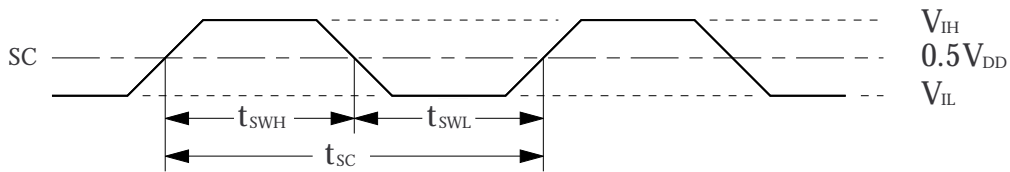

**Serial input**

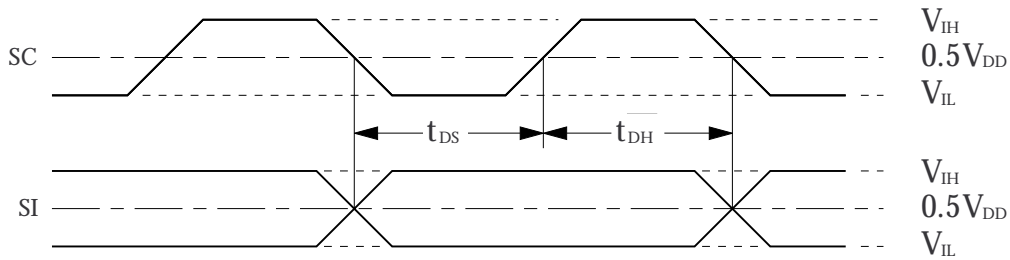

**FUNCTIONAL DESCRIPTION**

**Control Functions**

**External reference clock**

The SM1124 can operate at 12 selectable external reference clock frequencies. Of these, 8 are selectable for each tune. When multiple external clock frequencies are input to a single IC, the clock must be switched during playback mode. Note that when the frequency in parentheses is selected, all tunes can only be played using that single fixed frequency.

- 32.768 kHz system: 32.768 kHz, 65.536 kHz, (131.072 kHz)
- 37.5 kHz system: 37.5 kHz, 75.0 kHz, (150.0 kHz)
- 38.4 kHz system: 38.4 kHz, 76.8 kHz, (153.6 kHz)
- 48.0 kHz system: 48.0 kHz, 96.0 kHz, (192.0 kHz)

The external reference clock input is used at any time as well as during playback mode. If a clock signal is input when not in playback mode (when ST is LOW), the gate circuit switches to cutoff the external reference clock signal from entering the device, preventing unwanted current flow.

**Input during playback mode only**

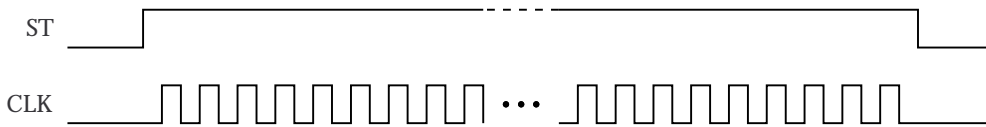

**Input during non-playback mode**

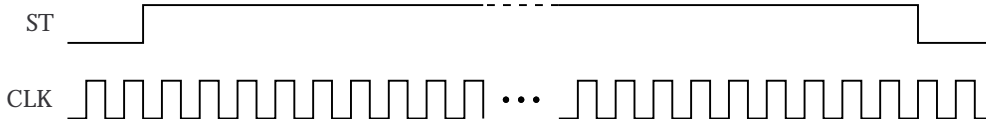

**Playback control**

The ST pin controls the start of playback. While ST is HIGH (VDD), the tune is played repeatedly, and when ST goes LOW (VSS), playback stops. Tunes are selected by the input serial data on pins SI and

SC. The final 4 bits form the valid selection data, and this data is retained even after playback.

If serial data is input during playback, the SM1124 ignores this data and playback continues.

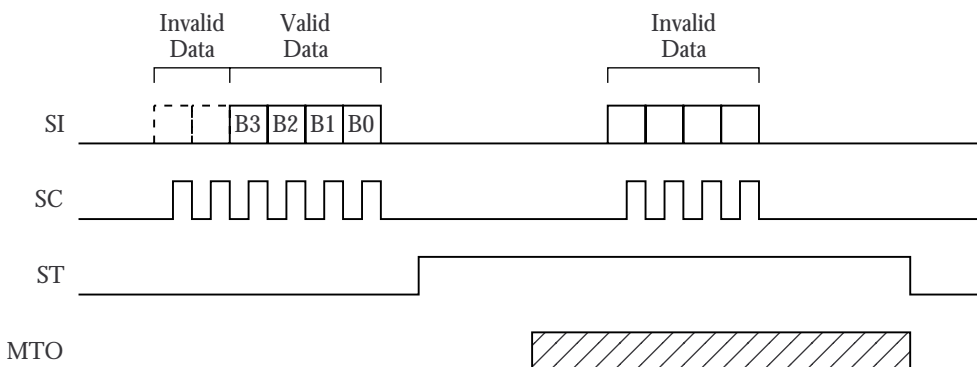

\* Pin SC should be LOW when either a LOW-to-HIGH or HIGH-to-LOW transition occurs on pin ST.

**Serial data selection<sup>1</sup>**

B3	B2	B1	B0	ST	Music selection
L	L	L	L	L → H	1st tune
L	L	L	H	L → H	2nd tune
L	L	H	L	L → H	3rd tune
L	L	H	H	L → H	4th tune
L	H	L	L	L → H	5th tune
L	H	L	H	L → H	6th tune
L	H	H	L	L → H	7th tune
L	H	H	H	L → H	8th tune

B3	B2	B1	B0	ST	Music selection
H	L	L	L	L → H	9th tune
H	L	L	H	L → H	10th tune
H	L	H	L	L → H	11th tune
H	L	H	H	L → H	12th tune
H	H	L	L	L → H	13th tune
H	H	L	H	L → H	14th tune
H	H	H	L	L → H	15th tune
H	H	H	H	L → H	16th tune

1. H = VDD level, L = VSS level

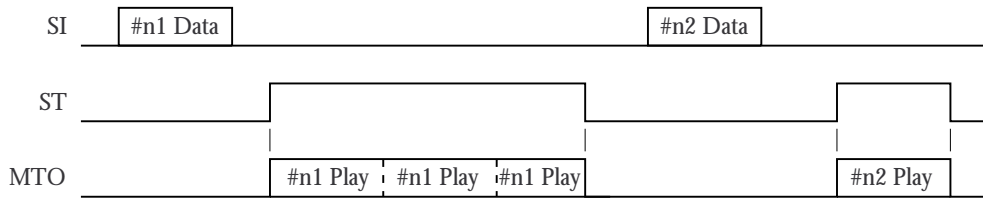

\*: Tune plays repeatedly when ST is HIGH, and stops immediately when ST goes LOW.

### Playback timing diagrams

#### Playback start

Playback starts  $128 \pm 1$  SCK clock cycles after ST goes HIGH.

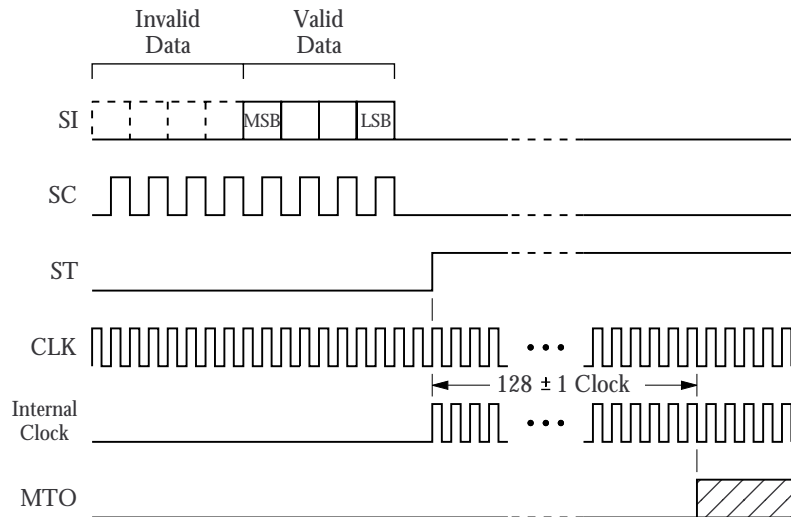

#### Playback stop

Playback stops immediately when ST goes LOW. The IC internal clock also stops, regardless of whether or not there is a clock input signal on pin CLK.

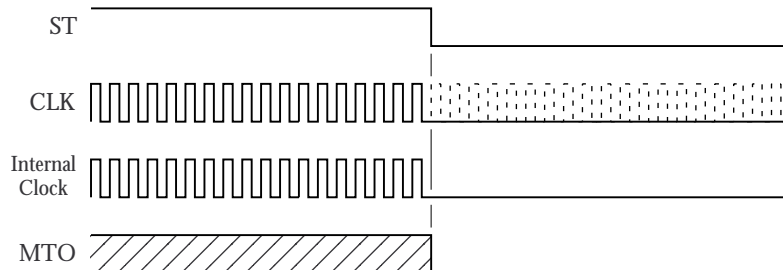

## Musical Specifications

### Maximum program steps

The mask for the built-in ROM can be programmed with up to a maximum of 512 steps, where each step represents either a note (sound pitch and length) or a rest.

### Note length (including rests)

Eight rhythm values for notes (rests) can be programmed. Also, 2 or more notes can be programmed as tied notes using a tie.

	0	1	2	3	4	5	6	7
Note								
Rest								

### Pitch and scale

The SM1124 performs uniform interval length processing to reduce the error at high pitches. This maintains the relative phase when the frequency varies from the input value.

The pitch varies with the external reference clock frequency, as shown in the frequency on the following page.

The frequency variation from the input frequency is the sum of the relative error, shown in the frequency table, plus the pitch error.

(Ex) 38.4 kHz system, A4 note

Relative error: 8.99 cent

Pitch error: -3.58 cent

Total: +5.41 cent

Error calculation method:

$$\begin{aligned}
 1200 \times \log_2 \frac{\text{Output frequency}}{\text{Reference frequency}} &= 1200 \times \frac{\log_{10} \frac{\text{Output frequency}}{\text{Reference frequency}}}{\log_{10} 2} \\
 &\approx 3986.3 \times \log_{10} \frac{\text{Output frequency}}{\text{Reference frequency}} \\
 &\approx 3986.3 \times \log_{10} \frac{441.379}{440.000} \\
 &\approx 5.41 \text{ cent}
 \end{aligned}$$

## SM1124 Series

### Frequency tables

Number	Frequency divider	Relative error (cent)	32.768 kHz system		37.5 kHz system		38.4 kHz system		48 kHz system	
			Pitch	Frequency (Hz)	Pitch	Frequency (Hz)	Pitch	Frequency (Hz)	Pitch	Frequency (Hz)
1	247	2.49	C3	132.664	D#3	151.822	D#3	155.466	G3	194.332
2	233	3.50	C#3	140.635	E3	160.944	E3	164.807	G#3	206.009
3	220	2.89	D3	148.945	F3	170.455	F3	174.545	A3	218.182
4	208	0.00	D#3	157.538	F#3	180.288	F#3	184.615	A#3	230.769
5	196	2.88	E3	167.184	G3	191.327	G3	195.918	B3	244.898
6	185	2.87	F3	177.124	G#3	202.703	G#3	207.568	C4	259.459
7	175	-0.93	F#3	187.246	A3	214.286	A3	219.429	C#4	274.286
8	165	0.94	G3	198.594	A#3	227.273	A#3	232.727	D4	290.909
9	156	-1.96	G#3	210.051	B3	240.385	B3	246.154	D#4	307.692
10	147	0.93	A3	222.912	C4	255.102	C4	261.224	E4	326.531
11	139	-2.21	A#3	235.741	C#4	269.784	C#4	276.259	F4	345.324
12	131	0.42	B3	250.137	D4	286.260	D4	293.130	F#4	366.412
13	124	-4.50	C4	264.258	D#4	302.419	D#4	309.677	G4	387.097
14	117	-3.91	C#4	280.068	E4	320.513	E4	328.205	G#4	410.256
15	110	2.89	D4	297.891	F4	340.909	F4	349.091	A4	436.364
16	104	0.00	D#4	315.077	F#4	360.577	F#4	369.231	A#4	461.538
17	98	2.88	E4	334.367	G4	382.653	G4	391.837	B4	489.796
18	93	-6.46	F4	352.344	G#4	403.226	G#4	412.903	C5	516.129
19	87	8.99	F#4	376.644	A4	431.034	A4	441.379	C#5	551.724
20	83	-9.52	G4	394.795	A#4	451.807	A#4	462.651	D5	578.313
21	78	-1.96	G#4	420.103	B4	480.769	B4	492.308	D#5	615.385
22	74	-10.81	A4	442.811	C5	506.757	C5	518.919	E5	648.649
23	69	10.29	A#4	474.899	C#5	543.478	C#5	556.522	F5	695.652
24	66	-12.74	B4	496.485	D5	568.182	D5	581.818	F#5	727.273
25	62	-4.50	C5	528.516	D#5	604.839	D#5	619.355	G5	774.194
26	58	10.95	C#5	564.966	E5	646.552	E5	662.069	G#5	827.586
27	55	2.89	D5	595.782	F5	681.818	F5	698.182	A5	872.727
28	52	0.00	D#5	630.154	F#5	721.154	F#5	738.462	A#5	923.077
29	49	2.88	E5	668.735	G5	765.306	G5	783.673	B5	979.592
30	46	12.26	F5	712.348	G#5	815.217	G#5	834.783	C6	1043.478
31	44	-10.79	F#5	744.727	A5	852.273	A5	872.727	C#6	1090.909
32	41	11.47	G5	799.220	A#5	914.634	A#5	936.585	D6	1170.732
33	39	-1.96	G#5	840.205	B5	961.538	B5	984.615	D#6	1230.769
34	37	-10.81	A5	885.622	C6	1013.514	C6	1037.838	E6	1297.297
35	35	-14.62	A#5	936.229	C#6	1071.429	C#6	1097.143	F6	1371.429
36	33	-12.74	B5	992.970	D6	1136.364	D6	1163.636	F#6	1454.545
37	31	-4.50	C6	1057.032	D#6	1209.677	D#6	1238.710	G6	1548.387
38	29	10.95	C#6	1129.931	E6	1293.103	E6	1324.138	G#6	1655.172
39	28	-28.30	D6	1170.286	F6	1339.286	F6	1371.429	A6	1714.286
40	26	0.00	D#6	1260.308	F#6	1442.308	F#6	1476.923	A#6	1846.154
41	25	-32.09	E6	1310.720	G6	1500.000	G6	1536.000	B6	1920.000
42	23	12.26	F6	1424.696	G#6	1630.435	G#6	1669.565	C7	2086.957
43	22	-10.79	F#6	1489.455	A6	1704.545	A6	1745.455	C#7	2181.818
44	21	-30.25	G6	1560.381	A#6	1785.714	A#6	1828.571	D7	2285.714
			+21.84 cent pitch error		-44.64 cent pitch error		-3.58 cent pitch error		-17.26 cent pitch error	

Pitch	Reference frequency
C3	130.8128
C#3	138.5913
D3	146.8325
D#3	155.5635
E3	164.8138
F3	174.6143
F#3	184.9973
G3	195.9978
G#3	207.6525
A3	220.0000
A#3	233.0820
B3	246.9418
C4	261.6255
C#4	277.1825
D4	293.6650
D#4	311.1270
E4	329.6275
F4	349.2285
F#4	369.9945
G4	391.9955
G#4	415.3050
A4	440.0000
A#4	466.1640
B4	493.8835
C5	523.2510
C#5	554.3650
D5	587.3300
D#5	622.2540
E5	659.2550
F5	698.4570
F#5	739.9890
G5	783.9910
G#5	830.6100
A5	880.0000
A#5	932.3280
B5	987.7670
C6	1046.5020
C#6	1108.7300
D6	1174.6600
D#6	1244.5080
E6	1318.5100
F6	1396.9140
F#6	1479.9780
G6	1567.9820
G#6	1661.2200
A6	1760.0000
A#6	1864.6560
B6	1975.5340
C7	2093.0040
C#7	2217.4600
D7	2349.3200

(Note) A4 is the following note.

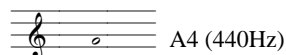



## Tempo

There are 29 tempos that can be selected for each tune. The tempo varies with the external reference frequency.

### Tempo table

ROM		32.768 kHz system		37.5 kHz system		38.4 kHz system		48 kHz system	
Code	Frequency divider	Temp	♪ =	Temp	♪ =	Temp	♪ =	Temp	♪ =
03	4	Prestissimo	320.0	Prestissimo	366.2	Prestissimo	375.0	Prestissimo	468.8
04	5		256.0		293.0		300.0		375.0
05	6		213.3		244.1		250.0		312.5
06	7	Presto	182.9		209.3		214.3		267.9
07	8	Allegro	160.0	Presto	183.1	Presto	187.5		234.4
08	9		142.2	Allegro	162.8	Allegro	166.7		208.3
09	10		128.0		146.5		150.0	Presto	187.5
0A	11	Moderato	116.4		133.2		136.4		170.5
0B	12		106.7		122.1		125.0	Allegro	156.3
0C	13	Andante	98.5	Moderato	112.7	Moderato	115.4		144.2
0D	14		91.4		104.6		107.1	133.9	
0E	15		85.3	Andante	97.7	Andante	100.0	125.0	
0F	16		80.0		91.6		93.8	Moderato	117.2
10	17	75.3	86.2		88.2		110.3		
11	18	Adagio	71.1		81.4		83.3	Andante	104.2
12	19		67.4		77.1		78.9		98.7
13	20	Larghetto	64.0	Adagio	73.2	Adagio	75.0		93.8
14	21		61.0		69.8		71.4		89.3
15	22		58.2		66.6				68.2
16	23	Largo	55.7	Larghetto	63.7	Larghetto	65.2		81.5
17	24		53.3		61.0		62.5	78.1	
18	25		51.2	Largo	58.6	Largo	60.0	Adagio	75.0
19	26		49.2		56.3		57.7		72.1
1A	27		47.4		54.3		55.6		69.4
1B	28		45.7		52.3		53.6	67.0	
1C	29		44.1		50.5		51.7	Larghetto	64.7
1D	30		42.7		48.8		50.0		62.5
1E	31		41.3	47.3	48.4	60.5			
1F	32			40.0		45.8		46.9	Largo

Quarter note (♩) length =  $1536 \times \text{tempo counter frequency divider} \div \text{CLK frequency}$

(Ex) Tempo code = 1F (divider = 32), CLK frequency = 32.768 kHz

$1536 \times 32 \div 32768 = 1.5$  (seconds)

## TYPICAL APPLICATION

### Speaker drive with switching circuit

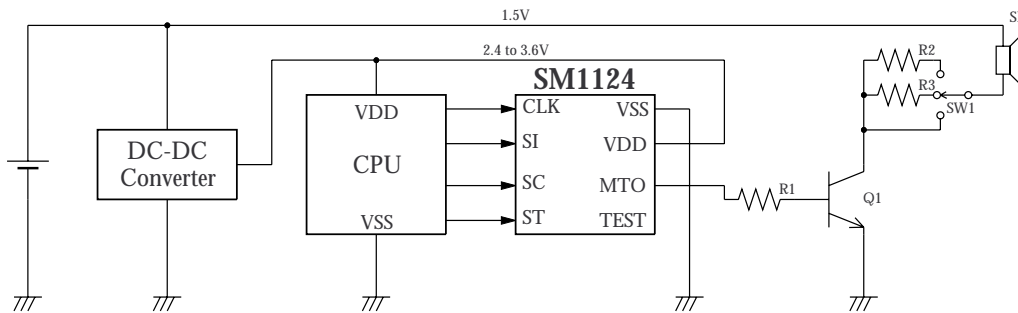

For example

Q1: hfe 100 MIN SP: Impedance 16Ω MIN

R1: 1.2kΩ

R2, R3: to be decided by sound volume

### Speaker drive with Linear amplifier

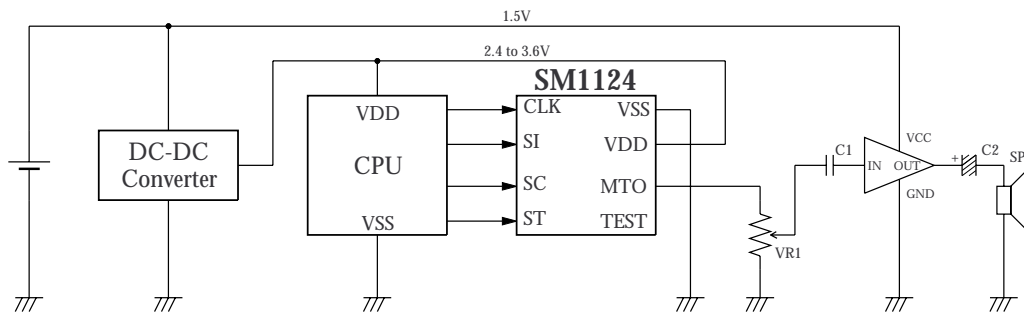

For example

VR1: 10kΩ MIN

(As the output impedance of MTO terminal is up to 1kΩ MAX, the value above is given under the condition that output shall be over 90% of supply voltage amplitude. If it is set below 10kΩ, output amplitude becomes smaller.)

C1: to be decided by Input impedance of amplifier.

C2, SP: to be decided by Output impedance of amplifier.

NIPPON PRECISION CIRCUITS INC. reserves the right to make changes to the products described in this data sheet in order to improve the design or performance and to supply the best possible products. Nippon Precision Circuits Inc. assumes no responsibility for the use of any circuits shown in this data sheet, conveys no license under any patent or other rights, and makes no claim that the circuits are free from patent infringement. Applications for any devices shown in this data sheet are for illustration only and Nippon Precision Circuits Inc. makes no claim or warranty that such applications will be suitable for the use specified without further testing or modification. The products described in this data sheet are not intended to use for the apparatus which influence human lives due to the failure or malfunction of the products. Customers are requested to comply with applicable laws and regulations in effect now and hereinafter, including compliance with export controls on the distribution or dissemination of the products. Customers shall not export, directly or indirectly, any products without first obtaining required licenses and approvals from appropriate government agencies.

**NPC**  
NIPPON PRECISION CIRCUITS INC.

NIPPON PRECISION CIRCUITS INC.

4-3, Fukuzumi 2-chome  
Koto-ku, Tokyo 135-8430, Japan  
Telephone: 03-3642-6661  
Facsimile: 03-3642-6698

NC9503AE 1996.01