

404-974

GEC PLESSEY
SEMICONDUCTORS

SL6270 GAIN CONTROLLED MICROPHONE PREAMPLIFIER/VOGAD

The SL6270 is a silicon integrated circuit combining the functions of audio amplifier and voice operated gain adjusting device (VOGAD).

It is designed to accept signals from a low sensitivity microphone and to provide an essentially constant output signal for a 50dB range of input. The dynamic range, attack and decay times are controlled by external components.

FEATURES

- Constant Output Signal
- Fast Attack
- Low Power Consumption
- Simple Circuitry

APPLICATIONS

- Audio AGC Systems
- Transmitter Overmodulation Protection
- Tape Recorders

QUICK REFERENCE DATA

- Supply Voltage: 4.5V to 10V
- Voltage Gain: 52dB

ABSOLUTE MAXIMUM RATINGS

Supply voltage: 12V
Storage temperature: -55°C to +125°C

ORDERING INFORMATION

SL6270 C CM
SL6270 C DP
SL6270 CB CM
SL6270 NA MP

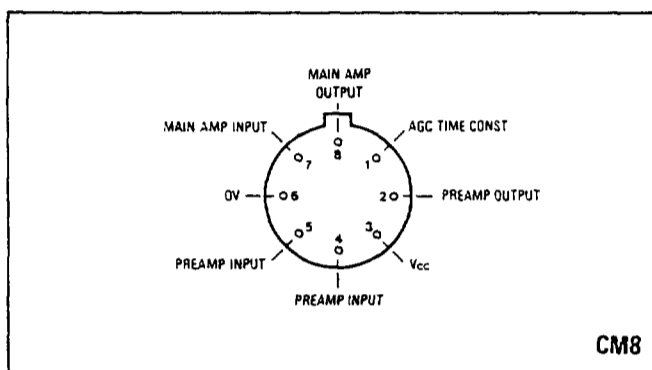

Fig. 1 Pin connections, SL6270 - CM (bottom view)

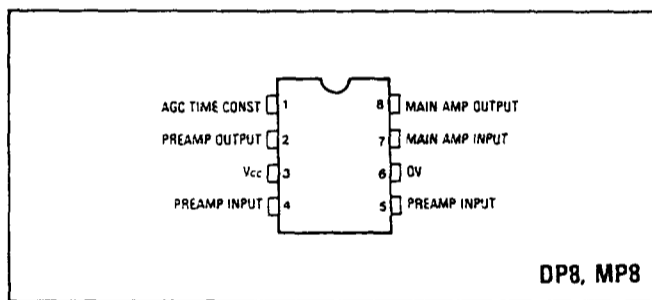

Fig. 2 Pin connections, SL6270 - DP (top view)

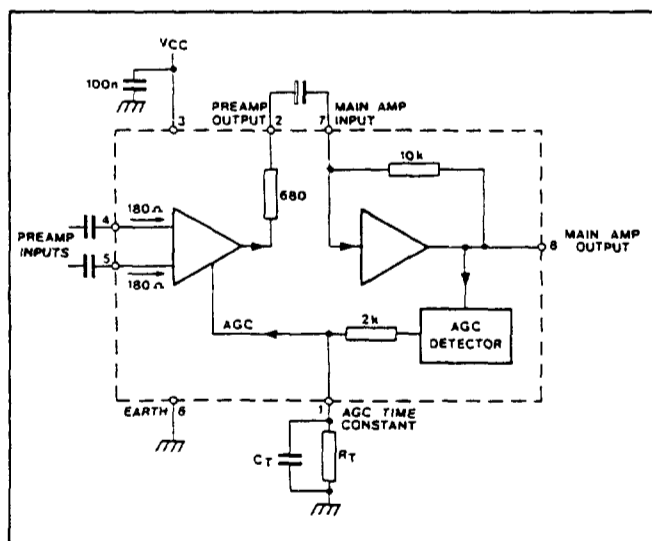

Fig. 3 SL6270 block diagram

ELECTRICAL CHARACTERISTICS

Test conditions (unless otherwise stated):

Supply voltage V_{CC} : 6V

Input signal frequency: 1kHz

Ambient temperature: -30°C to $+85^{\circ}\text{C}$

Test circuit shown in Fig. 4

Characteristic	Value			Units	Conditions
	Min.	Typ.	Max.		
Supply current		5	10	mA	
Input impedance		150		Ω	Pin 4 or 5
Differential input impedance		300		Ω	
Voltage gain	40	52		dB	$72\mu\text{V}$ rms input pin 4
Output level	55	90	140	mV rms	4mV rms input pin 4
THD		2	5	%	90mV rms input pin 4
Equivalent noise input voltage		1		μV	300Ω source, 400Hz to 25kHz bandwidth

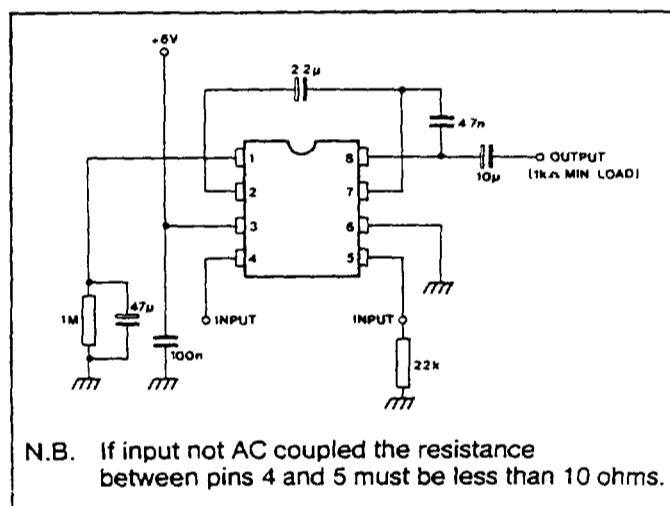

Fig.4 SL6270 test and application circuit

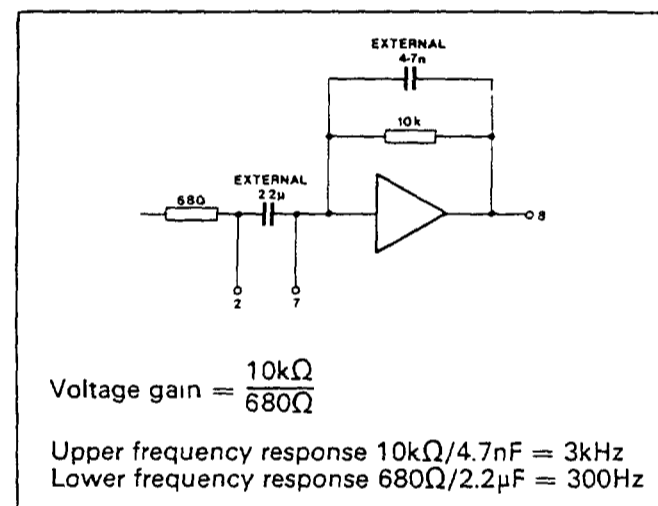

Fig.5 SL6270 frequency response

APPLICATION NOTES

Voltage gain

The input to the SL6270 may be single ended or differential but must be capacitor coupled. In the single-ended mode the signal can be applied to either input, the remaining input being decoupled to ground. Input signals of less than a few hundred microvolts rms are amplified normally but as the input level is increased the AGC begins to take effect and the output is held almost constant at 90mV rms over an input range of 50dB.

The dynamic range and sensitivity can be reduced by reducing the main amplifier voltage gain. The connection of a 1k resistor between pins 7 and 8 will reduce both by approximately 20dB. Values less than 680Ω are not advised.

Frequency response

The low frequency response of the SL6270 is determined by the input, output and coupling capacitors. Normally the coupling capacitor between pins 2 and 7 is chosen to give a -3dB point at 300Hz, corresponding to $2.2\mu\text{F}$, and the other capacitors are chosen to give a response to 100Hz or less

The SL6270 has an open loop upper frequency response of a few MHz and a capacitor should be connected between pins 7 and 8 to give the required bandwidth.

Attack and delay times

Normally the SL6270 is required to respond quickly by holding the output level almost constant as the input is increased. This 'attack time', the time taken for the output to return to within 10% of the original level following a 20dB increase in input level, will be approximately 20ms with the circuit of Fig.4. It is determined by the value of the capacitor connected between pin 1 and ground and can be calculated approximately from the formula:

$$\text{Attack time} = 0.4\text{ms}/\mu\text{F}$$

The decay time is determined by the discharge rate of the capacitor and the recommended circuit gives a decay rate of 20dB/second. Other values of resistance between pin 1 and ground can be used to obtain different results.

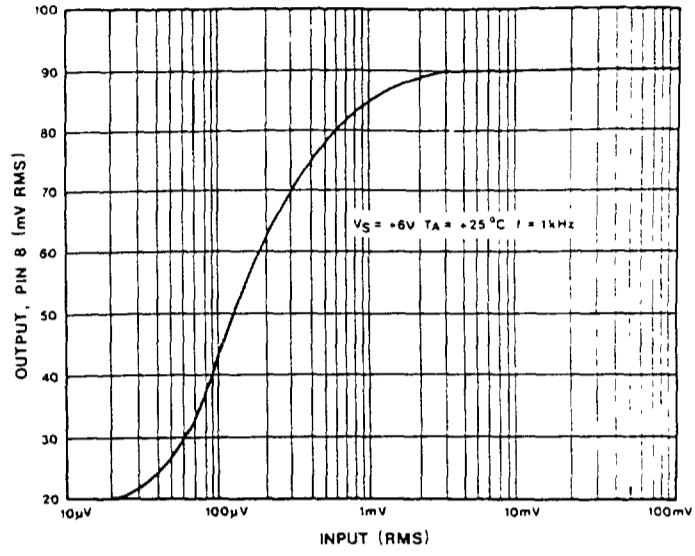

Fig 6 Voltage gain (single ended input) (typical)

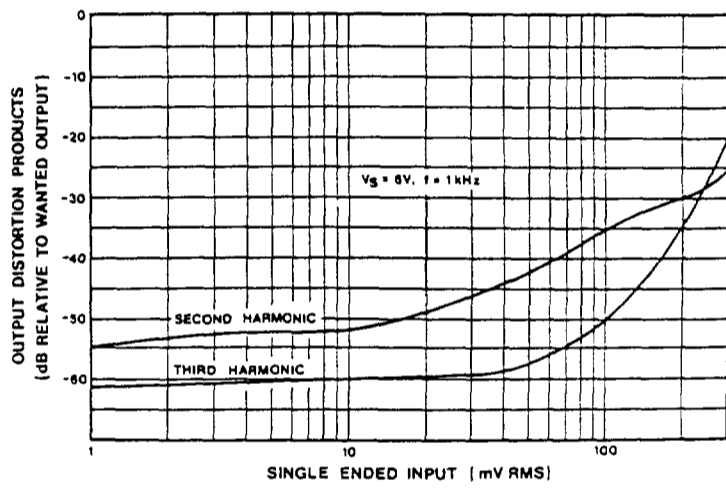

Fig 7 Overload characteristics (typical)

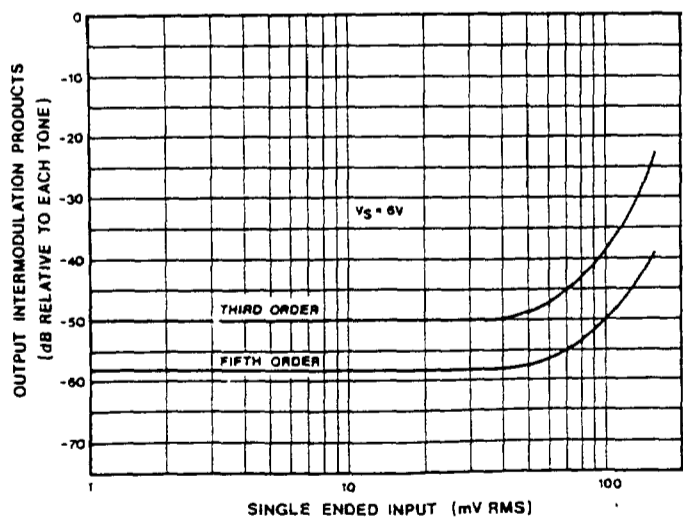

Fig 8 Typical Intermodulation distortion (155 and 185kHz tones)

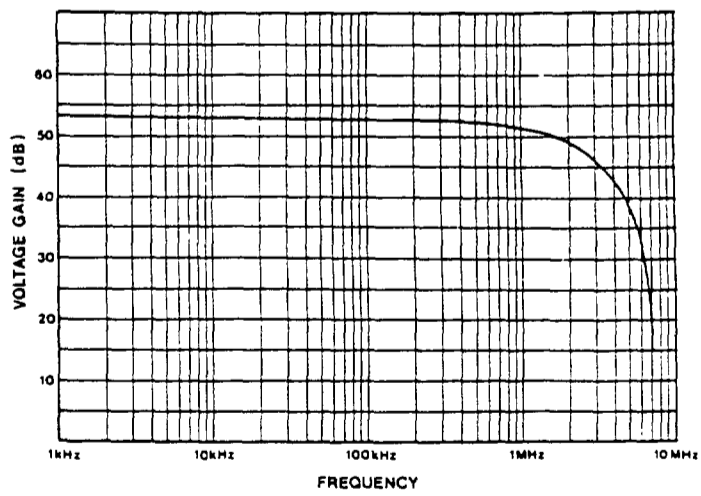

Fig 9 Open loop frequency response (typical)