

NE/SA/SE558 Quad Timer

Product Specification

Linear Products

DESCRIPTION

The 558 Quad Timers are monolithic timing devices which can be used to produce four independent timing functions. The 558 output sinks current. These highly stable, general purpose controllers can be used in a monostable mode to produce accurate time delays; from microseconds to hours. In the time delay mode of operation, the time is precisely controlled by one external resistor and one capacitor. A stable operation can be achieved by using two of the four timer sections.

The four timer sections in the 558 are edge-triggered; therefore, when connected in tandem for sequential timing applications, no coupling capacitors are required. Output current capability of 100mA is provided in both devices.

FEATURES

- 100mA output current per section
- Edge-triggered (no coupling capacitor)
- Output independent of trigger conditions
- Wide supply voltage range 4.5V to 18V
- Timer intervals from microseconds to hours
- Time period equals RC
- Military qualifications pending

APPLICATIONS

- Sequential timing
- Time delay generation
- Precision timing
- Industrial controls
- Quad one-shot

PIN CONFIGURATION

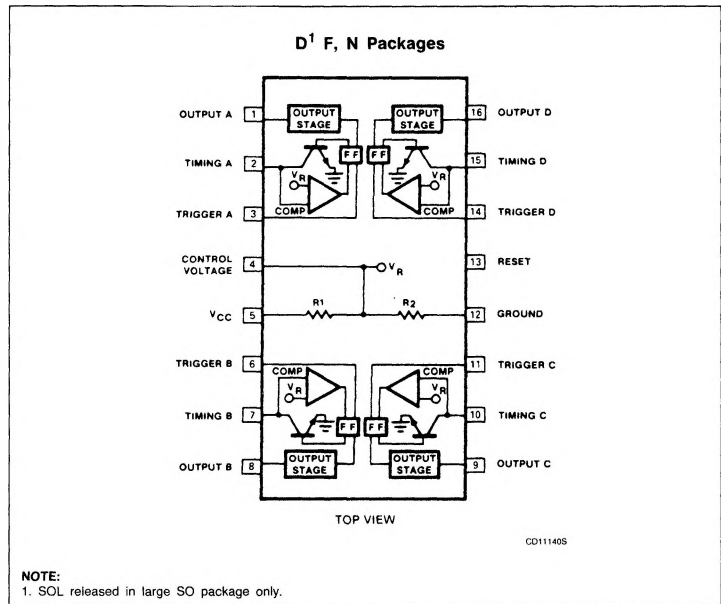

ORDERING INFORMATION

DESCRIPTION	TEMPERATURE RANGE	ORDER CODE
16-Pin Plastic SOL	0 to +70°C	NE558D
16-Pin Cerdip	0 to +70°C	NE558F
16-Pin Plastic DIP	0 to +70°C	NE558N
16-Pin Cerdip	-40°C to +85°C	SA558F
16-Pin Plastic DIP	-40°C to +85°C	SA558N
16-Pin Cerdip	-55°C to +125°C	SE558F
16-Pin Plastic DIP	-55°C to +125°C	SE558N

Quad Timer

NE/SA/SE558

ABSOLUTE MAXIMUM RATINGS

SYMBOL	PARAMETER	RATING	UNIT
V _{CC}	Supply voltage NE/SA558 SE558	+16	V
		+18	V
P _D	Maximum power dissipation T _A = 25°C ambient (still-air) ¹ F package N package D package	1190	mW
		1450	mW
		1090	mW
T _A	Operating ambient temperature range NE558 SA558 SE558	0 to +70	°C
		-40 to +85	°C
		-55 to +125	°C
T _{STG}	Storage temperature range	-65 to +150	°C
T _{SOLD}	Lead soldering temperature (10sec max)	+300	°C

NOTE:

- Derate above 25°C, at the following rates:
F package at 9.5mW/°C
N package at 11.6mW/°C
D package at 8.7mW/°C

DC AND AC ELECTRICAL CHARACTERISTICS T_A = 25°C, V_{CC} = +5V to +15V, unless otherwise specified.

SYMBOL	PARAMETER	TEST CONDITIONS	SE558			NE/SA558			UNIT
			Min	Typ	Max	Min	Typ	Max	
V _{CC}	Supply voltage		4.5		18	4.5		16	V
I _{CC}	Supply current	V _{CC} = Reset = 15V		16	32		16	36	mA
t _A	Timing accuracy (t = RC)	R = 2kΩ to 100kΩ, C = 1μF							
Δt _A /ΔT	Initial accuracy			± 1.0	3		± 2	5	%
Δt _A /ΔV _S	Drift with temperature			30	100		30	150	ppm/°C
	Drift with supply voltage			0.1	0.9		0.1	0.9	%/V
V _{TRIG}	Trigger voltage ¹	V _{CC} = 15V	0.8		2.4	0.8		2.4	V
I _{TRIG}	Trigger current	Trigger = 0V		5	30		5	100	μA
V _{RESET}	Reset voltage ²		0.8		2.4	0.8		2.4	V
I _{RESET}	Reset current	Reset		50	300		50	500	μA
V _{TH}	Threshold voltage			0.63			0.63		× V _{CC}
	Threshold leakage			15			15		nA
V _{OUT}	Output voltage ³	I _L = 10mA I _L = 100mA		0.1	0.2		0.1	0.4	V
				0.7	1.5		1.0	2.0	V
	Output leakage			10	500		10	500	nA
t _{PD}	Propagation delay			1.0			1.0		μs
t _R	Rise time of output	I _L = 100mA		100			100		ns
t _F	Fall time of output	I _L = 100mA		100			100		ns

NOTES:

- The trigger functions only on the falling edge of the trigger pulse only after previously being high. After reset, the trigger must be brought high and then low to implement triggering.
- For reset below 0.8V, outputs set low and trigger inhibited. For reset above 2.4V, trigger enabled.
- The 558 output structure is open-collector which requires a pull-up resistor to V_{CC} to sink current. The output is normally low sinking current.

Quad Timer

NE/SA/SE558

558 EQUIVALENT CIRCUIT

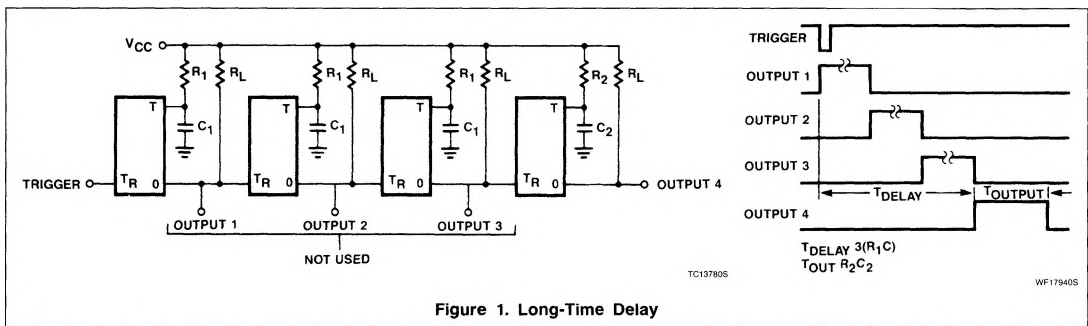
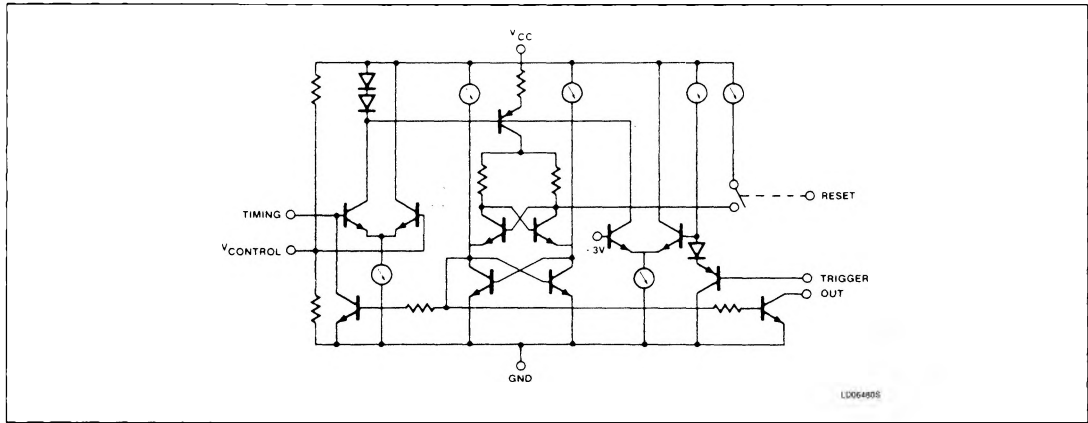
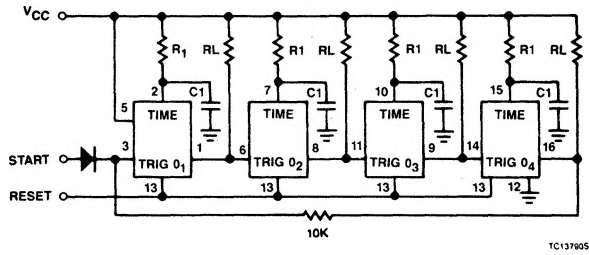

Figure 1. Long-Time Delay

Quad Timer

NE/SA/SE558



a. Ring Counter

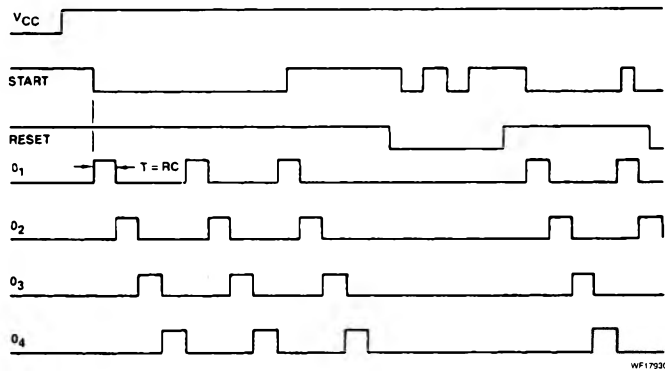

b. Expected Waveforms

Figure 2