



SINGLE LOW VOLTAGE C-MOS POWER AMPLIFIER

■ GENERAL DESCRIPTION

The NJU7081 is a single C-MOS Power Amplifier which is available to operate with single power supply and low voltage.

The NJU7081 realizes nearly full-swing output with low voltage operation (2.4V). An output voltage is kept more than $V_{DD}-0.3V$ or less than $V_{SS}+0.3V$ when output current is 40mA, therefore it is suitable for an ear-set and a small size speaker driver of the battery operated audio items, especially cellular phone.

■ PACKAGE OUTLINE



NJU7081M



NJU7081V



NJU7081R

■ FEATURES

- Single Power Supply
- Wide Operation Voltage Range (V_{DD} 2.4V ~ 5.5V)
- Nearly Full-Swing Output
($V_{SS}+0.3V \sim V_{DD}-0.3V$ at $I_{out} = \pm 40mA$)
- Low Distortion
(0.05% at $R_L = 38\Omega$, 1.0Vp-p)
- Low Operating Current
(1.5mA at $V_{DD} = 3V$)
- Stand-by Function
(1.0 μ A at $V_{DD} = 3V$)
- Package Outline -- DMP8 / SSOP8 / VSP8
- C-MOS Technology

■ PIN CONFIGURATION

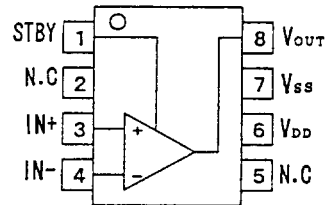

Note1) STBY terminal

"H" or "OPEN" : Stand-by operation

"L" : Normal operation

■ EQUIVALENT CIRCUIT

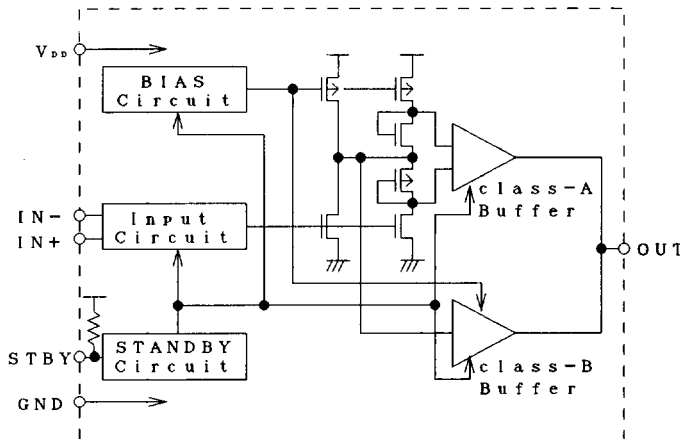



■ ABSOLUTE MAXIMUM RATINGS

(Ta=25°C)

PARAMETER	SYMBOL	RATINGS	UNIT
Supply Voltage	V _{DD}	7	V
Input Voltage	V _{ID}	V _{SS} -0.3 ~ V _{DD} +0.3	V
Power Dissipation	P _D	300	mW
Operating Temperature	T _{opr}	-25 ~ +75	°C
Storage Temperature	T _{stg}	-40 ~ +125	°C

■ ELECTRICAL CHARACTERISTICS 1

PARAMETER	SYMBOL	CONDITIONS	MIN	TYP	MAX	UNIT
Operating Voltage Range	V _{DD}		2.4		5.5	V

 ■ ELECTRICAL CHARACTERISTICS 2 (V_{DD}=3V)

 (Ta=25°C, V_{DD}=3V, V_{SS}=0V, f=1kHz)

PARAMETER	SYMBOL	CONDITIONS	MIN	TYP	MAX	UNIT
Operating Current	I _{DD}	No Load Condition : Voltage Follower V _O =1.5V		1.5	2	mA
Standby Current	I _{STB}				1.0	μA
Standby terminal Current	I _{PIIN}	V _{DD} =3V, V _{stb} =0V		10		μA
Standby terminal Input Voltage	V _{SIH}		0.8V _{DD}			V
	V _{SIL}				0.2V _{DD}	
Input Offset Voltage	V _{IO}		-10		10	mV
Input Offset Current	I _{IO}			10		pA
Input Bias Current	I _{IB}			10		pA
Input Resistor	R _{IN}			10 ¹¹		Ω
Input Common Mode Voltage Range	V _{ICM}		0.2~2			V
Maximum Output Voltage Range	V _{OM}	I _{out} =40mA	2.6	2.7		V
		I _{out} =-40mA		0.3	0.4	
Maximum Output Current	I _{OM}	(D+N)/S<0.1% Source		30		mA
		(D+N)/S<0.1% Sink		-30		
Large-Signal Voltage gain	A _v		55			dB
Common Mode Rejection ratio	CMRR	V _{ICM} =0.2~2.0V	53			dB
Supply Voltage Rejection ratio	PSRR	V _{DD} =2.7~3.3V	55			dB
Total Harmonic Distortion	(D+N)/S	V _O =1.0V _{p-p} 0~10dB, 38Ω		0.05		%
Equivalent Input Noise Voltage	E _{nt}	IEC-A		3		μV _{rms}
Signal to Noise Ratio	S/N			110		dB
Unity Gain Bandwidth	F _t	C _L =10pF, OPEN LOOP		1.5		MHz
Slew Rate	SR	Unity Gain Turn Over, C _L =32pF R _L =2kΩ		1		V/μs

NOTE2) The NJU7081 should be operated gaining of triple or more for stable operation.

NOTE3) When the NJU7081 using no-current-load and low gain application (voltage follower, etc.), oscillation will be worst. In this case, the stray capacitance of the output terminal should be less than 100pF.

■ ELECTRICAL CHARACTERISTICS 3 ($V_{DD}=5V$)

 (Ta=25°C, $V_{DD}=5V$, $V_{SS}=0V$, f=1kHz)

PARAMETER	SYMBOL	CONDITIONS	MIN	TYP	MAX	UNIT
Operating Current	I_{DD}	No Load Condition : Voltage Follower $V_o=2.5V$		3	4	mA
Standby Current	I_{STB}				1	μA
Standby terminal Current	I_{PIN}	$V_{DD}=3V, V_{stb}=0V$		30		μA
Standby terminal Input Voltage	V_{SIH}		0.8 V_{DD}			V
	V_{SIL}				0.2 V_{DD}	
Input Offset Voltage	V_{IO}		-10		10	mV
Input Offset Current	I_{IO}			10		pA
Input Bias Current	I_{IB}			10		pA
Input Resistor	R_{IN}			10 ¹¹		Ω
Input Common Mode Voltage Range	V_{ICM}		0.4~4			V
Maximum Output Voltage Range	V_{OM}	$I_{out}=40mA$	4.6	4.7		V
		$I_{out}=-40mA$		0.3	0.4	
Maximum Output Current	I_{OM}	(D+N)/S<0.1% Source		30		mA
		(D+N)/S<0.1% Sink		-30		
Large-Signal Voltage gain	A_v		55			dB
Common Mode Rejection ration	CMRR	$V_{ICM}=0.4\sim4.0V$	53			dB
Supply Voltage Rejection ration	PSRR	$V_{DD}=4.5\sim5.5V$	55			dB
Total Harmonic Distortion	(D+N)/S	$V_o=1.0V_{p-p}$ 0~10dB, 38 Ω		0.05		%
Equivalent Input Noise Voltage	Ent	IEC-A		3		μV_{rms}
Signal to Noise Ratio	S/N			110		dB
Unity Gain Bandwidth	F_t	CL=10pF, OPEN LOOP		1.5		MHz
Slew Rate	SR	Unity Gain Turn Over, CL=32pF RL=2k Ω		1		V/ μs

NOTE4) The NJU7081 should be operated gaining of triple or more for stable operation.

NOTE5) When the NJU7081 using no-current-load and low gain application (voltage follower, etc.), oscillation will be worst. In this case, the stray capacitance of the output terminal should be less than 100pF.



■ APPLICATION CIRCUIT

