

FM IF IC FOR REMOTE KEYLESS ENTRY SYSTEM

■ GENERAL DESCRIPTION

The NJM2295A is FM IF IC for the remote keyless entry system (RKE). It includes almost all functions of IF blocks, from the 1st. Mixer to the wave shaving circuit.

Exclusively designed NJM2295A is suited not only for the RKE, but for other FM signal receivers.

■ PACKAGE OUTLINE

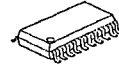

NJM2295AV

■ FEATURES

- Low Operating Current      5mA typ. at  $V^+=5V$
- Low Operating Voltage      +2.7V~7.0V
- Local Oscillation Frequency   50~350MHz
- Mixer Active Frequency      ~450MHz
- IF Frequency                  IF=10.7MHz
- 1st. Mixer Included
- RSSI Circuit Included
- FSK Wave Shaping Circuit
- Bipolar Technology
- Package Outline                SSOP20

4

■ BLOCK DIAGRAM

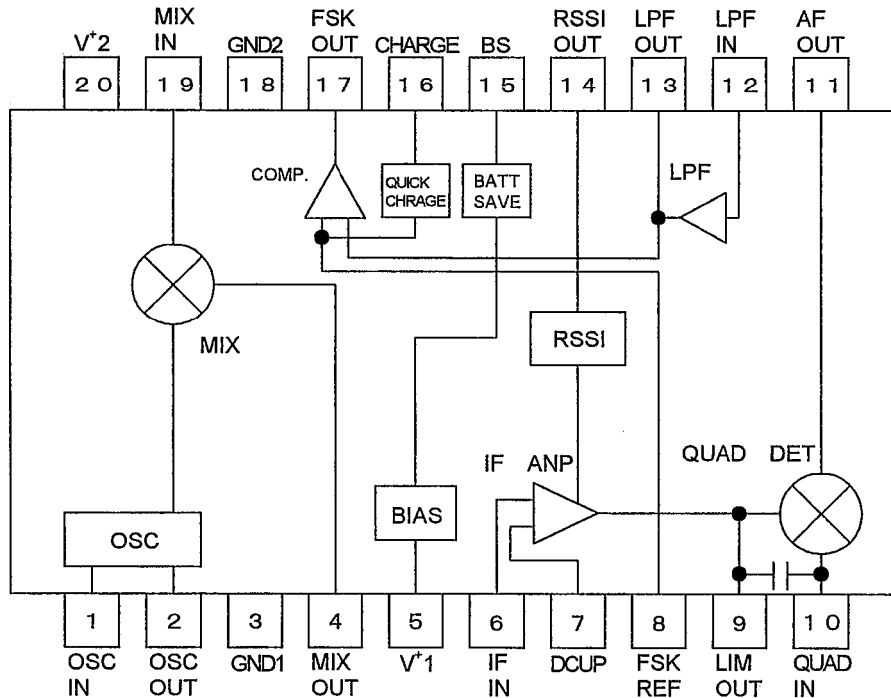

# NJM2295A

## ■ ABSOLUTE MAXIMUM RATINGS (Ta=25°C)

PARAMETER	SYMBOL	RATINGS	UNIT
Supply Voltage	V <sup>+</sup>	9.0	V
Power Dissipation	P <sub>D</sub>	300	mW
Operating Temperature Range	T <sub>opr</sub>	-40~+85	°C
Storage Temperature Range	T <sub>stg</sub>	-40~+125	°C

## ■ ELECTRICAL CHARACTERISTICS (V<sup>+</sup>=5.0V, Ta=25°C, f<sub>mod</sub>=1kHz, f<sub>mix</sub>=320MHz, f<sub>IF</sub>=10.7MHz, f<sub>dev</sub>=±10kHz)

PARAMETER	SYMBOL	TEST CONDITION	MIN.	TYP.	MAX.	UNIT
Supply Voltage	V <sup>+</sup>		2.7	—	7.0	V
No signal Operating Current	I <sub>ccq</sub>		—	5.0	7.5	mA
Battery saving Operating Current	I <sub>ccs</sub>		—	—	10	μA
Mixer Gain 1	G <sub>mix1</sub>	RL= No Connect.	13.5	18.5	22.5	dB
Mixer Gain 2	G <sub>mix2</sub>	320MHz Gain—450MHz Gain	—	1	3	dB
Mixer Sept Point	IP		—	103	—	dB μ VEMF
Mixer Input Resistance	R <sub>inM</sub>	f=320MHz	—	1	—	kΩ
Mixer Input Capacity	C <sub>inM</sub>	f=320MHz	—	2	—	pF
Mixer Output Resistance	R <sub>oM</sub>		—	330	—	Ω
IF amplifier Input Resistance	R <sub>inIF</sub>		—	330	—	Ω
Signal to Noise Ratio 1	S/N1	Mixer Input, V <sub>in</sub> =80dB μ VEMF	—	60	—	dB
Signal to Noise Ratio 2	S/N2	IF input, V <sub>in</sub> =80dB μ VEMF	—	60	—	dB
Signal to Noise Ratio 3	S/N3	IF input, V <sub>in</sub> =35dB μ VEMF	—	25	—	dB
-3dB limiting sensitivity	S <sub>lim</sub>	Mixer Input	—	22	27	dB μ VEMF
Demodulated Output Level	V <sub>od</sub>	IF input, V <sub>in</sub> =60dB μ VEMF	80	150	—	mV <sub>rms</sub>
AM Rejection Ratio	AMR	IF input, V <sub>in</sub> =80dB μ VEMF, AM=30%	—	50	—	dB
Duty ratio of Wave Shaped Output	DR	IF input, V <sub>in</sub> =60dB μ VEMF	40	50	60	%
RSSI Output Voltage 1	RSSI1	IF input V <sub>in</sub> =20dB μ VEMF	0.35	0.55	0.70	V
RSSI Output Voltage 2	RSSI2	IF input, V <sub>in</sub> =60dB μ VEMF	0.7	1.00	1.3	V
RSSI Output Voltage 3	RSSI3	IF input, V <sub>in</sub> =100dB μ VEMF	1.30	1.75	2.15	V
RSSI Output Resistance	RSSI <sub>R</sub>		—	48	—	kΩ
Quick charge/discharge current	I <sub>ch</sub>		35	70	120	μA
Low Level Output Voltage f FSK-OUT	V <sub>fskL</sub>	I <sub>L</sub> =100 μA	—	0.1	0.4	V
High Level Leak Current of FSK-OUT Terminal	I <sub>fskH</sub>		—	—	2	μA

4

APPLICATION CIRCUIT

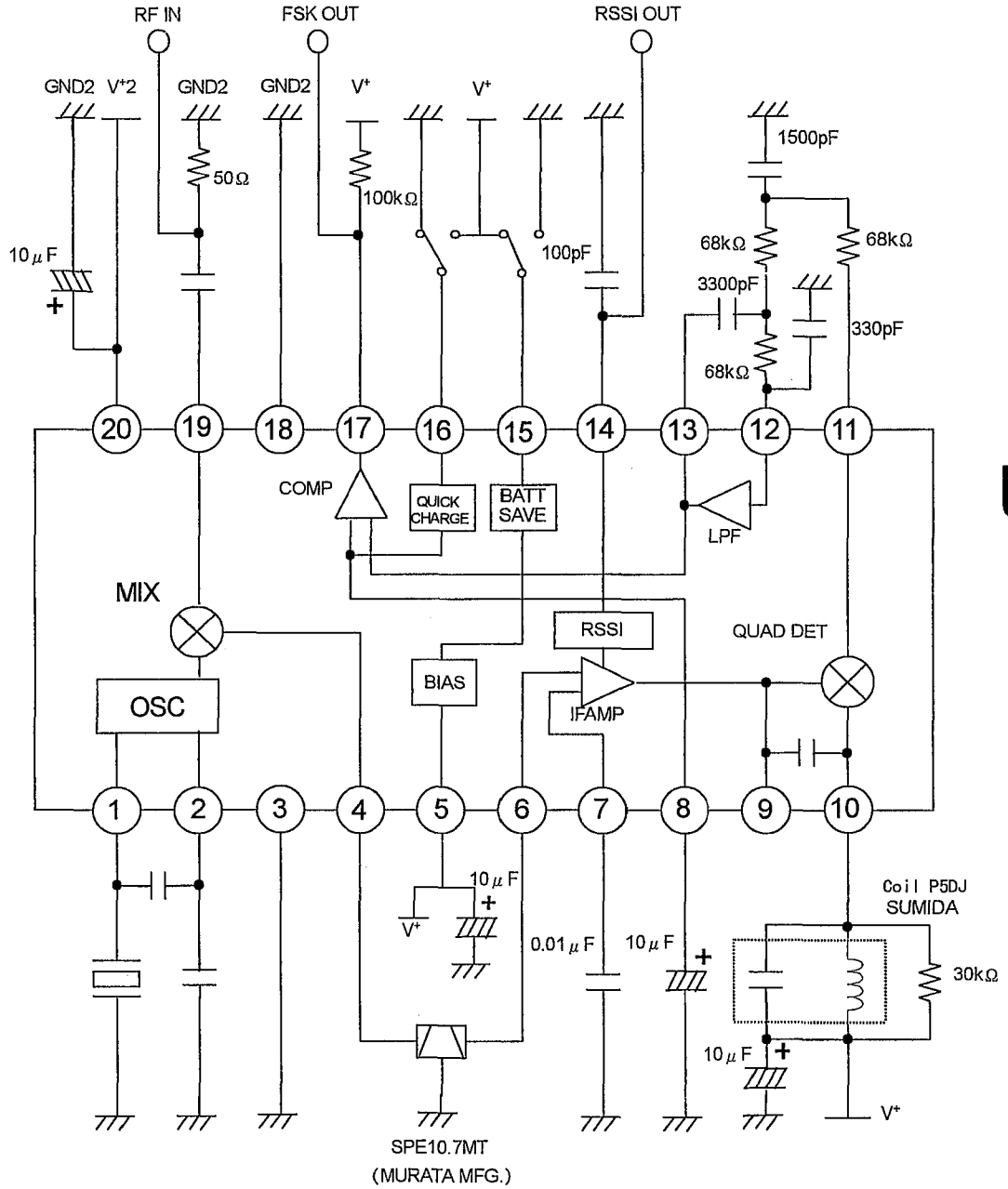

4

# NJM2295A

## ■ TERMINAL FUNCTION

PIN No.	SYMBOL	FUNCTION	EQUIVALENT CIRCUIT
1	OSC IN	SAW is oscillation input terminal.	
2	OSC OUT	Oscillation Output Terminal.	
19	MIX IN	Mixer input terminal. Input impedance : Parallel resistance : 1KΩ Parallel capacity : 2pF	
4	MIX OUT	Output terminal for mixer. Output resistance is 330 Ω at typical.	
6	IF IN	Limiter input terminal. Input resistance is 330 Ω at typical.	
7	DEC	Decoupling terminal for bias.	

4

■ TERMINAL FUNCTION

PIN No.	SYMBOL	FUNCTION	EQUIVALENT CIRCUIT
9	LIM OUT	Output terminal for limiter amplifier. Typical input impedance is 300 ohms.	
10	QUAD IN	Input terminal of a quadrature detection circuit. Connect with a ceramic discriminator.	
14	RSSI OUT	RSSI output terminal	
11	AF OUT	Demodulated signal output	
12	LPF IN	Input terminal of a low pass filter. This terminal is biased from the AF-OUT terminal (11pin) through an external RC filter.	

4

# NJM2295A

## ■ TERMINAL FUNCTION

PIN No.	SYMBOL	FUNCTION	EQUIVALENT CIRCUIT
13	LPF OUT	Output terminal of a low pass filter.	
8	FSK REF	Reference input terminal of a wave shaping comparator. Connected with an external capacitor.	
17	FSK OUT	Output terminal of a wave shaping circuit. The Wave shaped signal inverted for the LPF output comes out.	
15	BS	Control terminal of a battery saving circuit. H: This circuit is ON L: This circuit is OFF	
16	CHARGE	Control terminal of a quick charge / discharge circuit. H: This circuit is ON. L: This circuit is OFF.	
5	V*1	On and after IF supply voltage.	-
3	GND1	On and after IF ground.	-
20	V*2	Supply voltage for mixer and OSC.	-
18	GND2	Ground for mixer and OSC.	-

4

# NJM2295A

---

## MEMO

**[CAUTION]**

The specifications on this databook are only given for information, without any guarantee as regards either mistakes or omissions. The application circuits in this databook are described only to show representative usages of the product and not intended for the guarantee or permission of any right including the industrial rights.