

SYNCHRONOUS SEPARATOR WITH AFC

■ GENERAL DESCRIPTION

NJM2257 executes Horizontal and Vertical synchronous signal separation, and odd/even field signal detection, from composite video signals.

Built-in 1/2 fH Killer Function circuit can make stabilization of the Horizontal signal oscillation output during the Vertical period.

■ PACKAGE OUTLINE

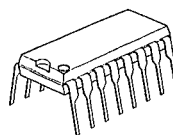

NJM22570

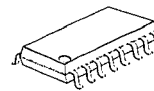

NJM2257M

■ FEATURES

- Operating Voltage (+4.5~+5.3V)
- Internal AFC circuit (Horizontal sync. signal.)
- Internal 1/2fH Killer Function
- AFC output Pulse Delay time is Adjustable
- Vertical synchronous pulse width is Adjustable
- Internal Field Discriminator Function
- Package Outline DIP16, DMP16
- Bipolar Technology

■ APPLICATION

- VTR, TV, AV components etc.

■ BLOCK DIAGRAM

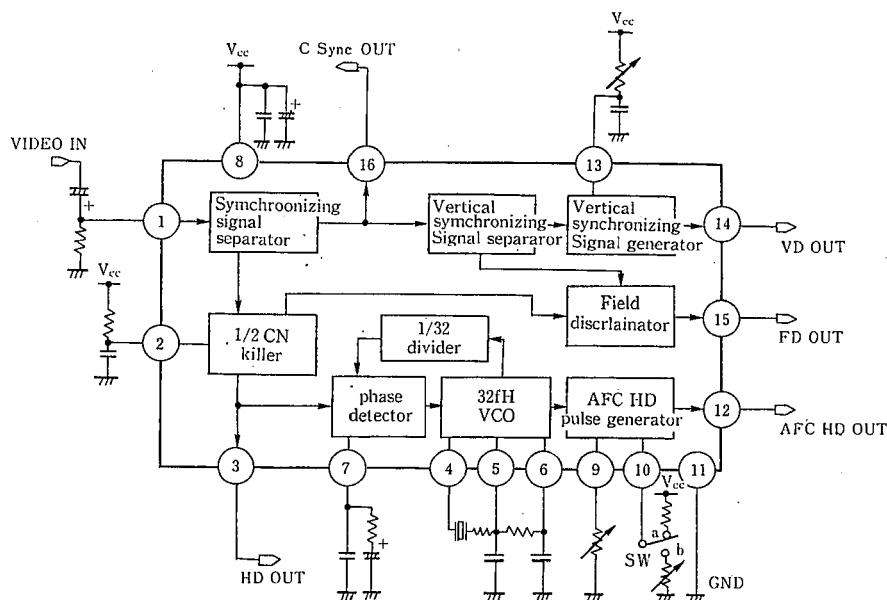

NJM2257

■ ABSOLUTE MAXIMUM RATINGS

(Ta=25°C)

PARAMETER	SYMBOL	RATINGS	UNIT
Supply Voltage	V*	+7	V
Power Dissipation	P _D	(DIP16) 500 (DMP16) 350	mW
Operating Temperature Range	T _{opr}	-20~+75	°C
Storage Temperature Range	T _{stg}	-40~+125	°C

■ ELECTRICAL CHARACTERISTICS

(V_{cc}=5V, Ta=25°C)

PARAMETER	SYMBOL	TEST CONDITION	MIN.	TYP.	MAX.	UNIT
Quiescent Current	I _Q		—	23.0	30.0	mA
AFC Free Run Frequency	f _{0H}		15.54	15.74	15.94	KHz
AFC HD pulse width	T _{AHW1}	SW=a	3.5	4.0	4.5	μS
	T _{AHW2}	SW=b	2.5	4.0	5.5	
AFC HD Delet Time	T _{AHD}		-1.0	0.5	2.0	μS
AFC Lock Range	Δf _{HL}		500	700	—	Hz
AFC Cap Charange	Δf _{HP}		400	600	—	Hz
AFC Output Voltage	H	V _{H_{AH}}	4.0	4.2	—	V
	L	V _{H_{AL}}	—	0	0.1	
Sync Sepa Sync. Separation Level	V _{HSR}		—	0.16	0.18	V
Sync Sepa Delay Time	T _{HCD}		0.05	0.20	0.35	μS
Sync Sepa Output Voltage	H	V _{H_{CH}}	4.0	4.2	—	V
	L	V _{H_{CL}}	—	0	0.1	
HD Output Palth Width	T _{HPW}		4.0	5.5	7.0	μS
HD Output Delay Time	T _{HPD}		0.35	0.6	0.8	μS
HD Output Voltage	H	V _{H_H}	4.0	4.2	—	V
	L	V _{H_L}	—	0	0.1	
V Sync Palth Width	T _{VW}		170	190	210	μS
V Sync Delay Time	T _{VD}		7.0	10.0	13.0	μS
V Sync Output Voltage	H	T _{V_H}	4.0	4.2	—	V
	L	V _{V_L}	—	0	0.1	
Field Distinction Delay Time	odd	T _{F_{OD}}	246	256	266	μS
	even	T _{F_{ED}}	216	226	236	
Field Distinction Output Voltage	odd	V _{F_{OR}}	4.0	4.2	—	V
	even	V _{F_{ER}}	—	0	0.1	

5

■ APPLICATION CIRCUIT

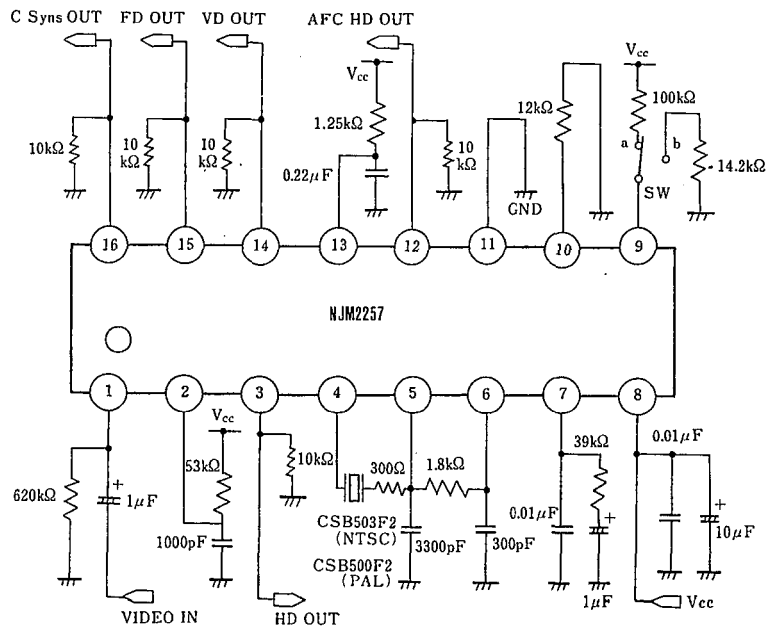

■ APPLICATION NOTES

It shows the characteristics by changing of the following resistor.

- The resistor between 9 Pin and GND
High resistance—AFC HD pulse is wide
Low resistance—AFC HD pulse is narrow
- The resistor between 9 Pin and V⁺
At the resistor is 100Ω. AFC HD Delay adjustment is off, and AFC HD output width is 4μs (typ.)
- The resistor between 9 Pin and GND is fundamentally 14.2 kΩ, because the purpose of this resistor is pulse width adjusts 4μs
- The resistor between 10 Pin and GND
High resistance—AFC HD Delay time gains
Low resistance—AFC HD Delay time loses
- The resistor between 13 Pin and GND
High resistance—Vsync pulse is wide
Low resistance—Vsync pulse is narrow
- The resistor joined 2 Pin
Please adjust the wide of following W is from 33 μs to 37 μs ($W = -(C \cdot R) \ln 0.5$)

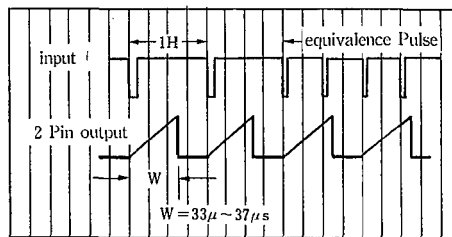
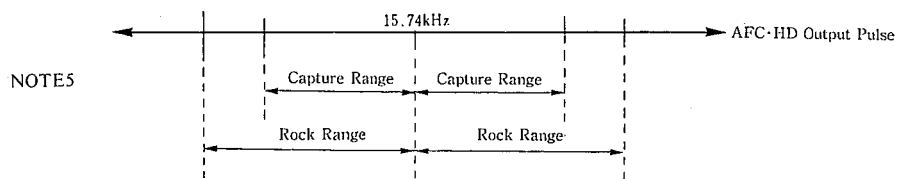
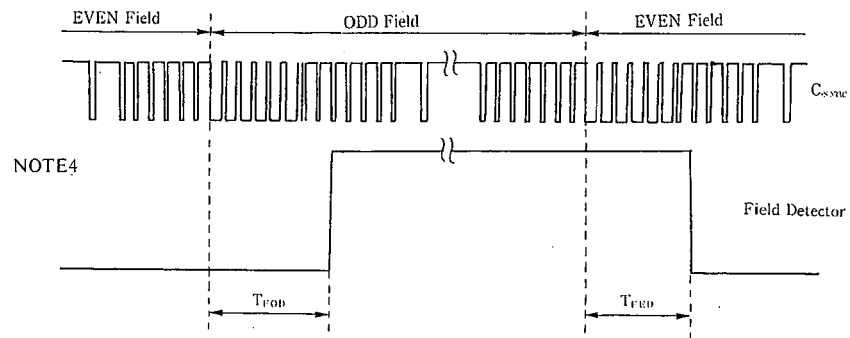
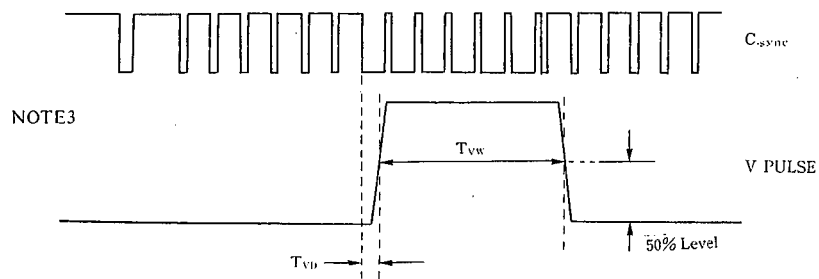
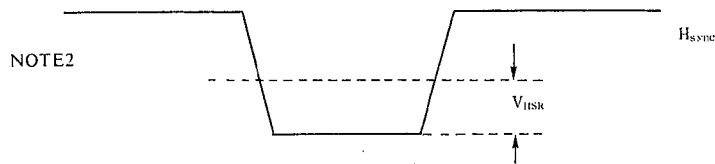
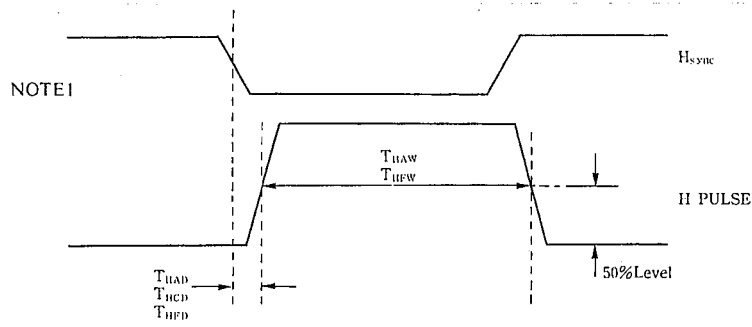

Fig 1 I/O PULSE



5

■ TERMINAL EXPLANATION

PIN NO.	PIN NAME	FUNCTION	INSIDE EQUIVALENT CIRCUIT
1	VIDEO-IN	Composit Video Signal Input	
2	MM-HT	HD & FD pulse are Controlled by setting mono multi	
3	HD-OUT	1/2 f _H Killer D Output	
4	VCO-OUT	VCO Output is to be given to Ceramic Oscillator	
5	VCO-FILTER 1	Decide the Volume to be transferred shall by decided of Ceramic Oscillator. (90°late)	

5

NJM2257

■ TERMINAL EXPLANATION

PIN NO.	PIN NAME	FUNCTION	INSIDE EQUIVALENT CIRCUIT
6	VCO-FILTER 2	Decide the Volume to be transferred shall by decided of Ceramic Oscillator. (90°late)	
7	L.P.F	L.P.F. of AFC	
8	V+	Supply Voltage	
9	VR-1	AFC-HD Output Can be adjusted by putting resistor between 9-GND (9 to V _{CC} no adjustment). The pulse width can be adjusted by making changeable of resistor (Adjusting mode)	
10	VR-2	AFC-HD Output delay adjustment by putting 10 pin resistor changeabl at 9 pin adjustment mode.	
11	GND	G raund	

5

■ TERMINAL EXPLANATION

PIN NO.	PIN NAME	FUNCTION	INSIDE EQUIVALENT CIRCUIT
12	AFC, HD-OUT	AFC-HD Output	
13	MM-VT	Pulse Width of Vsync-OUT is adjusted by setting mono multi time constant.	
14	Vsync-OUT	Vertical Synchronous Signal Output.	
15	FD-OUT discrimination	Field Distinction Signal Output.	
16	Csync-OUT	Synchronous Separation Output	

5

NJM2257

■ PIN FUNCTION

PIN NO	FUNCTION BLOCK	OPERATIONAL DESCRIPTION	NDTE
① Pin	Signal Input	Video Signal input	Sync tip clump
② Pin	HD pulse control	HD pulse and FD pulse control by time constant of CR	
③ Pin	HD pulse output	1/2 f_H killer HD pulse output	In a period of vertical synchronizing, a f_H is converted to f_H
④ Pin	AFC Oscillation	Oscillation of 503KHz by a ceramic oscillator, and divided by 32 to get down to 15.74KHz	
⑤ Pin			
⑥ Pin			
⑦ Pin	AFC control	Lag Lead filter for phase detection	
⑧ Pin	Vcc	Vcc	
⑨ Pin	AFC HD output Switch (AFC HD pulse width adjustment)	The case that R is connected between 9pin and Vcc...Fixed output The case that R is connected between 9pin and GND...Adjustable AFC HD Delay Mode	high Resistance → Wide pulse width Low Resistance → Narrow pulse width
⑩ Pin	AFC HD Delay adjustment	The case that R is connected between 9pin and GND...Adjustable AFC HD Delay output	High Resistance → Low Resistance →
⑪ Pin	GND	GND	
⑫ Pin	AFC HD output	AFC HD pulse output	Positive polarity
⑬ Pin	VD pulse width adjustment	VD pulse width control by time constant of CR	
⑭ Pin	VD output	Vertical synchronizing signal output	Positive polarity
⑮ Pin	FD output	Field discriminating signal output	odd field → High Output even field → Low Output
⑯ Pin	C Sync. output	Composite Sync Signal output	Positive polarity

5

NJM2257

MEMO

[CAUTION]

The specifications on this databook are only given for information, without any guarantee as regards either mistakes or omissions. The application circuits in this databook are described only to show representative usages of the product and not intended for the guarantee or permission of any right including the industrial rights.