

## VIDEO SUB-CARRIER SIGNAL TRIPLER

### ■ GENERAL DESCRIPTION

The NJM2238 is a tripler oscillator based on video subcarrier frequency using PLL circuit technique. The NJM2238 is suit to standard clock generator of CCD clock and on-screen display.

### ■ PACKAGE OUTLINE

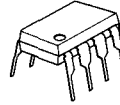

NJM2238D



NJM2238M

### ■ FEATURES

- Operating Voltage (+4.7V~+5.3V)
- Maximum Oscillator Frequency
- Tripler Output
- Package Outline DIP8,DMP8
- Bipolar Technology

### ■ APPLICATION

- VCR Video Camera AV-TV Video Disc Player

### ■ PIN CONFIGURATION

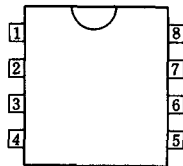

#### PIN FUNCTION

1.  $f_{sc}$  Input
2. Detection Filter
3. GND
4. Oscillator Output
5. Oscillator C
6.  $V^+$
7. Oscillator R
8. NC

■ BLOCK DIAGRAM & EXTERNAL COMPONENTS

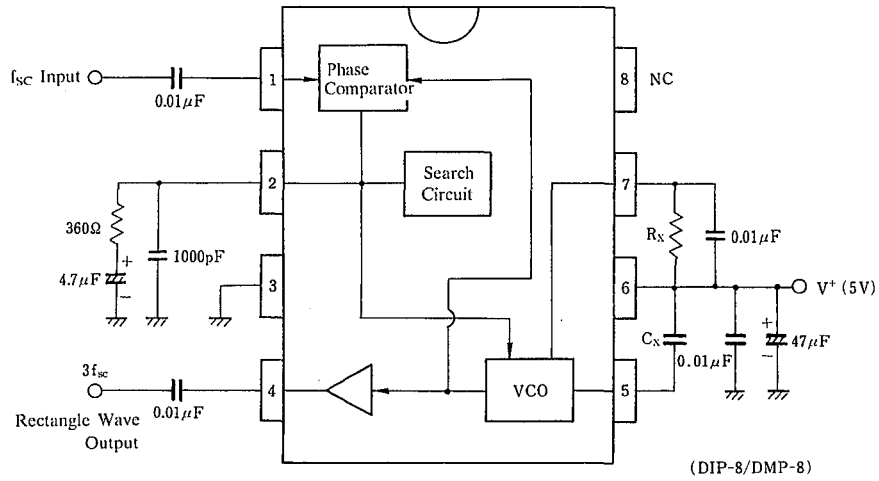

There is stray capacity assembled on PC board, and so select  $R_x$ ,  $C_x$  to the value which pin 2 voltage (search voltage at VCO locked) becomes about 2V.  $C_x > 5\text{pF}$ ,  $5.6\text{k}\Omega > R_x > 3.3\text{k}\Omega$

	NTSC	PAL
$C_x$	10 p	8 p
$R_x$	5.2k	4.4k



## ■ ABSOLUTE MAXIMUM RATINGS

(Ta=25°C)

PARAMETER	SYMBOL	RATINGS	UNIT
Supply Voltage	V*	8	V
Input Voltage	V <sub>IN</sub>	GND-0.3~V*+0.3	V
Power Dissipation	P <sub>D</sub>	(DIP8) 500	mW
		(DMP8) 300	mW
Operating Temperature Range	T <sub>opr</sub>	-20~+75	°C
Storage Temperature Range	T <sub>stg</sub>	-40~+125	°C

## ■ ELECTRICAL CHARACTERISTICS

(V\*=5V, Ta=25°C)

PARAMETER	SYMBOL	TEST CONDITION	MIN.	TYP.	MAX.	UNIT
Recommended Oper. Voltage Range	V*		4.7	5.0	5.3	V
Operating Current	I <sub>CC</sub>	S1=1, S2=1, input Vi1: 3.58MHz 1.0V <sub>p-p</sub> . Count Current	5.6	8	10.4	mA
Input Voltage Swing Range	V <sub>fsc</sub>	S1=1, S2=1, input Vi1: 3.58 or 4.43MHz (sine wave), guaranteed Vi1 voltage range.	0.5	1.0	2.0	V <sub>p-p</sub>
Input Sensitivity	V <sub>is</sub>	S1=1, S2=1, input Vi1: 3.58 or 4.43MHz (sine wave), actually tested minimum Vi1 voltage.	—	0.2	—	V <sub>p-p</sub>
VCO Oscillation Swing	V <sub>O3</sub>	S1=1, S2=2, input Vi1: 3.58MHz, 1.0V <sub>p-p</sub> .	0.7	0.9	1.1	V <sub>p-p</sub>
fsc Leakage	L <sub>fsc</sub>	S1=1, S2=2, input Vi1: 3.58MHz, 1.0V <sub>p-p</sub> . V <sub>O3</sub> (fsc level/3fsc level)	—	-50	—	dB
3fsc Output Duty	D <sub>3fsc</sub>	S1=1, S2=2, input Vi1: 3.58MHz, 1.0V <sub>p-p</sub> , V <sub>O3</sub> output signal duty.	45	50	55	%

## ■ TEST CIRCUIT

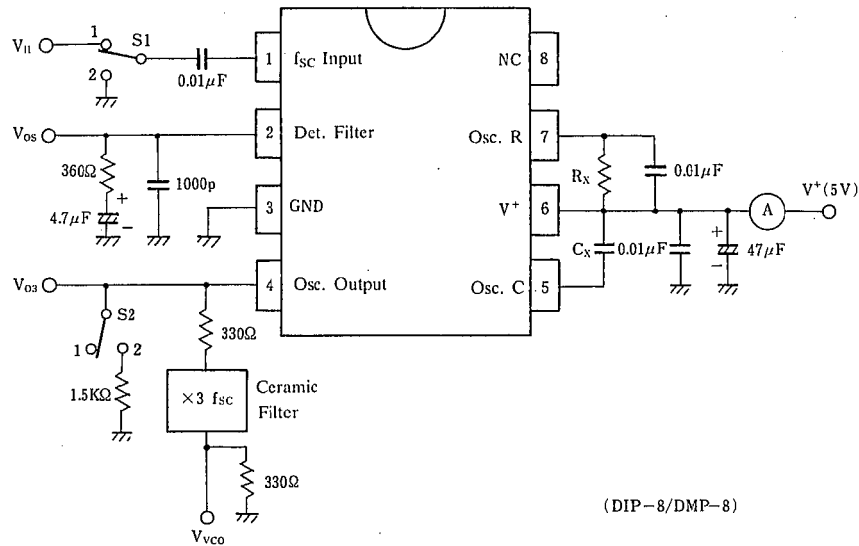

(note 1): Rx, Cx accuracy: less than  $\pm 1\%$

(note 2): Cx is not considered pin 5 stray capacitance. VCO free-run frequency is affected by stray capacitance of PC board, socket and others.

(note 3): The NJM2238 is produced by high frequency wafer process and some of pin may be weak against surge voltage.

(note 4): Pin 2 filter must be connected to ground.

5

## ■ TYPICAL CHARACTERISTICS

### VCO Oscillator Frequency

( $V_{os} = 2V$ ,  $T_a = 25^\circ C$ )

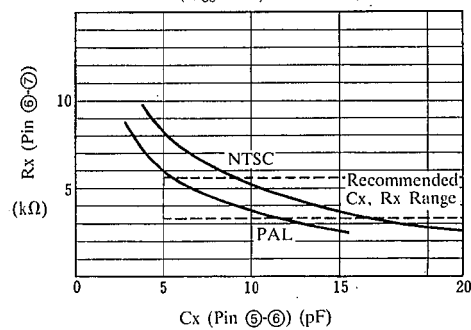

# NJM2238

---

## MEMO

**[CAUTION]**

The specifications on this databook are only given for information, without any guarantee as regards either mistakes or omissions. The application circuits in this databook are described only to show representative usages of the product and not intended for the guarantee or permission of any right including the industrial rights.