

VIDEO NOISE REDUCER

■ GENERAL DESCRIPTION

The NJM2210 is a video noise reducer IC of which operation is to reduce noise contained in video color and luminance signal and at the same time to correct outline of horizontal and vertical image signal.

The NJM2210 is suit for VCR camera especially.

■ PACKAGE OUTLINE

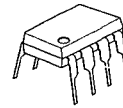

NJM2210D



NJM2210M

■ FEATURES

- Operating Voltage (+4.75V~+5.25V)
- It can compose Combtype Filter, with CCD IH delay line by that connect with
- It can be useful as Switching Noise Reduce Mode and Enhance Mode that are because of to Comb type Filter
- Package Outline DIP8, DMP8
- Bipolar Technology

■ RECOMMENDED OPERATING CONDITION

- Operating Voltage 4.75~5.25V

■ PIN CONFIGURATION

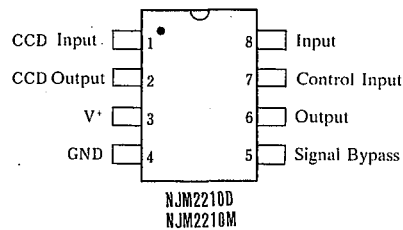

■ TEST CIRCUIT

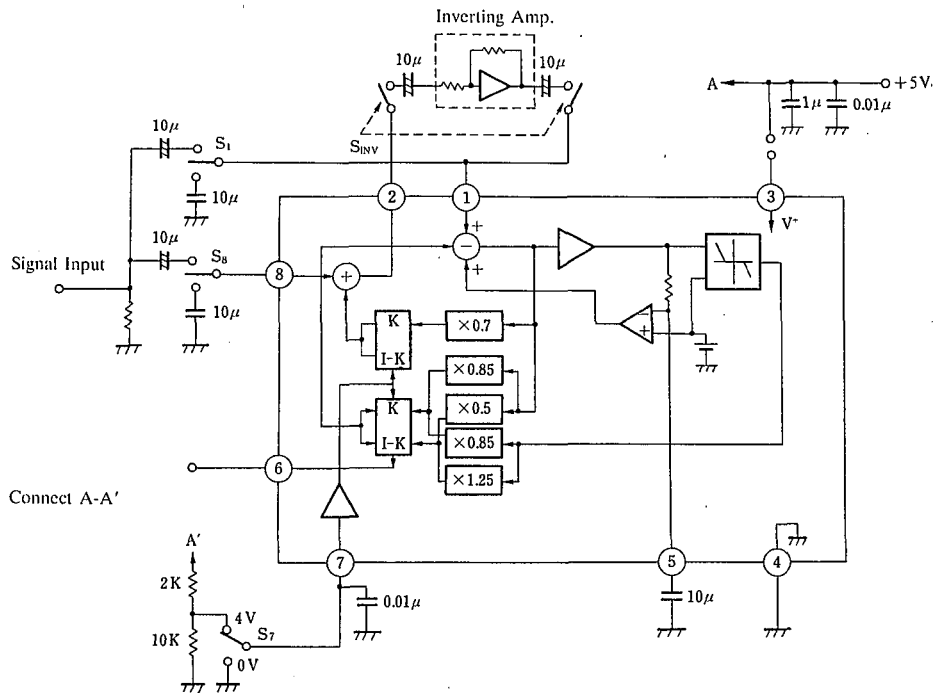

# NJM2210

## ■ ABSOLUTE MAXIMUM RATINGS

(Ta=25°C)

PARAMETER	SYMBOL	RATINGS	UNIT
Supply Voltage	V*	8	V
Power Dissipation	P <sub>D</sub>	(SIP8) 500 (DMP8) 300	mW mW
Operating Temperature Range	T <sub>opr</sub>	-20 ~ +75	°C
Storage Temperature Range	T <sub>stg</sub>	-40 ~ +125	°C

## ■ ELECTRICAL CHARACTERISTICS

(Ta=25°C, V\*=5V, F=100kHz)

PARAMETER	SYMBOL	TEST CONDITION	MIN.	TYP.	MAX.	UNIT
Operating Current	I <sub>CC</sub>		—	6.9	10	mA
Voltage Gain (Pin 8-Pin 2)	G <sub>V11</sub>	V <sub>7</sub> =4V V <sub>IN</sub> =100mV <sub>P-P</sub>	-1	0	+1	dB
	G <sub>V12</sub>	V <sub>7</sub> =0V V <sub>IN</sub> =100mV <sub>P-P</sub>	-11.5	-10	-8.5	
Voltage Gain (Pin 1-Pin 2)	G <sub>V21</sub>	V <sub>7</sub> =4V V <sub>IN</sub> =100mV <sub>P-P</sub>	—	-45	-38	dB
	G <sub>V22</sub>	V <sub>7</sub> =0V V <sub>IN</sub> =100mV <sub>P-P</sub>	-4.2	-3.2	-2.2	
Voltage Gain (Pin 8-Pin 6)	G <sub>V31</sub>	V <sub>7</sub> =4V V <sub>IN</sub> =100mV <sub>P-P</sub>	-2.0	-1.0	0	dB
	G <sub>V32</sub>	V <sub>7</sub> =0V V <sub>IN</sub> =100mV <sub>P-P</sub>	-2.0	-1.0	0	
	G <sub>V33</sub>	V <sub>7</sub> =4V Pin 2-1 (Inv. Amp) V <sub>IN</sub> =10mV <sub>P-P</sub>	—	-30	-18	
	G <sub>V34</sub>	V <sub>7</sub> =0V Pin 2-1 (Inv. Amp) V <sub>IN</sub> =10mV <sub>P-P</sub>	—	-30	-18	
	G <sub>V35</sub>	V <sub>7</sub> =4V Pin 2-1 (Inv. Amp) V <sub>IN</sub> =200mV <sub>P-P</sub>	3.5	5.0	6.5	
	G <sub>V36</sub>	V <sub>7</sub> =0V Pin 2-1 (Inv. Amp) V <sub>IN</sub> =200mV <sub>P-P</sub>	-5.0	-3.5	-2.0	
Voltage Gain (Pin 1-Pin 6)	G <sub>V41</sub>	V <sub>7</sub> =4V V <sub>IN</sub> =20mV <sub>P-P</sub>	-8.0	-7.0	-6.0	dB
	G <sub>V42</sub>	V <sub>7</sub> =0V V <sub>IN</sub> =20mV <sub>P-P</sub>	-3.4	-2.4	-1.4	
Bandwidth (Pin 8-Pin 2)	f <sub>B1</sub>	V <sub>7</sub> =4V V <sub>IN</sub> =100mV <sub>P-P</sub>	10	—	—	MHz
Bandwidth (Pin 1-Pin 2)	f <sub>B2</sub>	V <sub>7</sub> =0V V <sub>IN</sub> =100mV <sub>P-P</sub>	10	—	—	MHz
Bandwidth (Pin 8-Pin 6)	f <sub>B31</sub>	V <sub>7</sub> =4V V <sub>IN</sub> =100mV <sub>P-P</sub>	8	—	—	MHz
	f <sub>B32</sub>	V <sub>7</sub> =0V V <sub>IN</sub> =100mV <sub>P-P</sub>	8	—	—	

Note: Unless specified, all items are tested by test circuit.

■ TERMINAL FUNCTION

<p>1 CCD Input</p>		<p>5 Signal Bypass</p>	
<p>2 CCD Output</p>		<p>6 Output</p>	
<p>3 V+</p>		<p>7 Control Input</p>	
<p>4 GND</p>		<p>8 Input</p>	



# NJM2210

## APPLICATION NOTE

The NJM2210 is an integrated circuit of composing variable comb type filter which reduces noise mixed at chroma or luminance signal of VCR camera or others. Time delay element of comb type filter is fit to CCD delay element, not to glass delay line. The circuit is the most excellent FB with NULL system. Fig.1 is its basic block diagram and Fig.2 is actual block diagram of NJM2210.

Fig.3 is one of application examples.

This video noise reducer is composed of NJM2210, three capacitances for combination, one capacitance for signal bypass and CCD delay element. The NJM2210 is applicable to both of chroma and luminous signal with each fitted CCD delay element. The control terminal for switching reduce and enhance operates as enhance (increasing of high frequency part) with high level input and reduce (decreasing of high frequency part) with low level input. Its threshold level is about 2.25V at 5V supply voltage. Fig.4 is basic operating characteristics.

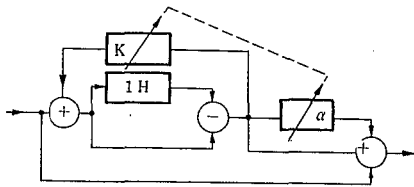

Fig.1 Basic Block Diagram

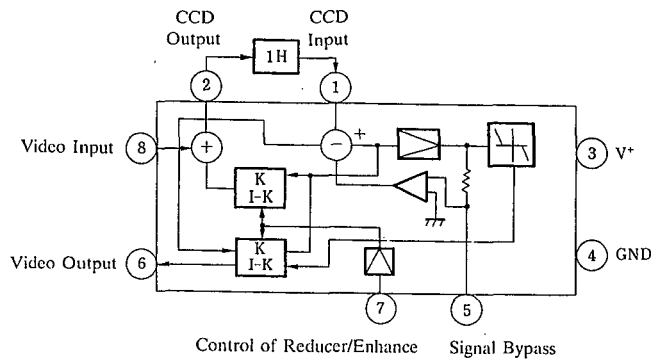

Fig.2 Block Diagram

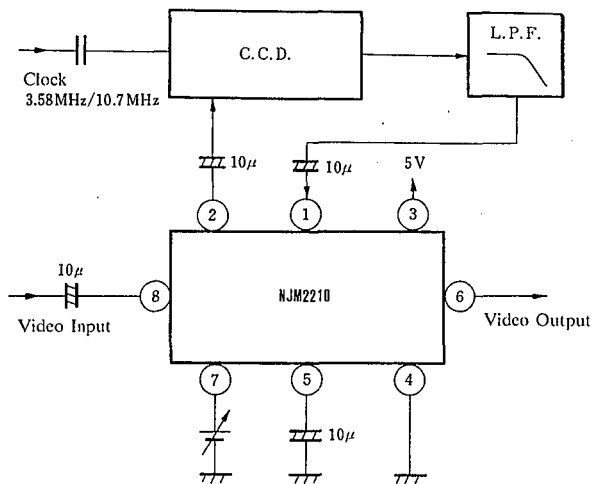

Fig.3 Application

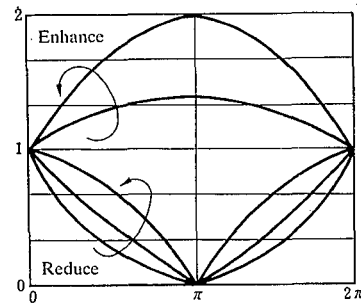

Fig.4 Basic Operating Characteristic

5

The comb type filter has special frequency characteristics like Fig.5 and is widely used to separate luminance and color signal in VCR circuit. The NJM2210 is automatical video signal noise reducer and signal enhancer. Fig.6 shows video signal wave form and its frequency component.

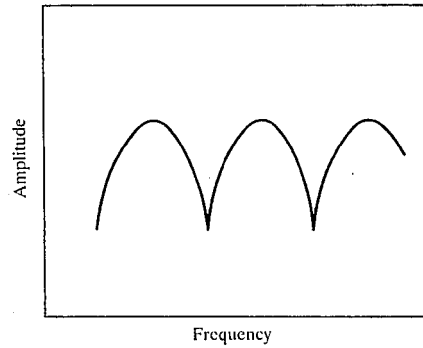

Fig.5 Comb Type Filter Frequency Characteristic

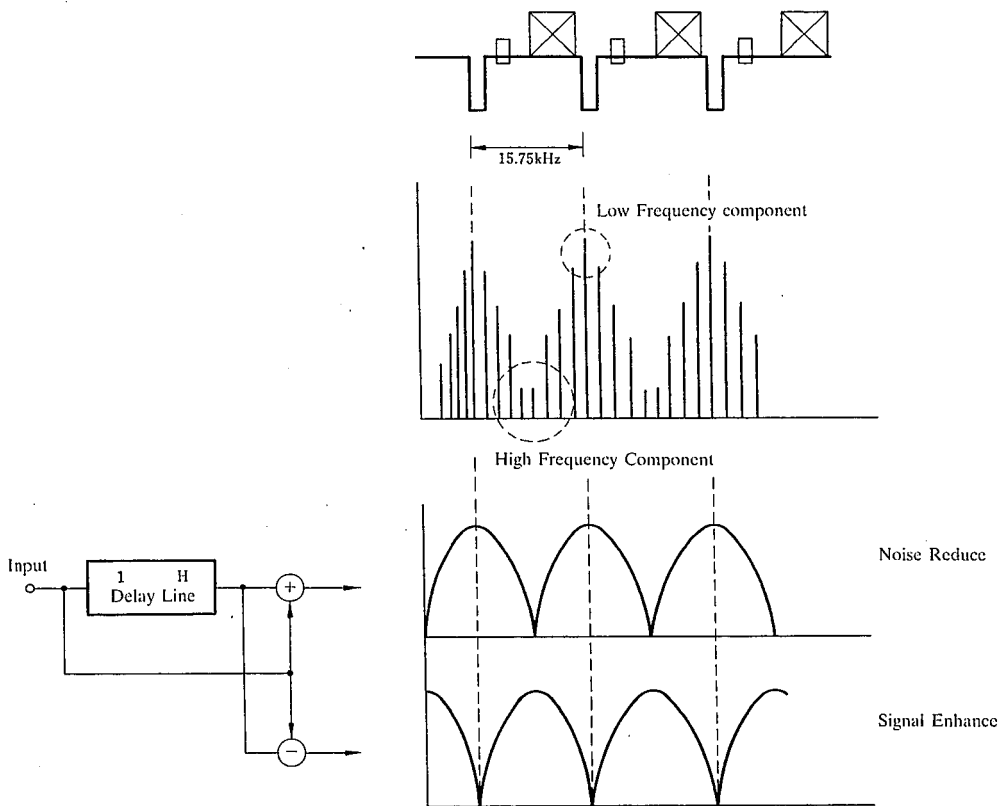

Fig.6 Video Signal Waveform & Frequency Component

5

# NJM2210

The NJM2210 operates automatically as noise reducer with low supply voltage to Pin 7 and signal enhancer with high voltage to Pin 7.

Fig.7 shows output characteristics when applied high or low voltage to Pin 7. This system is adding and subtracting form of signals and so the output characteristic distortion comb type filter comes from phase difference of each system. The NJM2210 phase difference is 2 degree at 4MHz. High dynamic range of video signal is realized by high supply voltage.

Fig.8 shows vertical and horizontal enhance on display. Vertical enhance is signal treatment within 1H of horizontal synchronous time. Horizontal enhance is signal treatment between each horizontal synchronous signal and Fig.9 shows this.

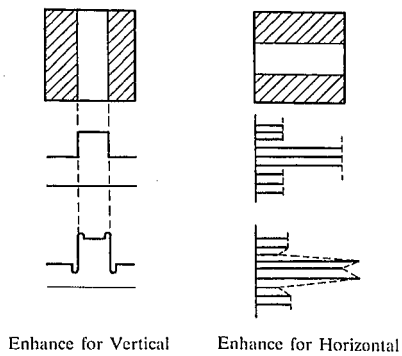

Fig.8

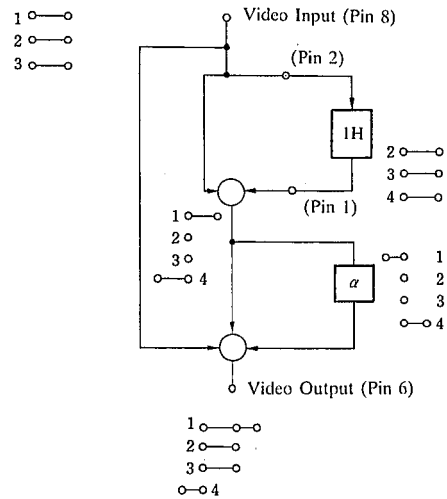
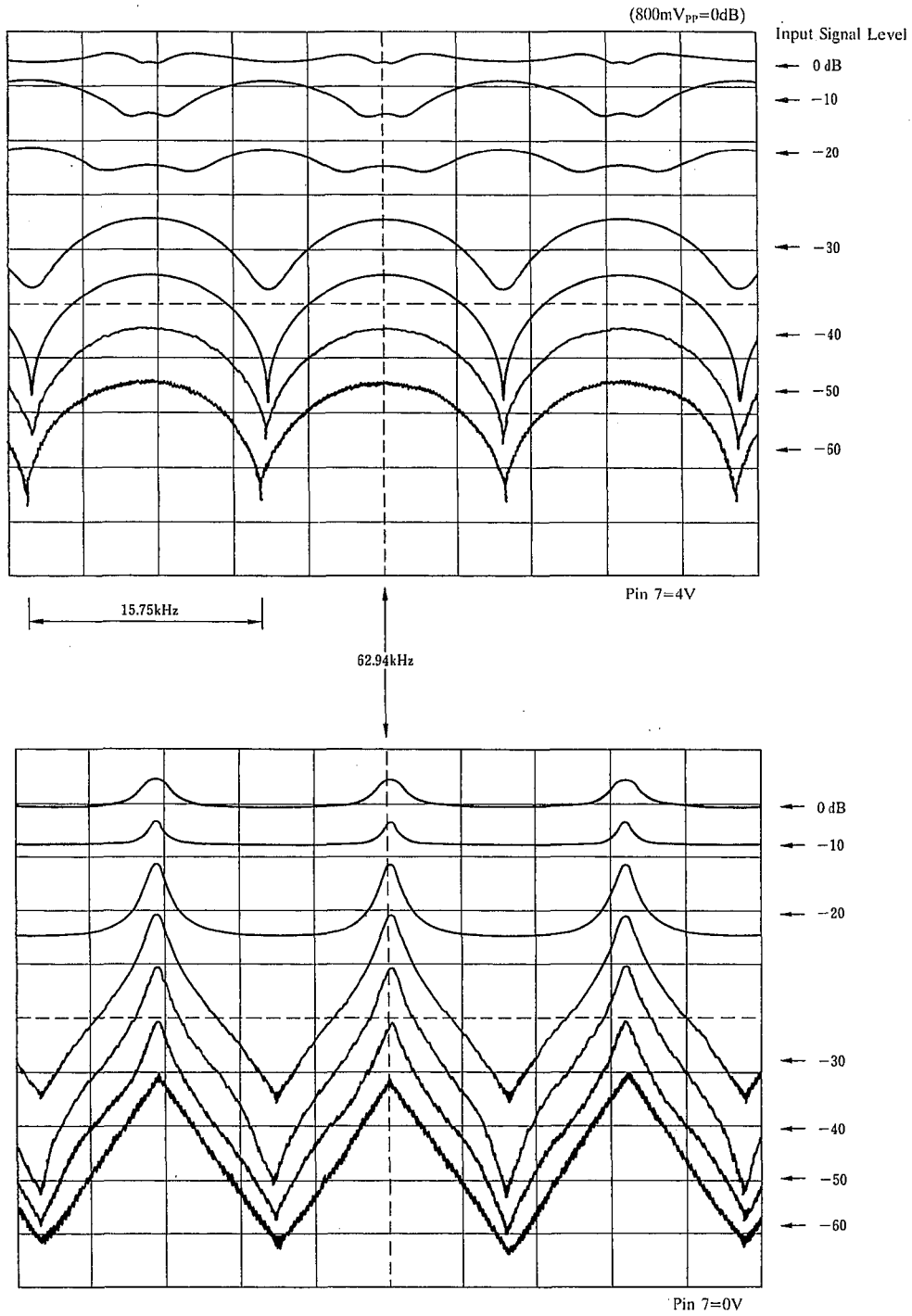

Fig.9 Block Explanation

5

Fig. 7 Comb Type Filter Characteristics vs. Input Signal Level (800mV<sub>pp</sub>=0dB)



5

# NJM2210

---

## MEMO

**[CAUTION]**

The specifications on this databook are only given for information, without any guarantee as regards either mistakes or omissions. The application circuits in this databook are described only to show representative usages of the product and not intended for the guarantee or permission of any right including the industrial rights.