

FSA1259A

Low-Voltage, 1Ω Dual SPST Analog Switch with Power-Off Isolation

Features

- Power-Off Isolation ($V_{CC}=0V$)
- 1Ω On Resistance (R_{ON}) for 4.5V V_{CC}
- 0.25Ω Maximum R_{ON} Flatness for 4.5V V_{CC}
- Space-Saving, US8 Surface Mount Package
- Broad V_{CC} Operating Range: 1.65V to 5.50V
- Fast Turn-On and Turn-Off Times
- Break-Before-Make Enable Circuitry

Description

The FSA1259A is a high-performance, dual, Single-Pole / Single-Throw (SPST) analog switch. The device features ultra-low R_{ON} of 1Ω at 4.5V V_{CC} and operates over the wide V_{CC} range of 1.65V to 5.50V.

The FS1259A allows for reduced input thresholds on the select pins.

The device is fabricated with sub-micron CMOS technology to achieve fast switching speeds and is designed for break-before-make operation.

Applications

- Cellular Phone
- Portable Media Player
- PDA

Ordering Information

Part Number	Top Mark	Operating Temperature Range	Package	Packing Method
FSA1259AK8X	59A	-40°C to +85°C	8-Lead US8, JEDEC MO-187, Variation CA, 3.0mm Wide	3000 Units Tape and Reel

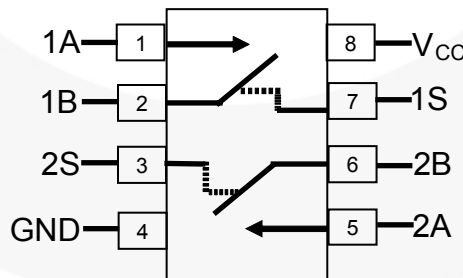

Figure 1. Analog Symbols

Pin Assignments

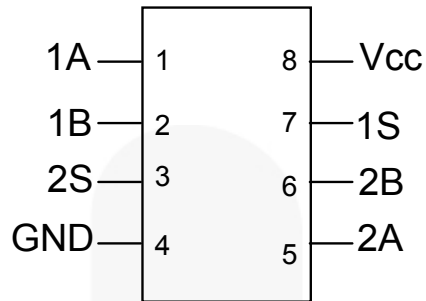

Figure 2. Pin Assignments (Top View)

Pin Definitions

Pin #	Name	Description
1	1A	Data Port
2	1B	Data Port
3	2S	Control Input
4	GND	Ground
5	2A	Data Port
6	2B	Data Port
7	1S	Control Input
8	V _{CC}	Supply Voltage

Truth Table

Control Input (S)	Function
LOW	Disconnected
HIGH	A Connected to B

Absolute Maximum Ratings

Stresses exceeding the absolute maximum ratings may damage the device. The device may not function or be operable above the recommended operating conditions and stressing the parts to these levels is not recommended. In addition, extended exposure to stresses above the recommended operating conditions may affect device reliability. The absolute maximum ratings are stress ratings only.

Symbol	Parameter	Min.	Max.	Unit
V _{CC}	Supply Voltage	-0.5	7.0	V
V _{SW}	Switch Voltage ⁽¹⁾	-0.5	V _{CC} +0.5	V
V _{IN}	Input Voltage ⁽¹⁾	-0.5	6.5	V
I _{IK}	Input Diode Current		-50	mA
I _{SW}	Switch Current (Continuous)		200	mA
I _{SWPEAK}	Peak Switch Current (Pulsed at 1ms Duration, <10% Duty Cycle)		400	mA
P _D	Power Dissipation at 85°C		3.0	μW
T _{STG}	Storage Temperature Range	-65	+150	°C
T _J	Maximum Junction Temperature		+150	°C
T _L	Lead Temperature (Soldering, 10 seconds)		+260	°C
ESD	Human Body Model (JEDEC: JESD22-A114)		8000	V
	Charged Device Model (JEDEC: JESD22-C101)		2000	V
	Machine Model (JEDEC: JESD22-A115)		350	V

Note:

- The input and output negative ratings may be exceeded if the input and output diode current ratings are observed.

Recommended Operating Conditions

The Recommended Operating Conditions table defines the conditions for actual device operation. Recommended operating conditions are specified to ensure optimal performance to the datasheet specifications. Fairchild does not recommend exceeding them or designing to Absolute Maximum Ratings.

Symbol	Parameter	Min.	Max.	Unit
V _{CC}	Supply Voltage	1.65	5.50	V
A _{SEL}	Control Input Voltage ⁽²⁾	0	V _{CC}	V
V _{SW}	Switch Input Voltage	0	V _{CC}	V
T _A	Operating Temperature	-40	+85	°C
θ _{JA}	Thermal Resistance, Still Air		215	°C/W

Note:

- Control Input must be held HIGH or LOW; it must not float.

Electrical Characteristics

All typical values are at 25°C unless otherwise specified.

Symbol	Parameter	V _{CC} (V)	Conditions	T _A =+25°C			T _A =-40 to +85°C		Unit
				Min.	Typ.	Max.	Min.	Max.	
V _{IH}	Input Voltage High	4.50 to 5.50					1.0		V
		3.00 to 3.60					1.0		
		2.30 to 2.70					0.95		
		1.65 to 1.95					0.95		
V _{IL}	Input Voltage Low	4.50 to 5.50						0.75	V
		3.00 to 3.60						0.65	
		2.30 to 2.70						0.55	
		1.65 to 1.95						0.5	
I _{IN}	Control Input Leakage	5.50	V _{IN} =0 or V _{CC}	-10		10	-50	50	nA
		3.60	V _{IN} =0 or V _{CC}	-2		2	-20	20	
		2.70	V _{IN} =0 or V _{CC}	-2		2	-20	20	
		1.95	V _{IN} =0 or V _{CC}	-2		2	-20	20	
I _{NO(OFF)}	Off-Leakage Current	5.50	A=1V, B=4.5V or B=4.5, A=1V	-10		10	-50	50	nA
		3.60	A=1V, B=4.5V or B=4.5, A=1V	-5		5	-50	50	
		2.70	A=0.5V, B=2.3V or B=2.3, A=0.5V	-5		5	-50	50	
		1.95	A=0.3V, B=1.65V or B=1.65, A=0.3V	-5		5	-50	50	
I _{NO(ON)}	On-Leakage Current of Port B	5.50	A=Floating; B=4.5V, 1V	-5		5	-50	50	nA
		3.60	A=Floating; B=3.0V, 1V	-2		2	-20	20	
		2.70	A=Floating; B=2.3V, 0.5V	-2		2	-20	20	
		1.95	A=Floating; B=1.65V, 0.3V	-2		2	-20	20	
I _{A(ON)}	On-Leakage Current of Port A	5.50	A=1V, 4.5V; B=Floating	-5		5	-50	50	nA
		3.60	A=1V, 3.0V; B=Floating	-2		2	-20	20	
		2.70	A=0.5V, 2.3; B=Floating	-2		2	-20	20	
		1.95	A=0.3V, 1.65V; B=Floating	-2		2	-20	20	
I _{OFF}	Power Off Leakage Current of Port A & Port B	0	A=0 to 5.5V; B=0 to 5.5V	-1		1	-10	10	μA

Electrical Characteristics (Continued)

All typical values are at 25°C unless otherwise specified.

Symbol	Parameter	V _{CC} (V)	Conditions	T _A =+25°C			T _A =-40 to +85°C		Unit
				Min.	Typ.	Max.	Min.	Max.	
R _{PEAK}	Peak On Resistance	4.50	I _{OUT} =-100mA, 1B or 2B=0 to V _{CC}		0.8	1.0		1.2	Ω
		3.00	I _{OUT} =-100mA, 1B or 2B=0 to V _{CC}		1.0	1.5		1.8	
		2.30	I _{OUT} =-8mA, 1B or 2B=0 to V _{CC}		1.5	2.0		2.5	
		1.65	I _{OUT} =-2mA, 1B or 2B=0 to V _{CC}	T _A =25, 85°C	5.0	12.0		15.0	
T _A =-40°C	20.0								
R _{ON}	Switch On Resistance ⁽³⁾	4.50	I _{OUT} =-100mA, 1B or 2B=2.5V		0.70	0.85		1.00	Ω
		3.00	I _{OUT} =-100mA, 1B or 2B=2.0V		0.9	1.3		1.6	
		2.30	I _{OUT} =-8mA, 1B or 2B=1.8V		1.4	2.0		2.4	
		1.65	I _{OUT} =-2mA, 1B or 2B=1.5V		2.0	2.5		3.5	
ΔR _{ON}	On Resistance Matching Between Channels ⁽⁴⁾	4.50	I _{OUT} =-100mA, 1B or 2B=2.5V		0.05	0.10		0.10	Ω
		3.00	I _{OUT} =-100mA, 1B or 2B=2.0V		0.10	0.15		0.15	
		2.30	I _{OUT} =-8mA, 1B or 2B=1.8V		0.15	0.20		0.20	
		1.65	I _{OUT} =-2mA, 1B or 2B=1.5V		0.15	0.40		0.40	
R _{FLAT(ON)}	On Resistance Flatness ⁽⁵⁾	4.50	I _{OUT} =-100mA, 1B or 2B=1.0V, 1.5V, 2.5V		0.10	0.25		0.25	Ω
		3.00	I _{OUT} =-100mA, 1B or 2B=0.8V, 2.0V		0.1	0.3		0.3	
		2.30	I _{OUT} =-8mA, 1B or 2B=0.8V, 1.8V		0.2	1.0		1.0	
		1.65	I _{OUT} =-2mA, 1B or 2B=0.6V, 1.5V		1.5				
I _{CC}	Quiescent Supply Current	5.50	V _{IN} =0 or V _{CC} , I _{OUT} =0		5	50		500	nA
		3.60	V _{IN} =0 or V _{CC} , I _{OUT} =0		1	25		300	
		2.70	V _{IN} =0 or V _{CC} , I _{OUT} =0		1	20		250	
		1.95	V _{IN} =0 or V _{CC} , I _{OUT} =0		1	15		150	
I _{CC(T)}	Increase in I _{CC} per Control Input	4.5 to 5.5	Asel=1.8V		25			40	μA

Notes:

3. On resistance is determined by the voltage drop between the A and B pins at the indicated current through the switch.
4. ΔR_{ON}=R_{ON} maximum – R_{ON} minimum; measured at identical V_{CC}, temperature, and voltage.
5. Flatness is defined as the difference between the maximum and minimum value of on resistance over the specified range of conditions.

AC Electrical Characteristics

All typical values are at $V_{CC}=1.8V, 2.5V, 3.0V, 5.0V$ at $25^{\circ}C$ unless otherwise specified.

Symbol	Parameter	V_{CC} (V)	Conditions	$T_A=+25^{\circ}C$			$T_A=-40to+85^{\circ}C$		Unit	Figure
				Min.	Typ.	Max.	Min.	Max.		
t_{ON}	Turn-On Time	4.50 to 5.50	1B or 2B= V_{CC} , $R_L=50\Omega$, $C_L=35pF$	1.0	4.0	7.5	1.0	9.0	ns	Figure 11
		3.00 to 3.60		1.5	6.0	9.5	1.0	10.0		
		2.30 to 2.70		2.0	8.0	10.0	1.0	12.0		
		1.65 to 1.95		3.0	14.0	18.0	1.0	20.0		
t_{OFF}	Turn-Off Time	4.50 to 5.50	1B or 2B= V_{CC} , $R_L=50\Omega$, $C_L=35pF$	4.5	13.0	17.0	3.5	20.0	ns	Figure 11
		3.00 to 3.60		4.5	13.5	17.0	3.0	20.0		
		2.30 to 2.70		4.5	16.0	20.0	3.0	23.0		
		1.65 to 1.95		5.0	24.0	33.0	4.0	36.0		
Q	Charge Injection	4.50 to 5.50	$C_L=1.0nF$, $V_{GEN}=0V$, $R_{GEN}=0\Omega$		15				pC	Figure 13
		3.00 to 3.60			11					
		2.30 to 2.70			8					
		1.65 to 1.95			6					
OIRR	Off-Isolation	1.8 to 5.0	$f=1MHz$, $R_L=50\Omega$		-60				dB	Figure 12
Xtalk	Crosstalk	1.8 to 5.0	$f=1MHz$, $R_L=50\Omega$		-73				dB	Figure 12
BW	-3db Bandwidth	4.50 to 5.50	$R_L=50\Omega$		240				MHz	Figure 15
		3.00 to 3.60			240					
		2.30 to 2.70			240					
		1.65 to 1.95			240					
THD	Total Harmonic Distortion	1.8	$R_L=600\Omega$, $V_{IN}=0.5V_{PP}$, $f=20Hz$ to $20kHz$.003				%	Figure 16
		5.0			.001					Figure 16

Capacitance

Symbol	Parameter	V_{CC} (V)	Conditions	$T_A=+25^{\circ}C$			Unit
				Min.	Typ.	Max.	
C_{IN}	Control Pin Input Capacitance	0	$f=1MHz$ Figure 14		3		pF
C_{OFF}	B Port Off Capacitance	1.65 to 5.50	$f=1MHz$ Figure 14		21		pF
C_{ON}	A Port On Capacitance	1.65 to 5.50	$f=1MHz$ Figure 14		47		pF

Typical Performance Characteristics

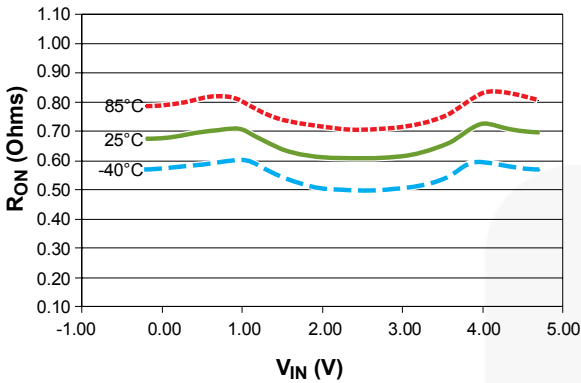

Figure 3. On Resistance ($V_{CC}=4.5V$)

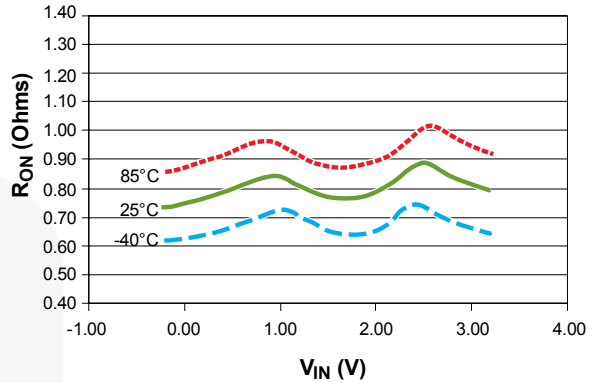

Figure 4. On Resistance ($V_{CC}=3.0V$)

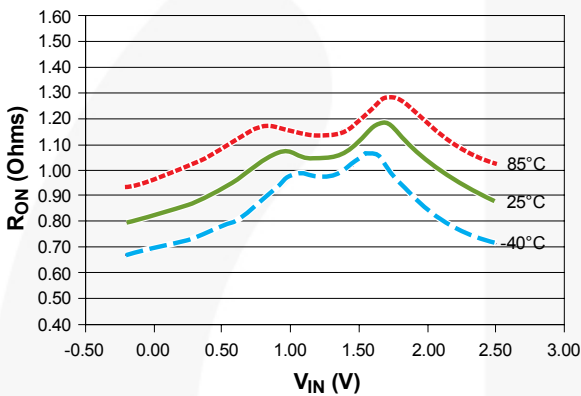

Figure 5. On Resistance ($V_{CC}=2.3V$)

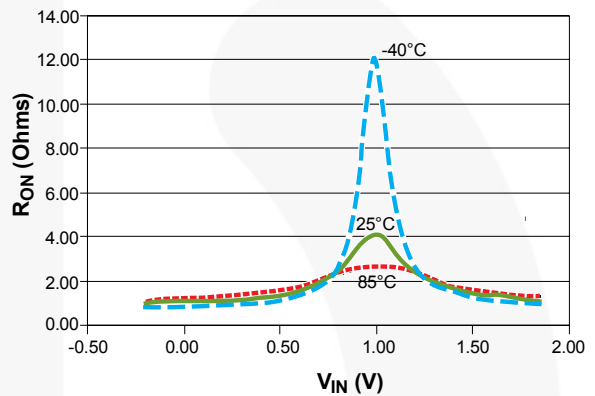

Figure 6. On Resistance ($V_{CC}=1.65V$)

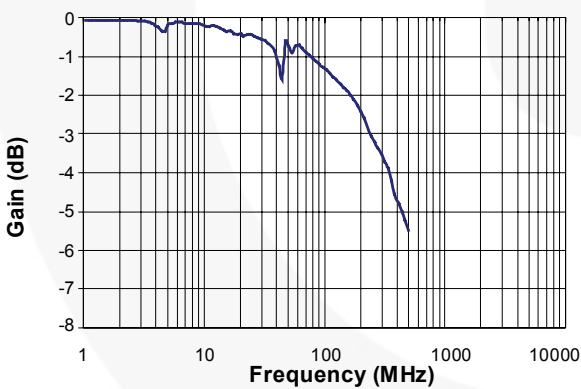

Figure 7. Frequency Response ($V_{CC}=5.5V, C_L=0pF$)

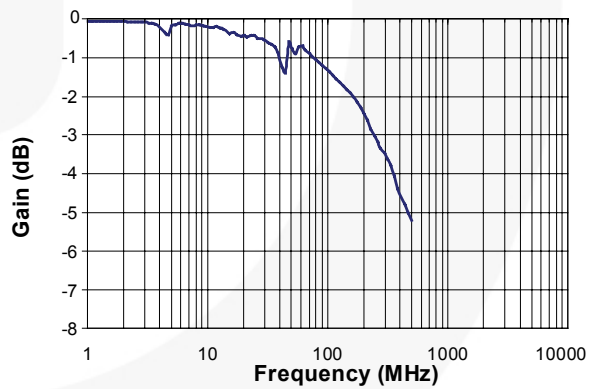

Figure 8. Frequency Response ($V_{CC}=3.3V, C_L=0pF$)

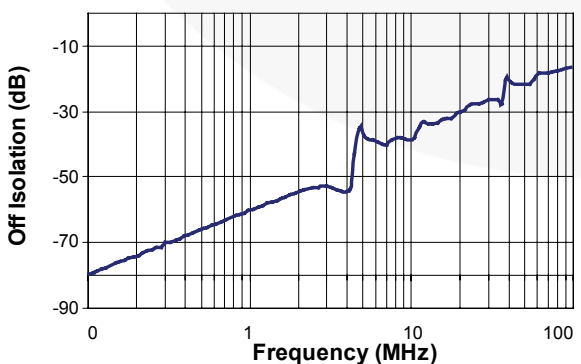

Figure 9. Frequency Response ($V_{CC}=5.0V, C_L=0pF$)

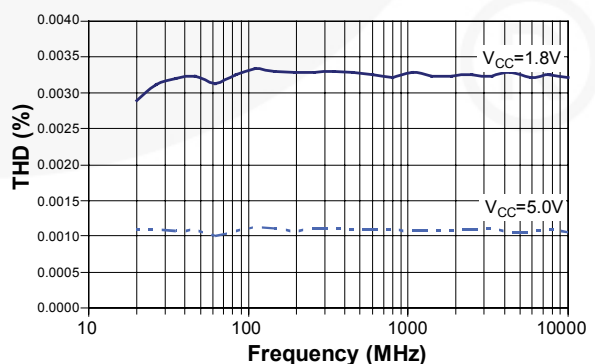

Figure 10. Total Harmonic Distortion

Test Diagrams

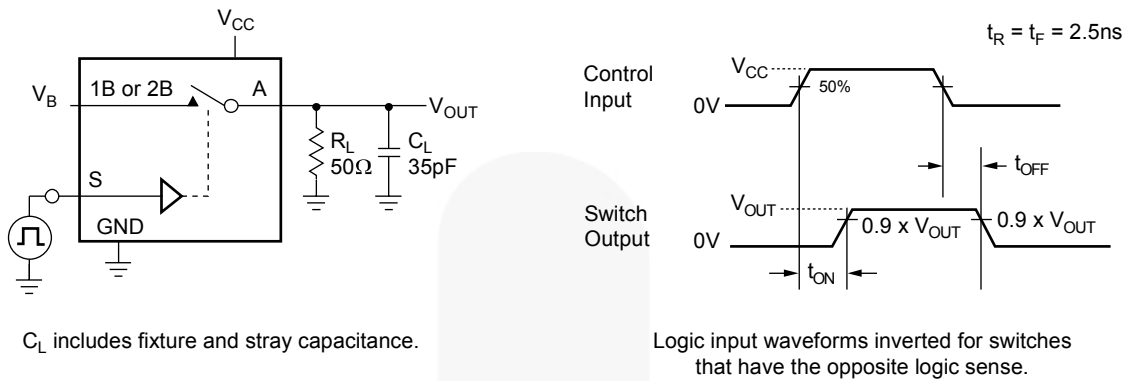

Figure 11. Turn On / Off Timing

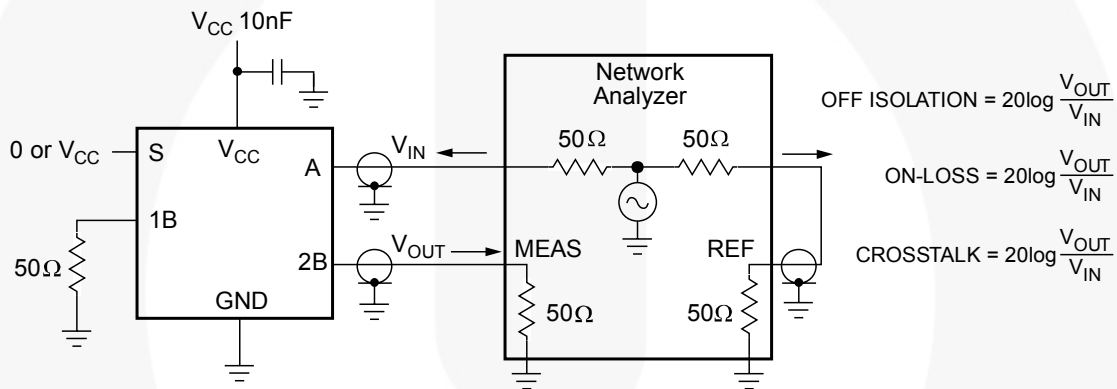

Figure 12. Off Isolation and Crosstalk

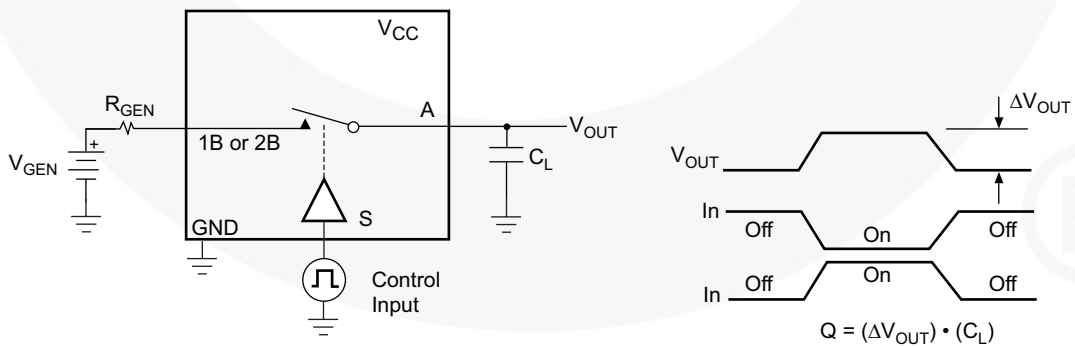

Figure 13. Charge Injection

Test Diagrams (Continued)

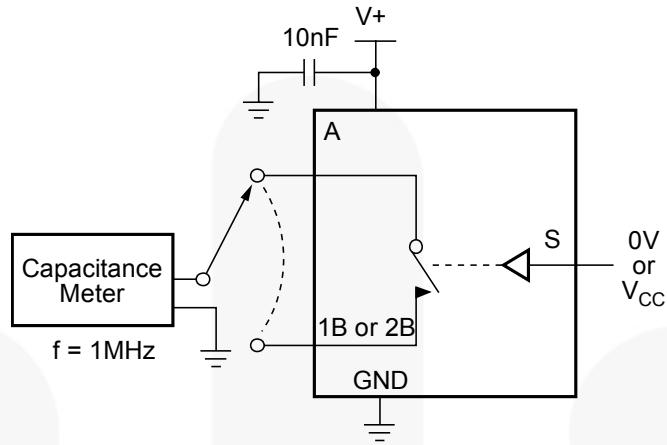

Figure 14. On / Off Capacitance Measurement Setup

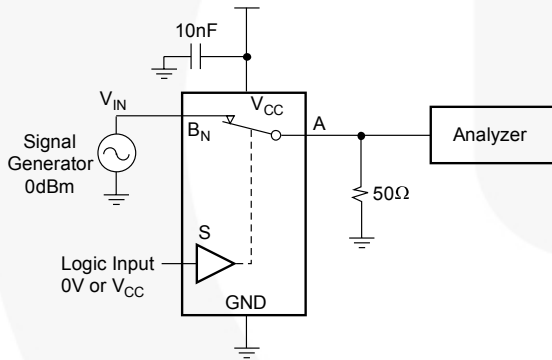

Figure 15. Bandwidth

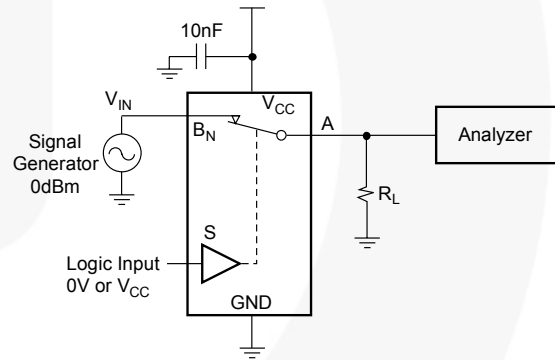
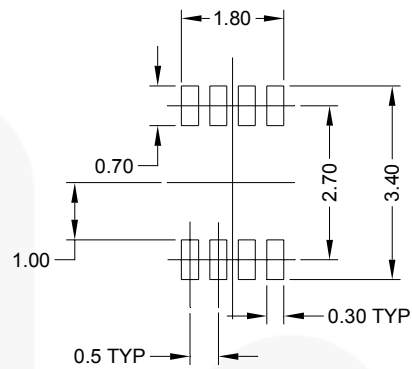
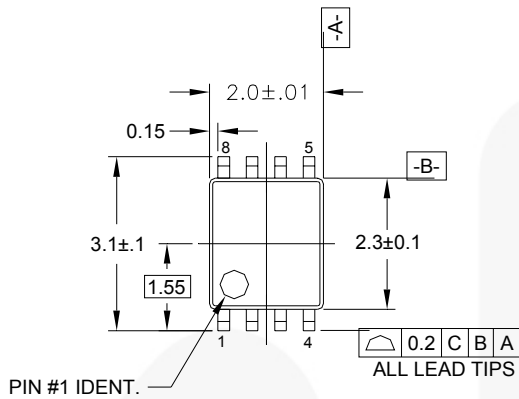
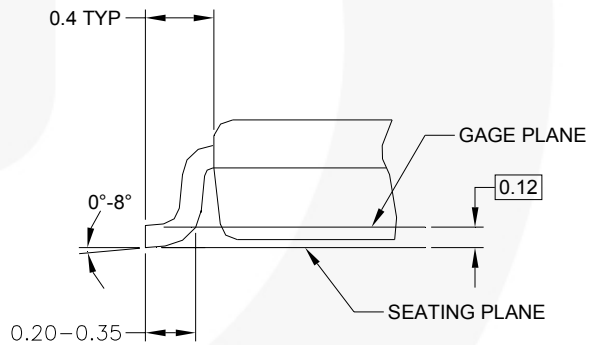
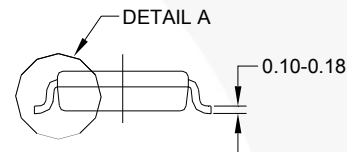
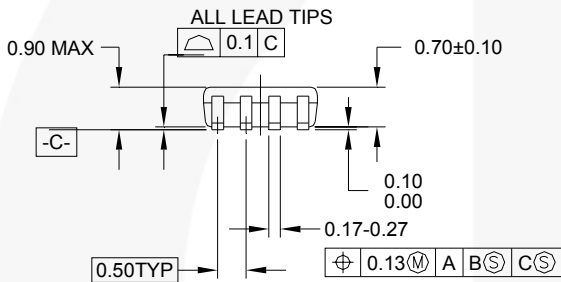

Figure 16. Harmonic Distortion

Physical Dimensions



LAND PATTERN RECOMMENDATION



DETAIL A

NOTES:

- A. CONFORMS TO JEDEC REGISTRATION MO-187
- B. DIMENSIONS ARE IN MILLIMETERS.
- C. DIMENSIONS ARE EXCLUSIVE OF BURRS, MOLD FLASH, AND TIE BAR EXTRUSIONS.
- D. DIMENSIONS AND TOLERANCES PER ANSI Y14.5M, 1982.

MAB08AREVC

Figure 17. 8-Lead US8, JEDEC MO-187, Variation CA, 3.0mm Wide Package

Package drawings are provided as a service to customers considering Fairchild components. Drawings may change in any manner without notice. Please note the revision and/or date on the drawing and contact a Fairchild Semiconductor representative to verify or obtain the most recent revision. Package specifications do not expand the terms of Fairchild's worldwide terms and conditions, specifically the warranty therein, which covers Fairchild products.

Always visit Fairchild Semiconductor's online packaging area for the most recent package drawings:
<http://www.fairchildsemi.com/packaging/>.



TRADEMARKS

The following includes registered and unregistered trademarks and service marks, owned by Fairchild Semiconductor and/or its global subsidiaries, and is not intended to be an exhaustive list of all such trademarks.

- | | | | |
|---|---|---|--|
| AccuPower™ | F-PFS™ | Power-SPM™ |  SYSTEM GENERAL
The Power Franchise®
 power franchise
TinyBoost™
TinyBuck™
TinyCalc™
TinyLogic®
TINYOPTO™
TinyPower™
TinyPWM™
TinyWire™
TriFault Detect™
TRUECURRENT™*
μSerDes™
 SerDes
UHC®
Ultra FRFET™
UniFET™
VCX™
VisualMax™
XST™ |
| Auto-SPM™ | FRFET® | PowerTrench® | |
| Build it Now™ | Global Power Resource SM | PowerXS™ | |
| CorePLUS™ | Green FPS™ | Programmable Active Droop™ | |
| CorePOWER™ | Green FPS™ e-Series™ | QFET® | |
| CROSSVOLT™ | Gmax™ | QS™ | |
| CTL™ | GTO™ | Quiet Series™ | |
| Current Transfer Logic™ | IntelliMAX™ | RapidConfigure™ | |
| DEUXPEED® | ISOPLANAR™ |  ™ | |
| Dual Cool™ | MegaBuck™ | Saving our world, 1mW/W/kW at a time™ | |
| EcoSPARK® | MICROCOUPLER™ | SignalWise™ | |
| EfficientMax™ | MicroFET™ | SmartMax™ | |
| ESBC™ | MicroPak™ | SMART START™ | |
|  ™ | MicroPak2™ | SPM® | |
| Fairchild® | MillerDrive™ | STEALTH™ | |
| Fairchild Semiconductor® | MotionMax™ | SuperFET™ | |
| FACT Quiet Series™ | Motion-SPM™ | SuperSOT™.3 | |
| FACT® | OptoHIT™ | SuperSOT™.8 | |
| FAST® | OPTOLOGIC® | SuperSOT™.8 | |
| FastvCore™ | OPTOPLANAR® | SupreMOS™ | |
| FETBench™ |  ™ | SyncFET™ | |
| FlashWriter SM | PDP SPM™ | Sync-Lock™ | |
| FPS™ | | | |

* Trademarks of System General Corporation, used under license by Fairchild Semiconductor.

DISCLAIMER

FAIRCHILD SEMICONDUCTOR RESERVES THE RIGHT TO MAKE CHANGES WITHOUT FURTHER NOTICE TO ANY PRODUCTS HEREIN TO IMPROVE RELIABILITY, FUNCTION, OR DESIGN. FAIRCHILD DOES NOT ASSUME ANY LIABILITY ARISING OUT OF THE APPLICATION OR USE OF ANY PRODUCT OR CIRCUIT DESCRIBED HEREIN; NEITHER DOES IT CONVEY ANY LICENSE UNDER ITS PATENT RIGHTS, NOR THE RIGHTS OF OTHERS. THESE SPECIFICATIONS DO NOT EXPAND THE TERMS OF FAIRCHILD'S WORLDWIDE TERMS AND CONDITIONS, SPECIFICALLY THE WARRANTY THEREIN, WHICH COVERS THESE PRODUCTS.

LIFE SUPPORT POLICY

FAIRCHILD'S PRODUCTS ARE NOT AUTHORIZED FOR USE AS CRITICAL COMPONENTS IN LIFE SUPPORT DEVICES OR SYSTEMS WITHOUT THE EXPRESS WRITTEN APPROVAL OF FAIRCHILD SEMICONDUCTOR CORPORATION.

As used herein:

- Life support devices or systems are devices or systems which, (a) are intended for surgical implant into the body or (b) support or sustain life, and (c) whose failure to perform when properly used in accordance with instructions for use provided in the labeling, can be reasonably expected to result in a significant injury of the user.
- A critical component in any component of a life support, device, or system whose failure to perform can be reasonably expected to cause the failure of the life support device or system, or to affect its safety or effectiveness.

ANTI-COUNTERFEITING POLICY

Fairchild Semiconductor Corporation's Anti-Counterfeiting Policy. Fairchild's Anti-Counterfeiting Policy is also stated on our external website, www.fairchildsemi.com, under Sales Support.

Counterfeiting of semiconductor parts is a growing problem in the industry. All manufacturers of semiconductor products are experiencing counterfeiting of their parts. Customers who inadvertently purchase counterfeit parts experience many problems such as loss of brand reputation, substandard performance, failed applications, and increased cost of production and manufacturing delays. Fairchild is taking strong measures to protect ourselves and our customers from the proliferation of counterfeit parts. Fairchild strongly encourages customers to purchase Fairchild parts either directly from Fairchild or from Authorized Fairchild Distributors who are listed by country on our web page cited above. Products customers buy either from Fairchild directly or from Authorized Fairchild Distributors are genuine parts, have full traceability, meet Fairchild's quality standards for handling and storage and provide access to Fairchild's full range of up-to-date technical and product information. Fairchild and our Authorized Distributors will stand behind all warranties and will appropriately address any warranty issues that may arise. Fairchild will not provide any warranty coverage or other assistance for parts bought from Unauthorized Sources. Fairchild is committed to combat this global problem and encourage our customers to do their part in stopping this practice by buying direct or from authorized distributors.

PRODUCT STATUS DEFINITIONS

Definition of Terms

Datasheet Identification	Product Status	Definition
Advance Information	Formative / In Design	Datasheet contains the design specifications for product development. Specifications may change in any manner without notice.
Preliminary	First Production	Datasheet contains preliminary data; supplementary data will be published at a later date. Fairchild Semiconductor reserves the right to make changes at any time without notice to improve design.
No Identification Needed	Full Production	Datasheet contains final specifications. Fairchild Semiconductor reserves the right to make changes at any time without notice to improve the design.
Obsolete	Not In Production	Datasheet contains specifications on a product that is discontinued by Fairchild Semiconductor. The datasheet is for reference information only.

Rev. 148