

DS9622 Dual Line Receiver

General Description

The DS9622 is a dual line receiver designed to discriminate a worst case logic swing of 2V from a $\pm 10V$ common mode noise signal or ground shift. A 1.5V threshold is built into the differential amplifier to offer a TTL compatible threshold voltage and maximum noise immunity. The offset is obtained by use of current sources and matched resistors.

The DS9622 allows the choice of output states with the input open, without affecting circuit performance by use of S3. A 130Ω terminating resistor is provided at the input of each line receiver. An enable is also provided for each line receiver. The output is TTL compatible. The output high level can be increased to 12V by tying it to a positive supply through a resistor. The output circuits allow wired-OR operation.

Features

- TTL compatible threshold voltage
- Input terminating resistors
- Choice of output state with inputs open
- TTL compatible output
- High common mode
- Wired-OR capability
- Enable inputs
- Logic compatible supply voltages

Connection Diagram

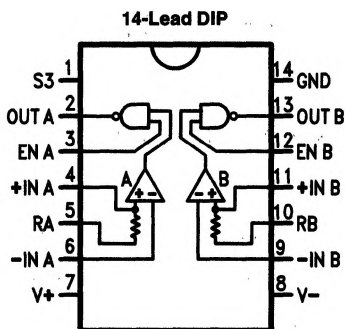

TL/F/9760-2

Top View

For Complete Military 883 Specifications, see RETS Datasheet.

Order Number DS9622ME/883,

DS9622MJ/883 or DS9622MW/883

See NS Package Number E20A, J14A or W14B

Absolute Maximum Ratings (Note 1)

If Military/Aerospace specified devices are required, please contact the National Semiconductor Sales Office/Distributors for availability and specifications.

Storage Temperature Range	-65°C to +175°C
Operating Temperature Range	-55°C to +125°C
Lead Temperature (Soldering, 60 sec.)	300°C
Internal Power Dissipation (Note 5)	400 mW
V ⁺ to GND	-0.5V to +7.0V
Input Voltage	±15V

Voltage Applied to Outputs

for Output High State

-0.5V to +13.2V

V⁻ to GND

-0.5V to -12V

Enable to GND

-0.5V to +15V

Operating Conditions

	Min	Max	Units
Supply Voltage, V _{CC}	4.5	5.5	V
Temperature, T _A	-55	+125	°C

Electrical Characteristics (Notes 2, 3)

Symbol	Parameter	Conditions	Min	Max	Units	
V _{OL}	Output Voltage LOW	V ⁺ = S3 = 4.5V, V ⁻ = -11V, V _{DIFF} = 2.0V, I _{OL} = 12.4 mA, EN = Open		0.4	V	
V _{OH}	Output Voltage HIGH	V ⁺ = 4.5V, V ⁻ = -9.0V, S3 = 0V, V _{DIFF} = 1.0V, I _{OH} = -0.2 mA, EN = Open	2.8		V	
I _{CEX}	Output Leakage Current	V ⁺ = 4.5V, V ⁻ = -11V, S3 = 0V, V _{DIFF} = 1.0V, V _O = 12V, EN = Open		200	μA	
I _{OS}	Output Short Circuit Current (Note 4)	V ⁺ = 5.0V, V ⁻ = -10V, V _{DIFF} = 1.0V, V _O = S3 = 0V, EN = Open	-3.1	-1.4	mA	
I _R (EN)	Enable Input Leakage Current	V ⁺ = S3 = 4.5V, V ⁻ = -11V, I _N = Open, EN = 4.0V		5.0	μA	
I _F (EN)	Enable Input Forward Current	V ⁺ = 5.5V, V ⁻ = -9.0V V _I = Open, EN = S3 = 0V	-1.5		mA	
I _F (+IN)	+ Input Forward Current	V ⁺ = 5.0V, V ⁻ = -10V, V _{I+} = 0V, V _{I-} = GND, EN = S3 = Open	-2.3		mA	
I _F (-IN)	- Input Forward Current	V ⁺ = S3 = 5.0V, V ⁻ = -10V, V _{I+} = GND, V _{I-} = 0V, EN = Open	-2.6		mA	
V _{IL} (EN)	Input Voltage LOW	4.5V ≤ V ⁺ ≤ 5.5V, -11V ≤ V ⁻ ≤ -9.0V, EN = Open	+25°C	1.0	V	
			+125°C	0.7	V	
			-55°C	1.3	V	
V _{TH}	Differential Input Threshold Voltage	4.5V ≤ V ⁺ ≤ 5.5V, -11V ≤ V ⁻ ≤ -9.0V, EN = Open	1.0	2.0	V	
V _{CM}	Common Mode Voltage	V ⁺ = 5.0V, V ⁻ = -10V, 1.0V ≤ V _{DIFF} ≤ 2.0V	25°C	-10	+10	V
R _T	Terminating Resistance		25°C	91	215	Ω
I ⁺	Positive Supply Current	V ⁺ = S3 = V _{I+} = 5.5V, V ⁻ = 11V, V _{I-} = 0V	25°C		22.9	mA
I ⁻	Negative Supply Current			-11.1		mA

SWITCHING CHARACTERISTICS T_A = 25°C

t _{PLH}	Propagation Delay to High Level	V ⁺ = 5.0V, V ⁻ = -10V, 0V ≤ V _I ≤ 3.0V, C _L = 30 pF (See Figure 1)	R _L = 3.9 kΩ		50	ns
t _{PHL}	Propagation Delay to Low Level		R _L = 390Ω		50	ns

Note 1: "Absolute Maximum Ratings" are those values beyond which the safety of the device cannot be guaranteed. They are not meant to imply that the devices should be operated at these limits. The tables of "Electrical Characteristics" provide conditions for actual device operation.

Note 2: Unless otherwise specified Min/Max limits apply across the -55°C to +125°C temperature range. All typicals are given for V_{CC} = 5V and T_A = 25°C.

Note 3: All currents into device pins are positive; all currents out of device pins are negative. All voltages are referenced to ground unless otherwise specified.

Note 4: Only one output at a time should be shorted.

Note 5: Rating applies to ambient temperatures up to +125°C. Above 125°C ambient, derate linearly at 120°C/W.

Switching Time Test Circuit and Waveforms

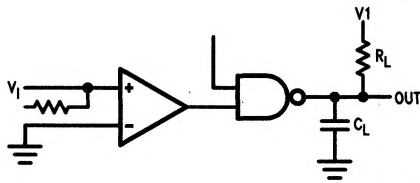

TL/F/9760-4

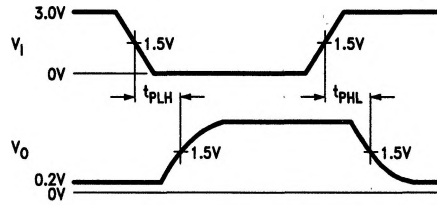

TL/F/9760-5

FIGURE 1

Equivalent Circuit

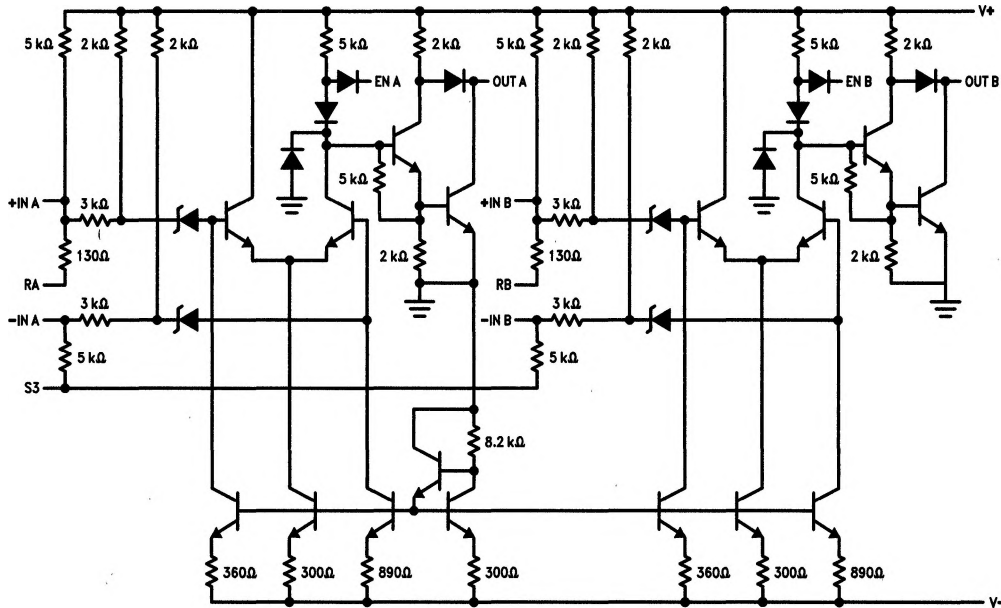

TL/F/9760-6

Typical Applications

When S3 is connected to V-, open inputs cause output to be high. When V+ = 5V, V- = -10V and S3 is connected to ground, open inputs cause output to be low.