

DS14C561

+ 3.3V-Powered 4 x 5 Driver/Receiver

General Description

The DS14C561 is a +3.3V-powered device that conforms to the new TIA/EIA-562 standard. This standard provides a faster, lower-power alternative to TIA/EIA-232-E (RS-232) Interfaces, while guaranteeing interoperability with TIA/EIA-232-E Interfaces. The DS14C561 is guaranteed to operate with a minimum supply voltage of +3V, while maintaining the TIA/EIA-562 output signal levels $\pm 3.7V$.

The DS14C561 features an internal DC-DC converter, with four external 1.0 μF capacitors to double and invert +3.3V to $\pm 6.6V$. The device also offers a shutdown mode that reduces supply current to 100 μA , making the part ideal for use in battery-powered or power-conscious applications.

Features

- Conforms to TIA/EIA-562
- Full AC Specifications
- Internal DC-DC converter
- Operates with a single +3.3V supply
- Low power requirement I_{CC} 6 mA max
- Shutdown mode I_{CX} 100 μA max
- Operates over 64 kbits/sec
- Receiver noise filtering
- TRI-STATE® receiver outputs
- Pin compatible with MAX561

Connection Diagram

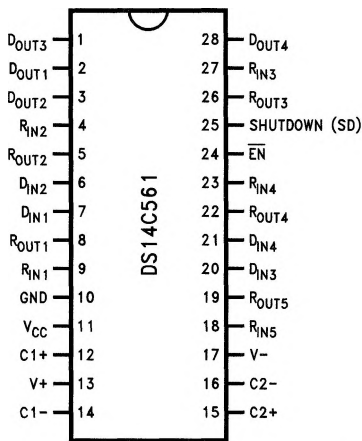

Order Number DS14C561WM
See NS Package Number M28B

TL/F/11363-1

Functional Diagram

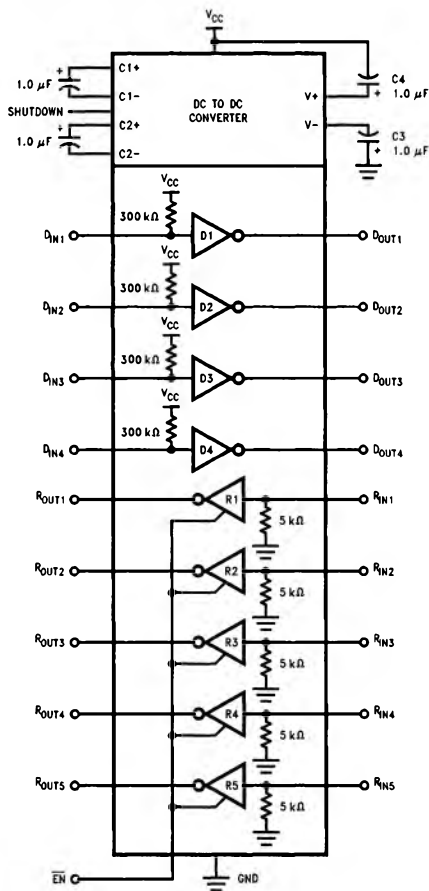

TL/F/11363-2

Absolute Maximum Ratings

If Military/Aerospace specified devices are required, please contact the National Semiconductor Sales Office/Distributors for availability and specifications.

Supply Voltage (V_{CC})	-0.3V to +6V
V+ Pin	($V_{CC} - 0.3V$) to +14V
V- Pin	+0.3V to -14V
Driver Input Voltage	-0.3V to ($V_{CC} + 0.3V$)
Driver Output Voltage	($V^+ + 0.3V$) to ($V^- - 0.3V$)
Receiver Input Voltage	$\pm 30V$
Receiver Output Voltage	-0.3V to ($V_{CC} + 0.3V$)
Junction Temperature	+150°C
Maximum Package Power Dissipation @ +25°C (Note 6)	
Wide SOIC (WM) Package	1520 mW

Storage Temperature Range	-65°C to +150°C
Lead Temperature (Soldering, 4 sec.)	+260°C
Short Circuit Duration (D_{OUT})	continuous

Recommended Operating Conditions

	Min	Max	Units
Supply Voltage (V_{CC})	3.0	3.6	V
Operating Free Air Temp. (T_A) DS14C561	0	+70	°C

Electrical Characteristics

$V_{CC} = +3.3V \pm 0.3V$, C1-C4 = 1 μF , $T_A = 0^\circ C$ to +70°C, unless otherwise specified (Note 2)

Symbol	Parameter	Conditions	Min	Typ	Max	Units	
DEVICE CHARACTERISTICS							
V+	Positive Power Supply	$R_L = 3\text{ k}\Omega$, C1-C4 = 1.0 μF	$D_{IN} = 0.4V$		6.0	V	
V-	Negative Power Supply		$D_{IN} = 2.4V$		-5.0	V	
I_{CC}	Supply Current (V_{CC})	No Load		3.5	6.0	mA	
I_{CX}	Supply Current Shutdown	$R_L = 3\text{ k}\Omega$, SD = V_{CC}		20	100	μA	
V_{IH}	High Level Enable Voltage		SD	2.0	V_{CC}	V	
V_{IL}	Low Level Enable Voltage		GND		0.4	V	
I_{IH}	High Level Enable Current			-10	+10	μA	
I_{IL}	Low Level Enable Current			-10	+10	μA	
DRIVER CHARACTERISTICS							
V_{IH}	High Level Input Voltage		D_{IN}	2.0	V_{CC}	V	
V_{IL}	Low Level Input Voltage			GND	0.4	V	
I_{IH}	High Level Input Current	$V_{IN} \geq 2.0V$		-10	+10	μA	
I_{IL}	Low Level Input Current	$V_{IN} \leq 0.4V$		-10	+10	μA	
		$V_{IN} = 0V$		-10	+10	μA	
V_{OH}	High Level Output Voltage	$R_L = 3\text{ k}\Omega$		3.7	5.0	13.2	V
V_{OL}	Low Level Output Voltage	3 Drivers Loaded		-13.2	-4.0	-3.7	V
V_{OH}	High Level Output Voltage	$R_L = 3\text{ k}\Omega$		3.7	4.8	13.2	V
V_{OL}	Low Level Output Voltage	4 Drivers Loaded, $V_{CC} = +3.3V$		-13.2	-4.2	-3.7	V
I_{OS}^+	Output High Short Circuit Current	$V_O = 0V$, $V_{IN} = 0.4V$		-20	-10	-2	mA
I_{OS}^-	Output Low Short Circuit Current	$V_O = 0V$, $V_{IN} = 2.0V$		2.0	8.0	20	mA
R_O	Output Resistance	$-2V \leq V_O \leq +2V$, $V_{CC} = GND = 0V$		300			Ω
RECEIVER CHARACTERISTICS							
V_{TH}	Input High Threshold Voltage			1.3	2.0	V	
V_{TL}	Input Low Threshold Voltage			0.4	1.0	V	
V_{HY}	Hysteresis			0.05	0.3	V	
R_{IN}	Input Resistance			3.0	4.5	7.0	k Ω

Electrical Characteristics (Continued)
 $V_{CC} = +3.3V \pm 0.3V$, $C1-C4 = 1 \mu F$, $T_A = 0^\circ C$ to $+70^\circ C$, unless otherwise specified (Note 2)

Symbol	Parameter	Conditions	Min	Typ	Max	Units	
RECEIVER CHARACTERISTICS (Continued)							
I_{IN}	Input Current	$V_{IN} = +15V$	2.14		5.0	mA	
		$V_{IN} = +3V$	0.43		1.0	mA	
		$V_{IN} = -3V$	-1.0		-0.43	mA	
		$V_{IN} = -15V$	-5.0		-2.14	mA	
V_{OH}	High Level Output Voltage	$V_{IN} = -3V, I_O = -200 \mu A$	2.6	3.0		V	
V_{OL}	Low Level Output Voltage	$V_{IN} = +3V, I_O = +1.6 mA$		0.2	0.4	V	
V_{IH}	High Level Input Voltage	EN	2.0		V_{CC}	V	
V_{IL}	Low Level Input Voltage		GND		0.4	V	
I_{IH}	High Level Input Current		$V_{IN} \geq 2.0V$	-10		+10	μA
I_{IL}	Low Level Input Current		$V_{IN} \leq 0.4V$	-10		+10	μA
I_{OZ}	Output Leakage Current	EN = V_{CC} , $0V \leq R_{OUT} \leq V_{CC}$	-10		+10	μA	

Switching Characteristics
 $V_{CC} = +3.3V \pm 0.3V$, $C1-C4 = 1 \mu F$, $T_A = 0^\circ C$ to $+70^\circ C$, unless otherwise specified (Note 4)

Symbol	Parameter	Conditions	Min	Typ	Max	Units
DRIVER CHARACTERISTICS						
t_{PLH}	Propagation Delay LOW to HIGH	$R_L = 3 k\Omega$ $C_L = 50 pF$ (Figures 1 and 2)		1.0	4.0	μs
t_{PHL}	Propagation Delay HIGH to LOW			0.8	4.0	μs
t_{SK}	Skew $ t_{PLH} - t_{PHL} $			0.2	1.0	μs
SR1	Output Slew Rate	$R_L = 3 k\Omega$ to $7 k\Omega$, $C_L = 50 pF$			30	V/ μs
SR2	Output Slew Rate	$R_L = 3 k\Omega$, $C_L = 2500 pF$, $f = 10 kHz$			30	V/ μs
t_r, t_f	Output Rise, Fall Time (Note 7)	$V_{CC} = 3.3V$ $R_L = 3 k\Omega$, $C_L = 2500 pF$, $f = 10 kHz$	0.2	2.7	3.1	μs
		$R_L = 3 k\Omega$, $C_L = 1000 pF$, $f = 32 kHz$	0.2	1.7	2.1	μs

RECEIVER CHARACTERISTICS

t_{PLH}	Propagation Delay LOW to HIGH	Input Pulse Width $> 10 \mu s$ $C_L = 150 pF$ (Figures 3 and 4)		3.7	9.0	μs
t_{PHL}	Propagation Delay HIGH to LOW			4.7	9.0	μs
t_{SK}	Skew $ t_{PLH} - t_{PHL} $			1.0	3.0	μs
t_{PLZ}		(Figures 5 and 7)		0.2		μs
t_{PZL}				1.2		μs
t_{PHZ}		(Figures 5 and 6)		0.4		μs
t_{PZH}				1.2		μs
t_{NW}	Noise Pulse Width Rejected	(Figures 3 and 4)		4.0	1.0	μs

Note 1: "Absolute Maximum Ratings" are those values beyond which the safety of the device cannot be guaranteed. They are not meant to imply that the devices should be operated at these limits. The tables of "Electrical Characteristics" specify conditions for device operation.

Note 2: Current into device pins is defined as positive. Current out of device pins is defined as negative. All voltages are referenced to ground unless otherwise specified.

Note 3: I_{OS}^+ and I_{OS}^- values are for one output at a time. If more than one output is shorted simultaneously, the device power dissipation may be exceeded.

Note 4: Receiver AC input waveform for test purposes: $t_r = t_f = 200 ns$, $V_{IH} = 3V$, $V_{IL} = -3V$, $f = 32 kHz$ (64 kbits/sec). Driver AC input waveform for test purposes: $t_r = t_f = \leq 10 ns$, $V_{IH} = 3V$, $V_{IL} = 0V$, $f = 32 kHz$ (64 kbits/sec).

Note 5: All typicals are given for $V_{CC} = 3.3V$ and $T_A = +25^\circ C$.

Note 6: Ratings apply to ambient temperature at $+25^\circ C$. Above this temperature derate: WM package 14.3 mW/ $^\circ C$.

Note 7: Rise and Fall Times (t_r, t_f) are measured between the $\pm 3.3V$ levels on the driver output. One output switching.

Parameter Measurement Information

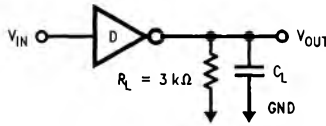

TL/F/11363-3

FIGURE 1. Driver Load Circuit

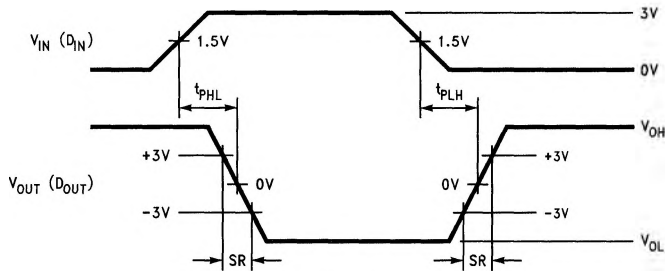

TL/F/11363-4

FIGURE 2. Driver Switching Waveform

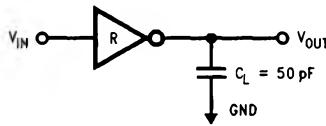

TL/F/11363-5

FIGURE 3. Receiver Load Circuit

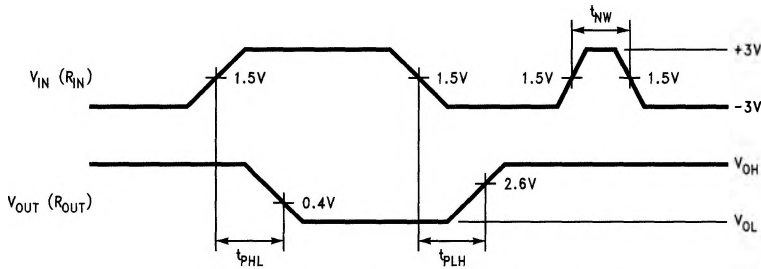

TL/F/11363-6

FIGURE 4. Receiver Propagation Delays and Noise Rejection

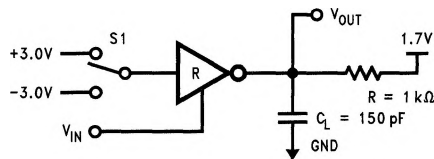

TL/F/11363-7

FIGURE 5. Receiver Disable Load Circuit

Parameter Measurement Information (Continued)

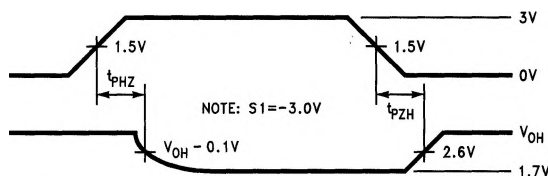

FIGURE 6. Receiver TRI-STATE® Delay Timing (t_{PHZ} , t_{PZH})

TL/F/11363-8

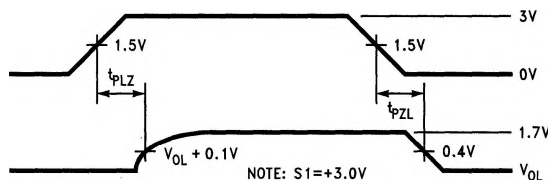

FIGURE 7. Receiver TRI-STATE® Delay Timing (t_{PLZ} , t_{PZL})

TL/F/11363-9

Pin Descriptions

V_{CC} (pin 11)—Power supply pin for the device, +3.3V ±0.3V.

V⁺ (pin 13)—Positive supply for drivers. Recommended external capacitor: C4 = 1 μF. This supply is not intended to be loaded externally.

V⁻ (pin 17)—Negative supply for drivers. Recommended external capacitor: C3 = 1 μF. This supply is not intended to be loaded externally.

C1⁺, C1⁻ (pins 12 and 14)—External capacitor connection pins. Recommended capacitor: 1 μF.

C2⁺, C2⁻ (pins 15 and 16)—External capacitor connection pins. Recommended capacitor: 1 μF.

EN (pin 24)—Controls the Receiver output TRI-STATE® Circuit. A HIGH level on this pin will disable the Receiver Output.

SHUTDOWN (SD) (pin 25)—A High on the SHUTDOWN pin will lower the total I_{CC} current to less than 100 μA. Providing a low power state.

D_{IN} 1-4 (pins 7, 6, 20 and 21)—Inputs of unused drivers may be left open, an internal pull-up resistor pulls input to V_{CC}. Output will be LOW for open inputs. (300 kΩ minimum, typically 3.3 MΩ)

D_{OUT} 1-4 (pins 2, 3, 1 and 28)—Driver output pins conform to TIA/EIA-562 levels.

R_{IN} 1-5 (pins 9, 4, 27, 23 and 18)—Receiver input pins accept TIA/EIA-562 input voltages (±15V). Receivers feature a noise filter and guaranteed hysteresis of 50 mV. Unused receiver input pins may be left open. Internal input resistor (5 kΩ) pulls input LOW, providing a failsafe HIGH output.

R_{OUT} 1-5 (pins 8, 5, 26, 22 and 19)—Receiver output pins generate a maximum V_{OL} of 0.4V given an I_O of 1.6 mA and a minimum V_{OH} of 2.6V given an I_O of -200 μA.

GND (pin 10)—Ground pin.