

## DC MOTOR DRIVER IC

 Check for Samples: [DRV8840](#)

### FEATURES

- **Single H-Bridge Current-Control Motor Driver**
  - Drives One DC Motor
  - Brake Mode
  - Five-Bit Winding Current Control Allows Up to 32 Current Levels
  - Low MOSFET On-Resistance
- **5-A Maximum Drive Current at 24 V, 25°C**
- **Built-In 3.3-V Reference Output**
- **Industry-Standard Parallel Digital Control Interface**

- **8.2-V to 45-V Operating Supply Voltage Range**
- **Thermally Enhanced Surface Mount Package**

### APPLICATIONS

- **Printers**
- **Scanners**
- **Office Automation Machines**
- **Gaming Machines**
- **Factory Automation**
- **Robotics**

### DESCRIPTION

The DRV8840 provides an integrated motor driver solution for printers, scanners, and other automated equipment applications. The device has one H-bridge driver, and is intended to drive one DC motor. The output driver block for each consists of N-channel power MOSFET's configured as full H-bridges to drive the motor windings. The DRV8840 can supply up to 5-A peak or 3.5-A output current (with proper heatsinking at 24 V and 25°C).

A simple parallel digital control interface is compatible with industry-standard devices. Decay mode is programmable to allow braking or coasting of the motor when disabled.

Internal shutdown functions are provided for over current protection, short circuit protection, under voltage lockout and overtemperature.

The DRV8840 is available in a 28-pin HTSSOP package with PowerPAD™ (Eco-friendly: RoHS & no Sb/Br).

### ORDERING INFORMATION<sup>(1)</sup>

| T <sub>A</sub> | PACKAGE <sup>(2)</sup>   |              | ORDERABLE PART NUMBER | TOP-SIDE MARKING |
|----------------|--------------------------|--------------|-----------------------|------------------|
| –40°C to 85°C  | PowerPAD™ (HTSSOP) - PWP | Reel of 2000 | DRV8840PWPR           | 8840             |

(1) For the most current packaging and ordering information, see the Package Option Addendum at the end of this document, or see the TI web site at [www.ti.com](http://www.ti.com).

(2) Package drawings, thermal data, and symbolization are available at [www.ti.com/packaging](http://www.ti.com/packaging).



Please be aware that an important notice concerning availability, standard warranty, and use in critical applications of Texas Instruments semiconductor products and disclaimers thereto appears at the end of this data sheet.

PowerPAD is a trademark of Texas Instruments.

DEVICE INFORMATION  
Functional Block Diagram

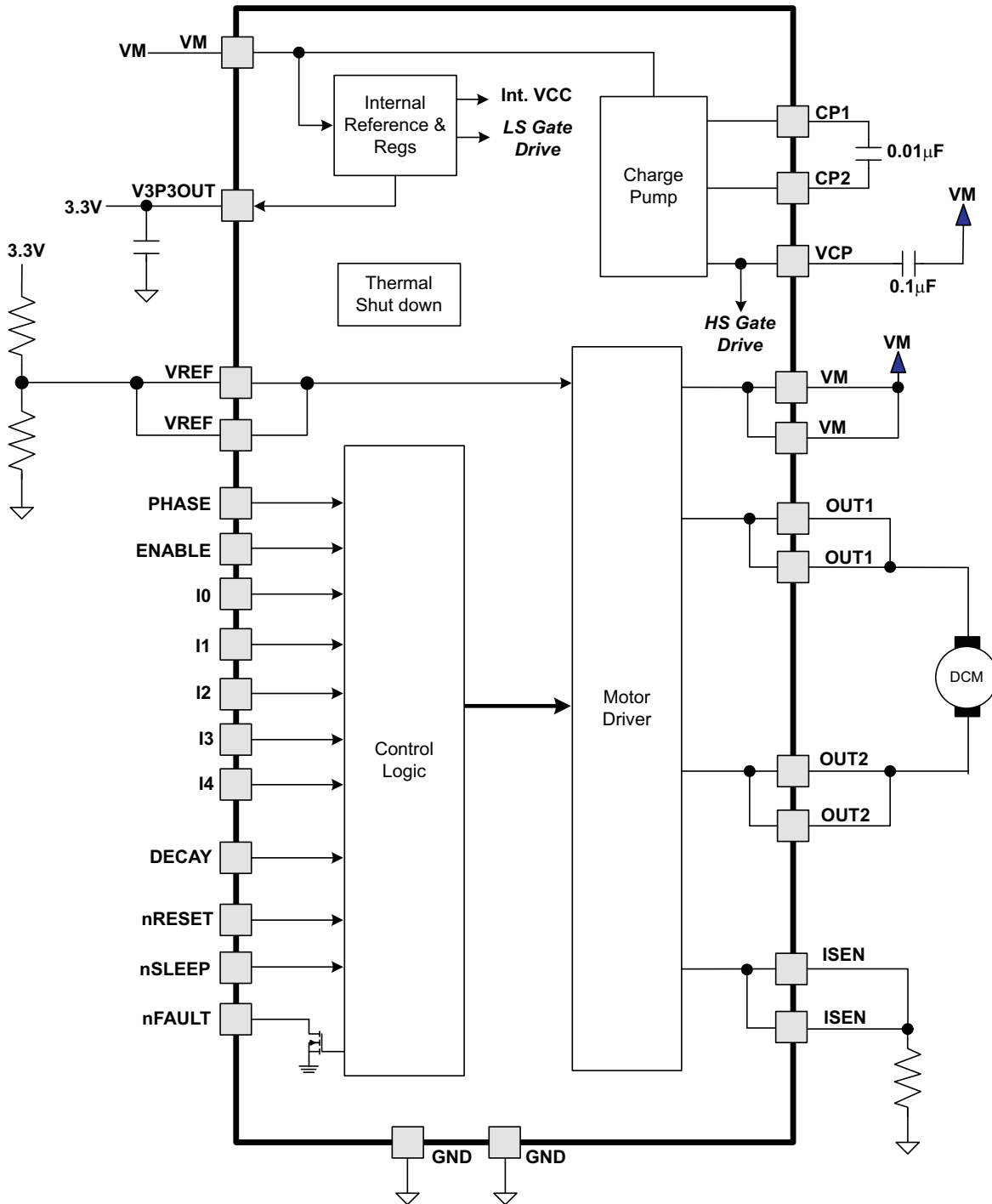

**Table 1. TERMINAL FUNCTIONS**

| NAME                    | PIN    | I/O <sup>(1)</sup> | DESCRIPTION                  | EXTERNAL COMPONENTS OR CONNECTIONS   |
|-------------------------|--------|--------------------|------------------------------|--|
| <b>POWER AND GROUND</b> |        |                    |                              |  |
| GND                     | 14, 28 | -                  | Device ground                |  |
| VM                      | 4, 11  | -                  | Bridge A power supply        | Connect to motor supply (8.2 - 45 V). Both pins must be connected to same supply.                  |
| V3P3OUT                 | 15     | O                  | 3.3-V regulator output       | Bypass to GND with a 0.47- $\mu$ F, 6.3-V ceramic capacitor. Can be used to supply VREF.           |
| CP1                     | 1      | IO                 | Charge pump flying capacitor | Connect a 0.01- $\mu$ F 50-V capacitor between CP1 and CP2.  |
| CP2                     | 2      | IO                 | Charge pump flying capacitor |  |
| VCP                     | 3      | IO                 | High-side gate drive voltage | Connect a 0.1- $\mu$ F 16-V ceramic capacitor to VM.   |
| <b>CONTROL</b>          |        |                    |                              |  |
| PHASE                   | 20     | I                  | Bridge phase (direction)     | Logic high sets OUT1 high, OUT2 low. Internal pulldown.  |
| ENBL                    | 21     | I                  | Bridge enable                | Logic high to enable H-bridge. Internal pulldown.  |
| I0                      | 23     | I                  | Current set inputs           | Sets winding current as a percentage of full-scale. Internal pulldown.                             |
| I1                      | 24     | I                  |                              |  |
| I2                      | 25     | I                  |                              |  |
| I3                      | 26     | I                  |                              |  |
| I4                      | 27     | I                  |                              |  |
| DECAY                   | 19     | I                  | Decay (brake) mode           | Low = brake (slow decay), high = coast (fast decay). Internal pulldown and pullup.                 |
| nRESET                  | 16     | I                  | Reset input                  | Active-low reset input initializes the logic and disables the H-bridge outputs. Internal pulldown. |
| nSLEEP                  | 17     | I                  | Sleep mode input             | Logic high to enable device, logic low to enter low-power sleep mode. Internal pulldown.           |
| VREF                    | 12,13  | I                  | Current set reference input  | Reference voltage for winding current set. Both pins must be connected together on the PCB.        |
| <b>STATUS</b>           |        |                    |                              |  |
| nFAULT                  | 18     | OD                 | Fault                        | Logic low when in fault condition (overtemp, overcurrent)  |
| <b>OUTPUT</b>           |        |                    |                              |  |
| ISEN                    | 6, 9   | IO                 | Bridge ground / Isense       | Connect to current sense resistor. Both pins must be connected together on the PCB.                |
| OUT1                    | 5, 10  | O                  | Bridge output 1              | Connect to motor winding. Both pins must be connected together on the PCB.                         |
| OUT2                    | 7, 8   | O                  | Bridge output 2              | Connect to motor winding. Both pins must be connected together on the PCB.                         |

(1) Directions: I = input, O = output, OZ = tri-state output, OD = open-drain output, IO = input/output

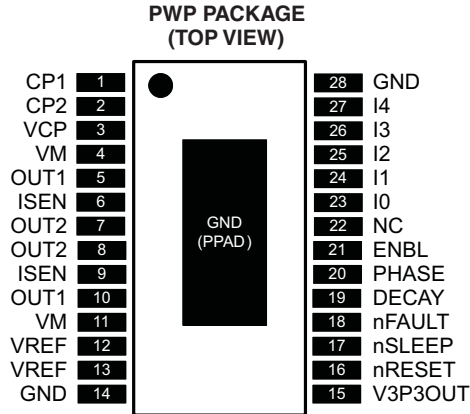

### ABSOLUTE MAXIMUM RATINGS

over operating free-air temperature range (unless otherwise noted) <sup>(1)</sup> <sup>(2)</sup>

|                  |  | VALUE                         | UNIT |
|------------------|--|-------------------------------|------|
| VMx              | Power supply voltage range                           | −0.3 to 47                    | V    |
|                  | Digital pin voltage range                            | −0.5 to 7                     | V    |
| VREF             | Input voltage  | −0.3 to 4                     | V    |
|                  | ISENSEx pin voltage                                  | −0.3 to 0.8                   | V    |
|                  | Peak motor drive output current, $t < 1 \mu\text{s}$ | Internally limited            | A    |
|                  | Continuous motor drive output current <sup>(3)</sup> | 5                             | A    |
|                  | Continuous total power dissipation                   | See Dissipation Ratings table |      |
| T <sub>J</sub>   | Operating virtual junction temperature range         | −40 to 150                    | °C   |
| T <sub>A</sub>   | Operating ambient temperature range                  | −40 to 85                     | °C   |
| T <sub>stg</sub> | Storage temperature range                            | −60 to 150                    | °C   |

- (1) Stresses beyond those listed under absolute maximum ratings may cause permanent damage to the device. These are stress ratings only, and functional operation of the device at these or any other conditions beyond those indicated under recommended operating conditions is not implied. Exposure to absolute–maximum–rated conditions for extended periods may affect device reliability.
- (2) All voltage values are with respect to network ground terminal.
- (3) Power dissipation and thermal limits must be observed.

## THERMAL INFORMATION

| THERMAL METRIC <sup>(1)</sup> |   | DRV8840 | UNITS |
|-------------------------------|---|---------|-------|
|                               |   | PWP     |       |
|                               |   | 28 PINS |       |
| $\theta_{JA}$                 | Junction-to-ambient thermal resistance <sup>(2)</sup>       | 31.6    | °C/W  |
| $\theta_{JcTop}$              | Junction-to-case (top) thermal resistance <sup>(3)</sup>    | 15.9    |       |
| $\theta_{JB}$                 | Junction-to-board thermal resistance <sup>(4)</sup>         | 5.6     |       |
| $\psi_{JT}$                   | Junction-to-top characterization parameter <sup>(5)</sup>   | 0.2     |       |
| $\psi_{JB}$                   | Junction-to-board characterization parameter <sup>(6)</sup> | 5.5     |       |
| $\theta_{JcBot}$              | Junction-to-case (bottom) thermal resistance <sup>(7)</sup> | 1.4     |       |

- (1) For more information about traditional and new thermal metrics, see the *IC Package Thermal Metrics* application report, [SPRA953](#).
- (2) The junction-to-ambient thermal resistance under natural convection is obtained in a simulation on a JEDEC-standard, high-K board, as specified in JESD51-7, in an environment described in JESD51-2a.
- (3) The junction-to-case (top) thermal resistance is obtained by simulating a cold plate test on the package top. No specific JEDEC-standard test exists, but a close description can be found in the ANSI SEMI standard G30-88.
- (4) The junction-to-board thermal resistance is obtained by simulating in an environment with a ring cold plate fixture to control the PCB temperature, as described in JESD51-8.
- (5) The junction-to-top characterization parameter,  $\psi_{JT}$ , estimates the junction temperature of a device in a real system and is extracted from the simulation data for obtaining  $\theta_{JA}$ , using a procedure described in JESD51-2a (sections 6 and 7).
- (6) The junction-to-board characterization parameter,  $\psi_{JB}$ , estimates the junction temperature of a device in a real system and is extracted from the simulation data for obtaining  $\theta_{JA}$ , using a procedure described in JESD51-2a (sections 6 and 7).
- (7) The junction-to-case (bottom) thermal resistance is obtained by simulating a cold plate test on the exposed (power) pad. No specific JEDEC standard test exists, but a close description can be found in the ANSI SEMI standard G30-88.

## RECOMMENDED OPERATING CONDITIONS

over operating free-air temperature range (unless otherwise noted)

|            |   | MIN | NOM | MAX | UNIT |
|------------|---|-----|-----|-----|------|
| $V_M$      | Motor power supply voltage range <sup>(1)</sup> | 8.2 |     | 45  | V    |
| $V_{REF}$  | VREF input voltage <sup>(2)</sup>               | 1   |     | 3.5 | V    |
| $I_{V3P3}$ | V3P3OUT load current                            | 0   |     | 1   | mA   |
| $f_{PWM}$  | Externally applied PWM frequency                | 0   |     | 100 | kHz  |

- (1) All  $V_M$  pins must be connected to the same supply voltage.
- (2) Operational at VREF between 0 V and 1 V, but accuracy is degraded.

## ELECTRICAL CHARACTERISTICS

over operating free-air temperature range (unless otherwise noted)

| PARAMETER                                |  | TEST CONDITIONS   | MIN | TYP  | MAX      | UNIT             |
|--|--|---|-----|------|----------|------------------|
| <b>POWER SUPPLIES</b>                    |  |   |     |      |          |                  |
| $I_{VM}$                                 | VM operating supply current                          | $V_M = 24\text{ V}$ , $f_{PWM} < 50\text{ kHz}$                     |     | 5    | 8        | mA               |
| $I_{VMQ}$                                | VM sleep mode supply current                         | $V_M = 24\text{ V}$   |     | 10   | 20       | $\mu\text{A}$    |
| $V_{UVLO}$                               | VM undervoltage lockout voltage                      | $V_M$ rising  |     | 7.8  | 8.2      | V                |
| <b>V3P3OUT REGULATOR</b>                 |  |   |     |      |          |                  |
| $V_{3P3}$                                | V3P3OUT voltage                                      | $I_{OUT} = 0$ to 1 mA   | 3.2 | 3.3  | 3.4      | V                |
| <b>LOGIC-LEVEL INPUTS</b>                |  |   |     |      |          |                  |
| $V_{IL}$                                 | Input low voltage                                    |   |     | 0.6  | 0.7      | V                |
| $V_{IH}$                                 | Input high voltage                                   |   | 2.2 |      | 5.25     | V                |
| $V_{HYS}$                                | Input hysteresis                                     |   | 0.3 | 0.45 | 0.6      | V                |
| $I_{IL}$                                 | Input low current                                    | $V_{IN} = 0$  | -20 |      | 20       | $\mu\text{A}$    |
| $I_{IH}$                                 | Input high current                                   | $V_{IN} = 3.3\text{ V}$   |     | 33   | 100      | $\mu\text{A}$    |
| $R_{PD}$                                 | Internal pulldown resistance                         |   |     | 100  |          | k $\Omega$       |
| <b>nFAULT OUTPUT (OPEN-DRAIN OUTPUT)</b> |  |   |     |      |          |                  |
| $V_{OL}$                                 | Output low voltage                                   | $I_O = 5\text{ mA}$   |     |      | 0.5      | V                |
| $I_{OH}$                                 | Output high leakage current                          | $V_O = 3.3\text{ V}$  |     |      | 1        | $\mu\text{A}$    |
| <b>DECAY INPUT</b>                       |  |   |     |      |          |                  |
| $V_{IL}$                                 | Input low threshold voltage                          | For slow decay (brake) mode   | 0   |      | 0.8      | V                |
| $V_{IH}$                                 | Input high threshold voltage                         | For fast decay (coast) mode   | 2   |      |          | V                |
| $I_{IN}$                                 | Input current  |   |     |      | $\pm 40$ | $\mu\text{A}$    |
| $R_{PU}$                                 | Internal pullup resistance                           |   |     | 130  |          | k $\Omega$       |
| $R_{PD}$                                 | Internal pulldown resistance                         |   |     | 80   |          | k $\Omega$       |
| <b>H-BRIDGE FETS</b>                     |  |   |     |      |          |                  |
| $R_{DS(ON)}$                             | HS FET on resistance                                 | $V_M = 24\text{ V}$ , $I_O = 1\text{ A}$ , $T_J = 25^\circ\text{C}$ |     | 0.1  |          | $\Omega$         |
|  |  | $V_M = 24\text{ V}$ , $I_O = 1\text{ A}$ , $T_J = 85^\circ\text{C}$ |     | 0.13 | 0.16     |                  |
| $R_{DS(ON)}$                             | LS FET on resistance                                 | $V_M = 24\text{ V}$ , $I_O = 1\text{ A}$ , $T_J = 25^\circ\text{C}$ |     | 0.1  |          | $\Omega$         |
|  |  | $V_M = 24\text{ V}$ , $I_O = 1\text{ A}$ , $T_J = 85^\circ\text{C}$ |     | 0.13 | 0.16     |                  |
| $I_{OFF}$                                | Off-state leakage current                            |   | -40 |      | 40       | $\mu\text{A}$    |
| <b>MOTOR DRIVER</b>                      |  |   |     |      |          |                  |
| $f_{PWM}$                                | Internal current control PWM frequency               |   |     | 50   |          | kHz              |
| $t_{BLANK}$                              | Current sense blanking time                          |   |     | 3.75 |          | $\mu\text{s}$    |
| $t_R$                                    | Rise time  |   | 30  |      | 200      | ns               |
| $t_F$                                    | Fall time  |   | 30  |      | 200      | ns               |
| <b>PROTECTION CIRCUITS</b>               |  |   |     |      |          |                  |
| $I_{OCP}$                                | Overcurrent protection trip level                    |   | 6   |      |          | A                |
| $t_{TSD}$                                | Thermal shutdown temperature                         | Die temperature   | 150 | 160  | 180      | $^\circ\text{C}$ |
| <b>CURRENT CONTROL</b>                   |  |   |     |      |          |                  |
| $I_{REF}$                                | VREF input current                                   | $V_{REF} = 3.3\text{ V}$  | -3  |      | 3        | $\mu\text{A}$    |
| $V_{TRIP}$                               | ISENSE trip voltage                                  | $V_{REF} = 3.3\text{ V}$ , 100% current setting                     | 635 | 660  | 685      | mV               |
| $\Delta I_{TRIP}$                        | Current trip accuracy (relative to programmed value) | $V_{REF} = 3.3\text{ V}$ , 5% current setting                       | -25 |      | 25       | %                |
|  |  | $V_{REF} = 3.3\text{ V}$ , 10% - 34% current setting                | -15 |      | 15       |                  |
|  |  | $V_{REF} = 3.3\text{ V}$ , 38% - 67% current setting                | -10 |      | 10       |                  |
|  |  | $V_{REF} = 3.3\text{ V}$ , 71% - 100% current setting               | -5  |      | 5        |                  |
| $A_{ISENSE}$                             | Current sense amplifier gain                         | Reference only  |     | 5    |          | V/V              |

## FUNCTIONAL DESCRIPTION

### PWM Motor Driver

The DRV8840 contains one H-bridge motor driver with current-control PWM circuitry. A block diagram of the motor control circuitry is shown in [Figure 1](#).

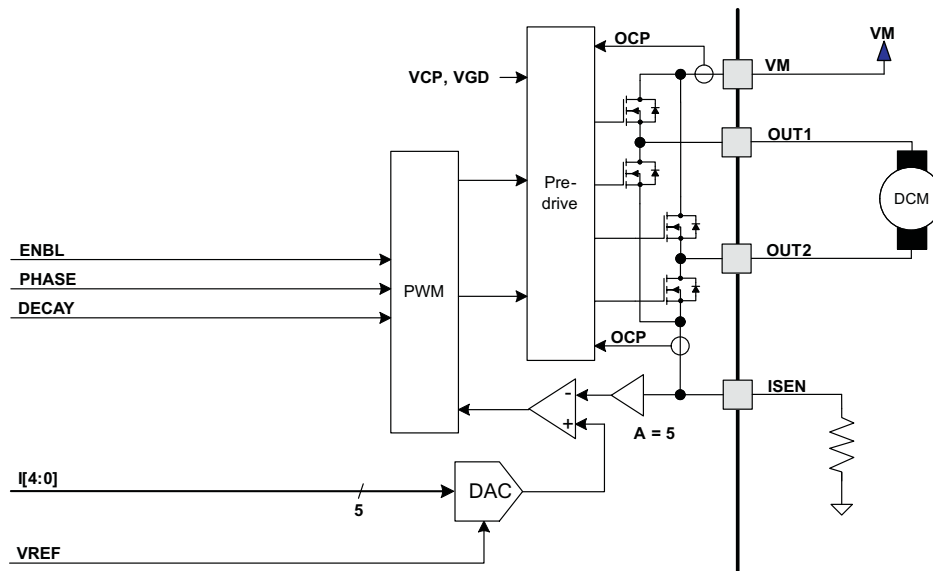

Figure 1. Motor Control Circuitry

Note that there are multiple VM, ISEN, OUT, and VREF pins. All like-named pins must be connected together on the PCB.

### Bridge Control

The PHASE input pin controls the direction of current flow through the H-bridge, and hence the direction of rotation of a DC motor. The ENBL input pin enables the H-bridge outputs when active high, and can also be used for PWM speed control of the motor. Note that the state of the DECAY pin selects the behavior of the bridge when ENBL = 0, allowing the selection of slow decay (brake) or fast decay (coast). [Table 2](#) shows the logic.

Table 2. H-Bridge Logic

| DECAY | ENBL | PHASE | OUT1 | OUT2 |
|-------|------|-------|------|------|
| 0     | 0    | X     | L    | L    |
| 1     | 0    | X     | Z    | Z    |
| X     | 1    | 1     | H    | L    |
| X     | 1    | 0     | L    | H    |

The control inputs have internal pulldown resistors of approximately 100 kΩ.

### Current Regulation

The maximum current through the motor winding is regulated by a fixed-frequency PWM current regulation, or current chopping. When the H-bridge is enabled, current rises through the winding at a rate dependent on the DC voltage and inductance of the winding. Once the current hits the current chopping threshold, the bridge disables the current until the beginning of the next PWM cycle.

For DC motors, current regulation is used to limit the start-up and stall current of the motor. Speed control is typically performed by providing an external PWM signal to the ENBLx input pins.

If the current regulation feature is not needed, it can be disabled by connecting the ISENSE pins directly to ground and the VREF pins to V3P3.

The PWM chopping current is set by a comparator which compares the voltage across a current sense resistor connected to the ISEN pin, multiplied by a factor of 5, with a reference voltage. The reference voltage is input from the VREF pin, and is scaled by a 5-bit DAC that allows current settings of zero to 100% in an approximately sinusoidal sequence.

The full-scale (100%) chopping current is calculated in [Equation 1](#).

$$I_{CHOP} = \frac{V_{REFX}}{5 \cdot R_{ISENSE}} \tag{1}$$

Example:

If a 0.25-Ω sense resistor is used and the VREFx pin is 2.5 V, the full-scale (100%) chopping current will be 2.5 V / (5 x 0.25 Ω) = 2 A.

Five input pins (I0 - I4) are used to scale the current in the bridge as a percentage of the full-scale current set by the VREF input pin and sense resistance. The I0 - I4 pins have internal pulldown resistors of approximately 100 kΩ. The function of the pins is shown in [Table 3](#).

**Table 3. Pin Functions**

| I[4..0] | RELATIVE CURRENT<br>(% FULL-SCALE CHOPPING CURRENT) |
|---------|---|
| 0x00h   | 0%  |
| 0x01h   | 5%  |
| 0x02h   | 10%   |
| 0x03h   | 15%   |
| 0x04h   | 20%   |
| 0x05h   | 24%   |
| 0x06h   | 29%   |
| 0x07h   | 34%   |
| 0x08h   | 38%   |
| 0x09h   | 43%   |
| 0x0Ah   | 47%   |
| 0x0Bh   | 51%   |
| 0x0Ch   | 56%   |
| 0x0Dh   | 60%   |
| 0x0Eh   | 63%   |
| 0x0Fh   | 67%   |
| 0x10h   | 71%   |
| 0x11h   | 74%   |
| 0x12h   | 77%   |
| 0x13h   | 80%   |
| 0x14h   | 83%   |
| 0x15h   | 86%   |
| 0x16h   | 88%   |



**Table 3. Pin Functions (continued)**

| I[4..0] | RELATIVE CURRENT<br>(% FULL-SCALE CHOPPING CURRENT) |
|---------|---|
| 0x17h   | 90%   |
| 0x18h   | 92%   |
| 0x19h   | 94%   |
| 0x1Ah   | 96%   |
| 0x1Bh   | 97%   |
| 0x1Ch   | 98%   |
| 0x1Dh   | 99%   |
| 0x1Eh   | 100%  |
| 0x1Fh   | 100%  |

**Decay Mode and Braking**

During PWM current chopping, the H-bridge is enabled to drive current through the motor winding until the PWM current chopping threshold is reached. This is shown in Figure 2 as case 1. The current flow direction shown indicates the state when the xENBL pin is high.

Once the chopping current threshold is reached, the H-bridge can operate in two different states, fast decay or slow decay.

In fast decay mode, once the PWM chopping current level has been reached, the H-bridge reverses state to allow winding current to flow in a reverse direction. As the winding current approaches zero, the bridge is disabled to prevent any reverse current flow. Fast decay mode is shown in Figure 2 as case 2.

In slow decay mode, winding current is re-circulated by enabling both of the low-side FETs in the bridge. This is shown in Figure 2 as case 3.

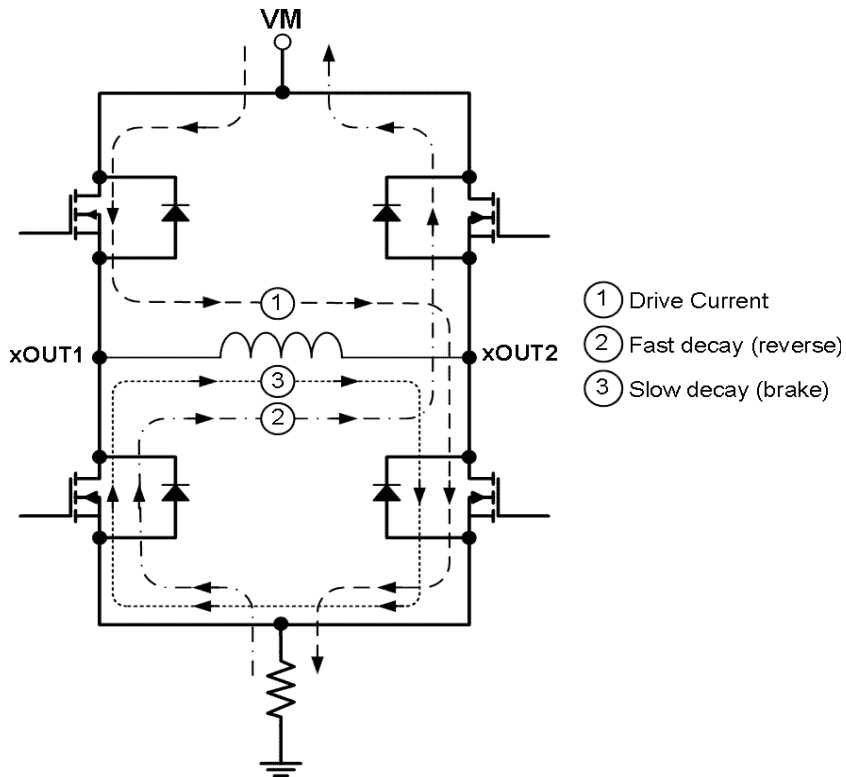

**Figure 2. Decay Mode**

The DRV8840 supports fast decay and slow decay mode. Slow or fast decay mode is selected by the state of the DECAY pin - logic low selects slow decay, and logic high sets fast decay mode. The DECAY pin has both an internal pullup resistor of approximately 130 k $\Omega$  and an internal pulldown resistor of approximately 80 k $\Omega$ . This sets the mixed decay mode if the pin is left open or undriven.

DECAY mode also affects the operation of the bridge when it is disabled (by taking the ENBL pin inactive). This applies if the ENABLE input is being used for PWM speed control of the motor, or if it is simply being used to start and stop motor rotation.

If the DECAY pin is high (fast decay), when the bridge is disabled fast decay mode will be entered until the current through the bridge reaches zero. Once the current is at zero, the bridge is disabled to prevent the motor from reversing direction. This allows the motor to coast to a stop.

If the DECAY pin is low (slow decay), both low-side FETs will be turned on when ENBL is made inactive. This essentially shorts out the back EMF of the motor, causing the motor to brake, and stop quickly. The low-side FETs will stay in the ON state even after the current reaches zero.

### Blanking Time

After the current is enabled in an H-bridge, the voltage on the xISEN pin is ignored for a fixed period of time before enabling the current sense circuitry. This blanking time is fixed at 3.75  $\mu$ s. Note that the blanking time also sets the minimum on time of the PWM.

### nRESET and nSLEEP Operation

The nRESET pin, when driven active low, resets the internal logic. It also disables the H-bridge driver. All inputs are ignored while nRESET is active.

Driving nSLEEP low will put the device into a low power sleep state. In this state, the H-bridges are disabled, the gate drive charge pump is stopped, the V3P3OUT regulator is disabled, and all internal clocks are stopped. In this state all inputs are ignored until nSLEEP returns inactive high. When returning from sleep mode, some time (approximately 1 ms) needs to pass before the motor driver becomes fully operational. Note that nRESET and nSLEEP have internal pulldown resistors of approximately 100 k $\Omega$ . These signals need to be driven to logic high for device operation.

### Protection Circuits

The DRV8840 is fully protected against undervoltage, overcurrent and overtemperature events.

#### Overcurrent Protection (OCP)

An analog current limit circuit on each FET limits the current through the FET by removing the gate drive. If this analog current limit persists for longer than the OCP time, all FETs in the H-bridge will be disabled and the nFAULT pin will be driven low. The device will remain disabled until either nRESET pin is applied, or VM is removed and re-applied.

Overcurrent conditions on both high and low side devices; i.e., a short to ground, supply, or across the motor winding will all result in an overcurrent shutdown. Note that overcurrent protection does not use the current sense circuitry used for PWM current control, and is independent of the I<sub>SENSE</sub> resistor value or VREF voltage.

#### Thermal Shutdown (TSD)

If the die temperature exceeds safe limits, all FETs in the H-bridge will be disabled and the nFAULT pin will be driven low. Once the die temperature has fallen to a safe level operation will automatically resume.

#### Undervoltage Lockout (UVLO)

If at any time the voltage on the VM pins falls below the undervoltage lockout threshold voltage, all circuitry in the device will be disabled and internal logic will be reset. Operation will resume when V<sub>M</sub> rises above the UVLO threshold.

## THERMAL INFORMATION

### Thermal Protection

The DRV8840 has thermal shutdown (TSD) as described above. If the die temperature exceeds approximately 150°C, the device will be disabled until the temperature drops to a safe level.

Any tendency of the device to enter TSD is an indication of either excessive power dissipation, insufficient heatsinking, or too high an ambient temperature.

### Power Dissipation

Average power dissipation in the DRV8840 when running a DC motor can be roughly estimated by: [Equation 2](#).

$$P = 2 \cdot R_{DS(ON)} \cdot (I_{OUT})^2 \quad (2)$$

where P is the power dissipation of one H-bridge,  $R_{DS(ON)}$  is the resistance of each FET, and  $I_{OUT}$  is the RMS output current being applied to each winding.  $I_{OUT}$  is equal to the average current drawn by the DC motor. Note that at start-up and fault conditions this current is much higher than normal running current; these peak currents and their duration also need to be taken into consideration. The factor of 2 comes from the fact that at any instant two FETs are conducting winding current (one high-side and one low-side).

The maximum amount of power that can be dissipated in the device is dependent on ambient temperature and heatsinking.

Note that  $R_{DS(ON)}$  increases with temperature, so as the device heats, the power dissipation increases. This must be taken into consideration when sizing the heatsink.

### Heatsinking

The PowerPAD™ package uses an exposed pad to remove heat from the device. For proper operation, this pad must be thermally connected to copper on the PCB to dissipate heat. On a multi-layer PCB with a ground plane, this can be accomplished by adding a number of vias to connect the thermal pad to the ground plane. On PCBs without internal planes, copper area can be added on either side of the PCB to dissipate heat. If the copper area is on the opposite side of the PCB from the device, thermal vias are used to transfer the heat between top and bottom layers.

For details about how to design the PCB, refer to TI application report [SLMA002](#), "PowerPAD™ Thermally Enhanced Package" and TI application brief [SLMA004](#), "PowerPAD™ Made Easy", available at [www.ti.com](http://www.ti.com).

In general, the more copper area that can be provided, the more power can be dissipated.

**PACKAGING INFORMATION**

| Orderable Device | Status <sup>(1)</sup> | Package Type | Package Drawing | Pins | Package Qty | Eco Plan <sup>(2)</sup>    | Lead/<br>Ball Finish | MSL Peak Temp <sup>(3)</sup> | Samples<br>(Requires Login) |
|------------------|-----------------------|--------------|-----------------|------|-------------|----------------------------|----------------------|------------------------------|-----------------------------|
| DRV8840PWP       | ACTIVE                | HTSSOP       | PWP             | 28   | 50          | Green (RoHS<br>& no Sb/Br) | CU NIPDAU            | Level-3-260C-168 HR          |                             |
| DRV8840PWPR      | ACTIVE                | HTSSOP       | PWP             | 28   | 2000        | Green (RoHS<br>& no Sb/Br) | CU NIPDAU            | Level-3-260C-168 HR          |                             |

<sup>(1)</sup> The marketing status values are defined as follows:

**ACTIVE:** Product device recommended for new designs.

**LIFEBUY:** TI has announced that the device will be discontinued, and a lifetime-buy period is in effect.

**NRND:** Not recommended for new designs. Device is in production to support existing customers, but TI does not recommend using this part in a new design.

**PREVIEW:** Device has been announced but is not in production. Samples may or may not be available.

**OBSOLETE:** TI has discontinued the production of the device.

<sup>(2)</sup> Eco Plan - The planned eco-friendly classification: Pb-Free (RoHS), Pb-Free (RoHS Exempt), or Green (RoHS & no Sb/Br) - please check <http://www.ti.com/productcontent> for the latest availability information and additional product content details.

**TBD:** The Pb-Free/Green conversion plan has not been defined.

**Pb-Free (RoHS):** TI's terms "Lead-Free" or "Pb-Free" mean semiconductor products that are compatible with the current RoHS requirements for all 6 substances, including the requirement that lead not exceed 0.1% by weight in homogeneous materials. Where designed to be soldered at high temperatures, TI Pb-Free products are suitable for use in specified lead-free processes.

**Pb-Free (RoHS Exempt):** This component has a RoHS exemption for either 1) lead-based flip-chip solder bumps used between the die and package, or 2) lead-based die adhesive used between the die and leadframe. The component is otherwise considered Pb-Free (RoHS compatible) as defined above.

**Green (RoHS & no Sb/Br):** TI defines "Green" to mean Pb-Free (RoHS compatible), and free of Bromine (Br) and Antimony (Sb) based flame retardants (Br or Sb do not exceed 0.1% by weight in homogeneous material)

<sup>(3)</sup> MSL, Peak Temp. -- The Moisture Sensitivity Level rating according to the JEDEC industry standard classifications, and peak solder temperature.

**Important Information and Disclaimer:** The information provided on this page represents TI's knowledge and belief as of the date that it is provided. TI bases its knowledge and belief on information provided by third parties, and makes no representation or warranty as to the accuracy of such information. Efforts are underway to better integrate information from third parties. TI has taken and continues to take reasonable steps to provide representative and accurate information but may not have conducted destructive testing or chemical analysis on incoming materials and chemicals. TI and TI suppliers consider certain information to be proprietary, and thus CAS numbers and other limited information may not be available for release.

In no event shall TI's liability arising out of such information exceed the total purchase price of the TI part(s) at issue in this document sold by TI to Customer on an annual basis.

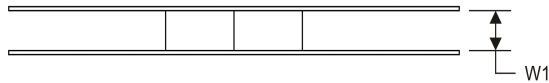
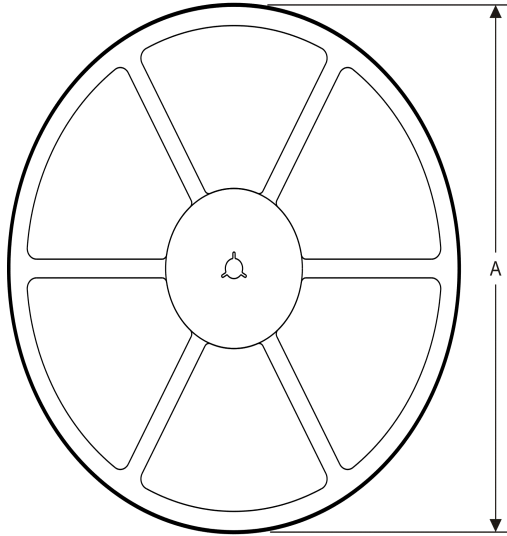
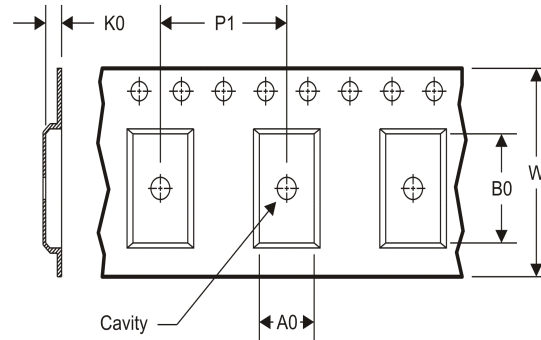
**TAPE AND REEL INFORMATION**
**REEL DIMENSIONS**

**TAPE DIMENSIONS**

|    |   |
|----|---|
| A0 | Dimension designed to accommodate the component width     |
| B0 | Dimension designed to accommodate the component length    |
| K0 | Dimension designed to accommodate the component thickness |
| W  | Overall width of the carrier tape                         |
| P1 | Pitch between successive cavity centers                   |

**TAPE AND REEL INFORMATION**

\*All dimensions are nominal

| Device      | Package Type | Package Drawing | Pins | SPQ  | Reel Diameter (mm) | Reel Width W1 (mm) | A0 (mm) | B0 (mm) | K0 (mm) | P1 (mm) | W (mm) | Pin1 Quadrant |
|-------------|--------------|-----------------|------|------|--------------------|--------------------|---------|---------|---------|---------|--------|---------------|
| DRV8840PWPR | HTSSOP       | PWP             | 28   | 2000 | 330.0              | 16.4               | 6.9     | 10.2    | 1.8     | 12.0    | 16.0   | Q1            |

TAPE AND REEL BOX DIMENSIONS



\*All dimensions are nominal

| Device      | Package Type | Package Drawing | Pins | SPQ  | Length (mm) | Width (mm) | Height (mm) |
|-------------|--------------|-----------------|------|------|-------------|------------|-------------|
| DRV8840PWPR | HTSSOP       | PWP             | 28   | 2000 | 367.0       | 367.0      | 38.0        |

# MECHANICAL DATA

PWP (R-PDSO-G28)

PowerPAD™ PLASTIC SMALL OUTLINE

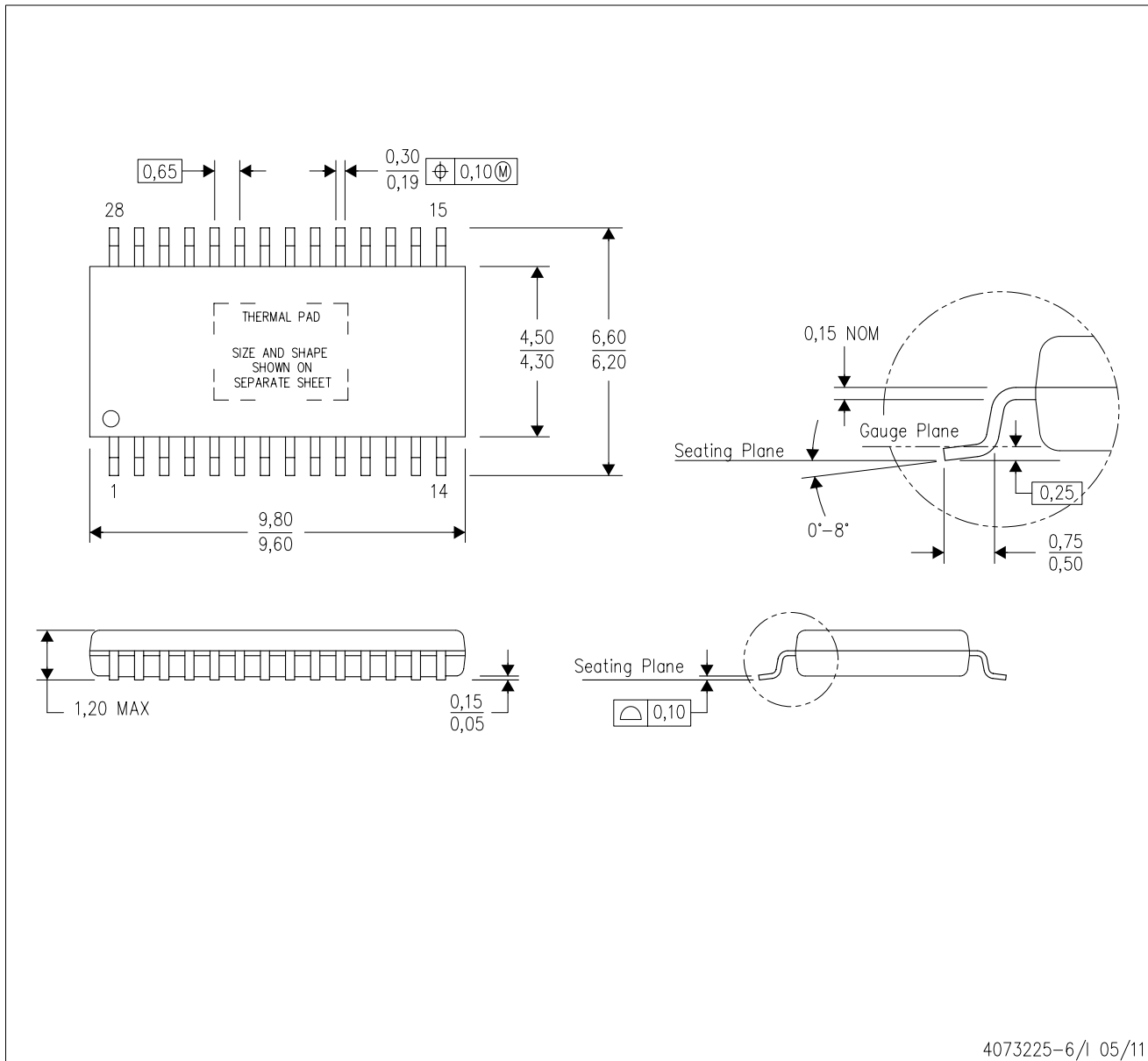

- NOTES:
- All linear dimensions are in millimeters.
  - This drawing is subject to change without notice.
  - Body dimensions do not include mold flash or protrusions. Mold flash and protrusion shall not exceed 0.15 per side.
  - This package is designed to be soldered to a thermal pad on the board. Refer to Technical Brief, PowerPad Thermally Enhanced Package, Texas Instruments Literature No. SLMA002 for information regarding recommended board layout. This document is available at [www.ti.com](http://www.ti.com) <<http://www.ti.com>>.
  - See the additional figure in the Product Data Sheet for details regarding the exposed thermal pad features and dimensions.
  - Falls within JEDEC MO-153

PowerPAD is a trademark of Texas Instruments.

# THERMAL PAD MECHANICAL DATA

## PWP (R-PDSO-G28) PowerPAD™ SMALL PLASTIC OUTLINE

### THERMAL INFORMATION

This PowerPAD™ package incorporates an exposed thermal pad that is designed to be attached to a printed circuit board (PCB). The thermal pad must be soldered directly to the PCB. After soldering, the PCB can be used as a heatsink. In addition, through the use of thermal vias, the thermal pad can be attached directly to the appropriate copper plane shown in the electrical schematic for the device, or alternatively, can be attached to a special heatsink structure designed into the PCB. This design optimizes the heat transfer from the integrated circuit (IC).

For additional information on the PowerPAD package and how to take advantage of its heat dissipating abilities, refer to Technical Brief, PowerPAD Thermally Enhanced Package, Texas Instruments Literature No. SLMA002 and Application Brief, PowerPAD Made Easy, Texas Instruments Literature No. SLMA004. Both documents are available at [www.ti.com](http://www.ti.com).

The exposed thermal pad dimensions for this package are shown in the following illustration.

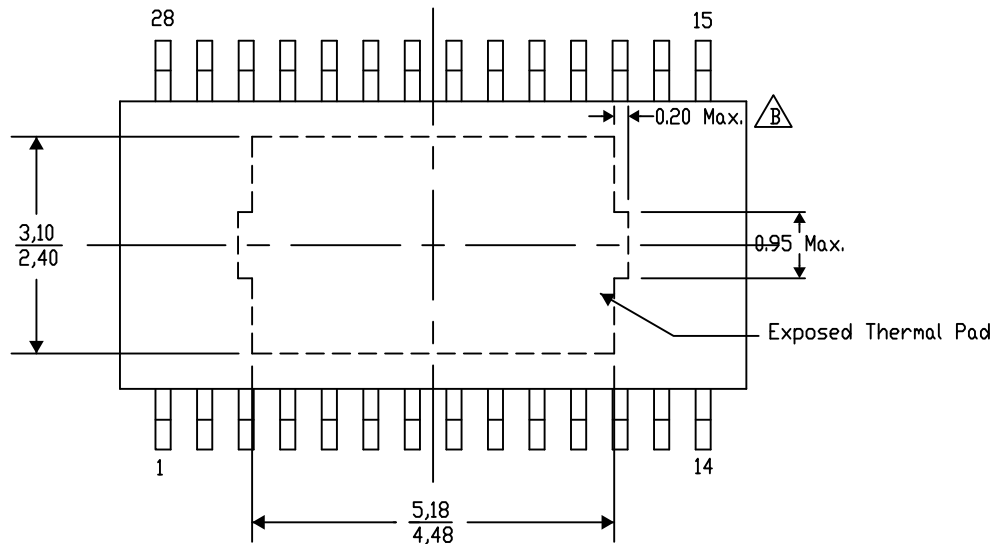

Exposed Thermal Pad Dimensions

4206332-38/AC 07/12

NOTE: A. All linear dimensions are in millimeters  
B. Exposed tie strap features may not be present.

PowerPAD is a trademark of Texas Instruments



PWP (R-PDSO-G28)

PowerPAD™ PLASTIC SMALL OUTLINE

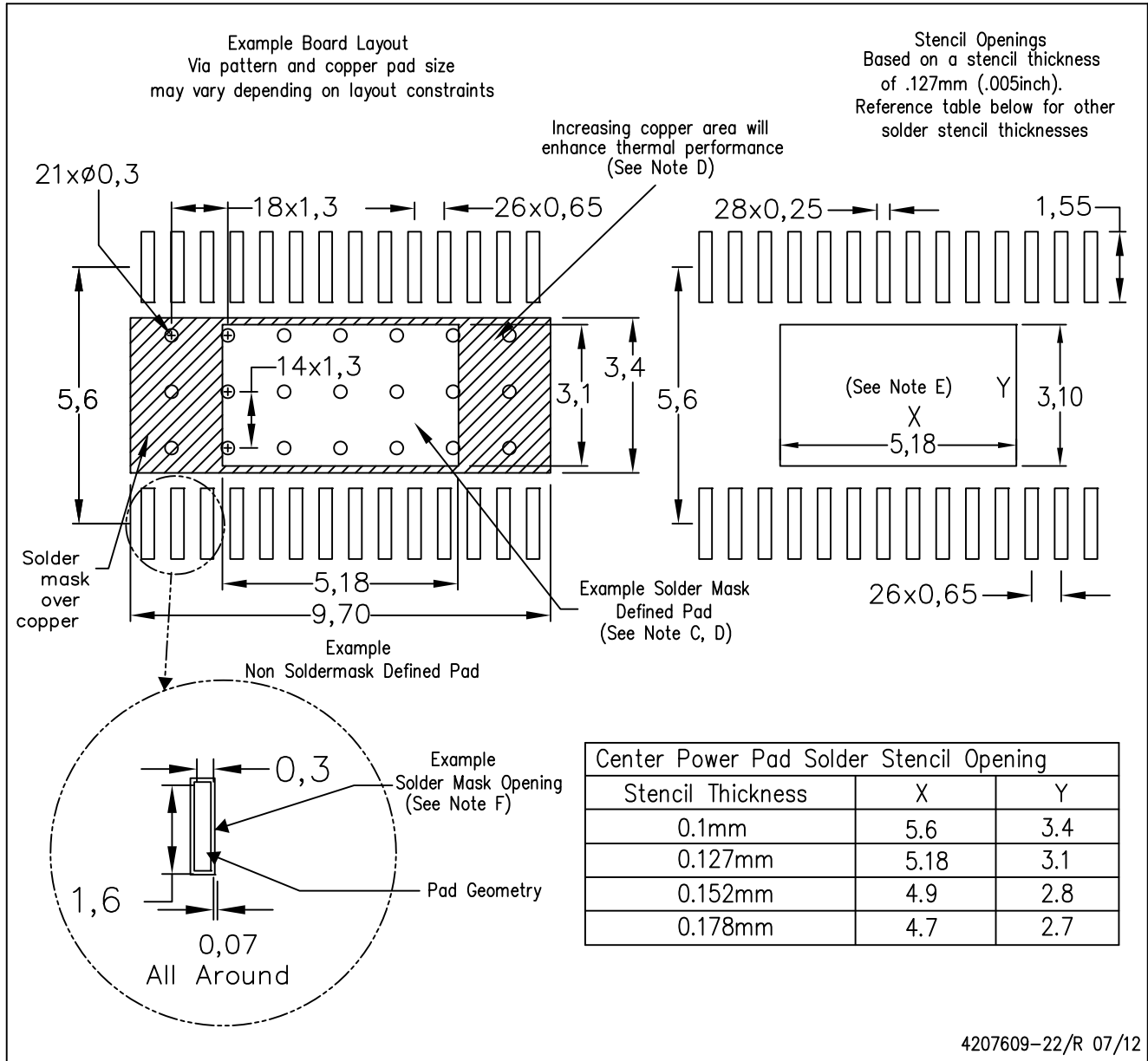

- NOTES:
- All linear dimensions are in millimeters.
  - This drawing is subject to change without notice.
  - Customers should place a note on the circuit board fabrication drawing not to alter the center solder mask defined pad.
  - This package is designed to be soldered to a thermal pad on the board. Refer to Technical Brief, PowerPad Thermally Enhanced Package, Texas Instruments Literature No. SLMA002, SLMA004, and also the Product Data Sheets.
  - For specific thermal information, via requirements, and recommended board layout. These documents are available at [www.ti.com](http://www.ti.com) <<http://www.ti.com>>. Publication IPC-7351 is recommended for alternate designs. Laser cutting apertures with trapezoidal walls and also rounding corners will offer better paste release. Customers should contact their board assembly site for stencil design recommendations. Example stencil design based on a 50% volumetric metal load solder paste. Refer to IPC-7525 for other stencil
  - Customers should contact their board fabrication site for solder mask tolerances between and around signal pads.

## IMPORTANT NOTICE

Texas Instruments Incorporated and its subsidiaries (TI) reserve the right to make corrections, enhancements, improvements and other changes to its semiconductor products and services per JESD46C and to discontinue any product or service per JESD48B. Buyers should obtain the latest relevant information before placing orders and should verify that such information is current and complete. All semiconductor products (also referred to herein as "components") are sold subject to TI's terms and conditions of sale supplied at the time of order acknowledgment.

TI warrants performance of its components to the specifications applicable at the time of sale, in accordance with the warranty in TI's terms and conditions of sale of semiconductor products. Testing and other quality control techniques are used to the extent TI deems necessary to support this warranty. Except where mandated by applicable law, testing of all parameters of each component is not necessarily performed.

TI assumes no liability for applications assistance or the design of Buyers' products. Buyers are responsible for their products and applications using TI components. To minimize the risks associated with Buyers' products and applications, Buyers should provide adequate design and operating safeguards.

TI does not warrant or represent that any license, either express or implied, is granted under any patent right, copyright, mask work right, or other intellectual property right relating to any combination, machine, or process in which TI components or services are used. Information published by TI regarding third-party products or services does not constitute a license to use such products or services or a warranty or endorsement thereof. Use of such information may require a license from a third party under the patents or other intellectual property of the third party, or a license from TI under the patents or other intellectual property of TI.

Reproduction of significant portions of TI information in TI data books or data sheets is permissible only if reproduction is without alteration and is accompanied by all associated warranties, conditions, limitations, and notices. TI is not responsible or liable for such altered documentation. Information of third parties may be subject to additional restrictions.

Resale of TI components or services with statements different from or beyond the parameters stated by TI for that component or service voids all express and any implied warranties for the associated TI component or service and is an unfair and deceptive business practice. TI is not responsible or liable for any such statements.

Buyer acknowledges and agrees that it is solely responsible for compliance with all legal, regulatory and safety-related requirements concerning its products, and any use of TI components in its applications, notwithstanding any applications-related information or support that may be provided by TI. Buyer represents and agrees that it has all the necessary expertise to create and implement safeguards which anticipate dangerous consequences of failures, monitor failures and their consequences, lessen the likelihood of failures that might cause harm and take appropriate remedial actions. Buyer will fully indemnify TI and its representatives against any damages arising out of the use of any TI components in safety-critical applications.

In some cases, TI components may be promoted specifically to facilitate safety-related applications. With such components, TI's goal is to help enable customers to design and create their own end-product solutions that meet applicable functional safety standards and requirements. Nonetheless, such components are subject to these terms.

No TI components are authorized for use in FDA Class III (or similar life-critical medical equipment) unless authorized officers of the parties have executed a special agreement specifically governing such use.

Only those TI components which TI has specifically designated as military grade or "enhanced plastic" are designed and intended for use in military/aerospace applications or environments. Buyer acknowledges and agrees that any military or aerospace use of TI components which have **not** been so designated is solely at the Buyer's risk, and that Buyer is solely responsible for compliance with all legal and regulatory requirements in connection with such use.

TI has specifically designated certain components which meet ISO/TS16949 requirements, mainly for automotive use. Components which have not been so designated are neither designed nor intended for automotive use; and TI will not be responsible for any failure of such components to meet such requirements.

### Products

|                        |  |
|------------------------|--|
| Audio                  | <a href="http://www.ti.com/audio">www.ti.com/audio</a>                               |
| Amplifiers             | <a href="http://amplifier.ti.com">amplifier.ti.com</a>                               |
| Data Converters        | <a href="http://dataconverter.ti.com">dataconverter.ti.com</a>                       |
| DLP® Products          | <a href="http://www.dlp.com">www.dlp.com</a>   |
| DSP                    | <a href="http://dsp.ti.com">dsp.ti.com</a>   |
| Clocks and Timers      | <a href="http://www.ti.com/clocks">www.ti.com/clocks</a>                             |
| Interface              | <a href="http://interface.ti.com">interface.ti.com</a>                               |
| Logic                  | <a href="http://logic.ti.com">logic.ti.com</a>                                       |
| Power Mgmt             | <a href="http://power.ti.com">power.ti.com</a>                                       |
| Microcontrollers       | <a href="http://microcontroller.ti.com">microcontroller.ti.com</a>                   |
| RFID                   | <a href="http://www.ti-rfid.com">www.ti-rfid.com</a>                                 |
| OMAP Mobile Processors | <a href="http://www.ti.com/omap">www.ti.com/omap</a>                                 |
| Wireless Connectivity  | <a href="http://www.ti.com/wirelessconnectivity">www.ti.com/wirelessconnectivity</a> |

### Applications

|                               |  |
|-------------------------------|--|
| Automotive and Transportation | <a href="http://www.ti.com/automotive">www.ti.com/automotive</a>                         |
| Communications and Telecom    | <a href="http://www.ti.com/communications">www.ti.com/communications</a>                 |
| Computers and Peripherals     | <a href="http://www.ti.com/computers">www.ti.com/computers</a>                           |
| Consumer Electronics          | <a href="http://www.ti.com/consumer-apps">www.ti.com/consumer-apps</a>                   |
| Energy and Lighting           | <a href="http://www.ti.com/energy">www.ti.com/energy</a>                                 |
| Industrial                    | <a href="http://www.ti.com/industrial">www.ti.com/industrial</a>                         |
| Medical                       | <a href="http://www.ti.com/medical">www.ti.com/medical</a>                               |
| Security                      | <a href="http://www.ti.com/security">www.ti.com/security</a>                             |
| Space, Avionics and Defense   | <a href="http://www.ti.com/space-avionics-defense">www.ti.com/space-avionics-defense</a> |
| Video and Imaging             | <a href="http://www.ti.com/video">www.ti.com/video</a>                                   |

**TI E2E Community** [e2e.ti.com](http://e2e.ti.com)