

DP8391A/NS32491A SNI Serial Network Interface

General Description

The DP8391A Serial Network Interface (SNI) provides the Manchester data encoding and decoding functions for IEEE 802.3 Ethernet/Cheapernet type local area networks. The SNI interfaces the DP8390 Network Interface Controller (NIC) to the Ethernet transceiver cable. When transmitting, the SNI converts non-return-to-zero (NRZ) data from the controller and clock pulses into Manchester encoding and sends the converted data differentially to the transceiver. The opposite process occurs on the receive path, where a digital phase-locked loop decodes 10 Mbit/s signals with as much as ± 18 ns of jitter.

The DP8391A SNI is a functionally complete Manchester encoder/decoder including ECL like balanced driver and receivers, on board crystal oscillator, collision signal translator, and a diagnostic loopback circuit.

The SNI is part of a three chip set that implements the complete IEEE compatible network node electronics as shown below. The other two chips are the DP8392 Coax Transceiver Interface (CTI) and the DP8390 Network Interface Controller (NIC).

Incorporated into the CTI are the transceiver, collision and jabber functions. The Media Access Protocol and the buffer management tasks are performed by the NIC. There is an isolation requirement on signal and power lines between the CTI and the SNI. This is usually accomplished by using a set of miniature pulse transformers that come in a 16-pin plastic DIP for signal lines. Power isolation, however, is done by using a DC to DC converter.

Features

- Compatible with Ethernet II, IEEE 802.3; 10Base5, 10Base2, and 10Base-T

- 10 Mb/s Manchester encoding/decoding with receive clock recovery
- Patented digital phase locked loop (DPLL) decoder requires no precision external components
- Decodes Manchester data with up to ± 18 ns of jitter
- Loopback capability for diagnostics
- Externally selectable half or full step modes of operation at transmit output
- Squelch circuits at the receive and collision inputs reject noise
- High voltage protection at transceiver interface (16V)
- TTL/MOS compatible controller interface
- Connects directly to the transceiver (AUI) cable

Table of Contents

- 1.0 System Diagram
- 2.0 Block Diagram
- 3.0 Functional Description
 - 3.1 Oscillator
 - 3.2 Encoder
 - 3.3 Decoder
 - 3.4 Collision Translator
 - 3.5 Loopback
- 4.0 Connection Diagrams
- 5.0 Pin Descriptions
- 6.0 Absolute Maximum Ratings
- 7.0 Electrical Characteristics
- 8.0 Switching Characteristics
- 9.0 Timing and Load Diagrams
- 10.0 Physical Dimensions

1.0 System Diagram

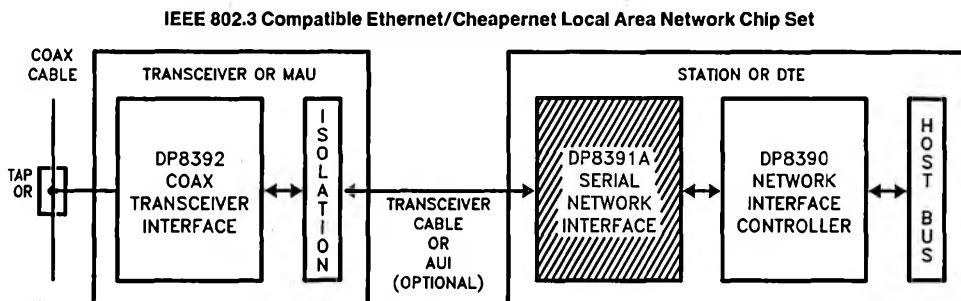

TL/F/9357-1

2.0 Block Diagram

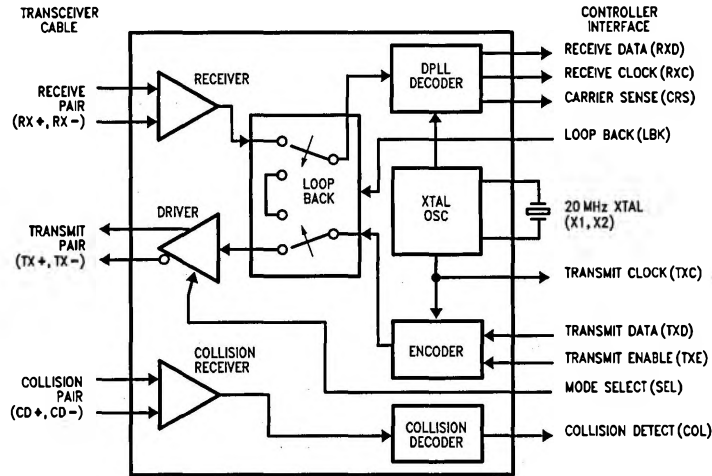

FIGURE 1

TL/F/9357-2

3.0 Functional Description

The SNI consists of five main logical blocks:

- the oscillator—generates the 10 MHz transmit clock signal for system timing.
- the Manchester encoder and differential output driver—accepts NRZ data from the controller, performs Manchester encoding, and transmits it differentially to the transceiver.
- the Manchester decoder—receives Manchester data from the transceiver, converts it to NRZ data and clock pulses, and sends them to the controller.
- the collision translator—indicates to the controller the presence of a valid 10 MHz signal at its input.
- the loopback circuitry—when asserted, switches encoded data instead of receive input signals to the digital phase-locked loop.

3.1 OSCILLATOR

The oscillator is controlled by a 20 MHz parallel resonant crystal connected between X1 and X2 or by an external clock on X1. The 20 MHz output of the oscillator is divided by 2 to generate the 10 MHz transmit clock for the controller. The oscillator also provides internal clock signals to the encoding and decoding circuits.

Crystal Specification

Resonant frequency	20 MHz
Tolerance	± 0.001% at 25°C
Stability	± 0.005% 0–70°C
Type	AT-Cut
Circuit	Parallel Resonance

The 20 MHz crystal connection to the SNI requires special care. The IEEE 802.3 standard requires a 0.01% absolute accuracy on the transmitted signal frequency. Stray capacitance can shift the crystal's frequency out of range, causing

the transmitted frequency to exceed its 0.01% tolerance. The frequency marked on the crystal is usually measured with a fixed shunt capacitance (C_L) that is specified in the crystal's data sheet. This capacitance for 20 MHz crystals is typically 20 pF. The capacitance between the X1 and X2 pins of the SNI, of the PC board traces and the plated through holes plus any stray capacitance such as the socket capacitance, if one is used, should be estimated or measured. Once the total sum of these capacitances is determined, the value of additional external shunt capacitance required can be calculated. This capacitor can be a fixed 5% tolerance component. The frequency accuracy should be measured during the design phase at the transmit clock pin (TxC) for a given pc layout. Figure 2 shows the crystal connection.

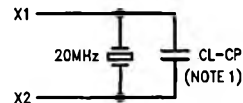

TL/F/9357-3

CL = Load capacitance specified by the crystal's manufacturer

CP = Total parasitic capacitance including:

- SNI input capacitance between X1 and X2 (typically 5 pF)
- PC board traces, plated through holes, socket capacitances

Note 1: When using a Viking (San Jose) VXB49N5 crystal, the external capacitor is not required, as the C_L of the crystal matches the input capacitance of the DP8391A.

FIGURE 2. Crystal Connection

3.2 MANCHESTER ENCODER AND DIFFERENTIAL DRIVER

The encoder combines clock and data information for the transceiver. Data encoding and transmission begins with the transmit enable input (TXE) going high. As long as TXE is

3.0 Functional Description (Continued)

mains high, transmit data (TXD) is encoded out to the transmit-driver pair (TX±). The transmit enable and transmit data inputs must meet the setup and hold time requirements with respect to the rising edge of transmit clock. Transmission ends with the transmit enable input going low. The last transition is always positive at the transmit output pair. It will occur at the center of the bit cell if the last bit is one, or at the boundary of the bit cell if the last bit is zero.

The differential line driver provides ECL like signals to the transceiver with typically 5 ns rise and fall times. It can drive up to 50 meters of twisted pair AUI Ethernet transceiver cable. These outputs are source followers which need external 270Ω pulldown resistors to ground. Two different modes, full-step or half-step, can be selected with SEL input. With SEL low, transmit + is positive with respect to transmit - in the idle state. With SEL high, transmit + and transmit - are equal in the idle state, providing zero differential voltage to operate with transformer coupled loads. Figures 4, 5 and 6 illustrate the transmit timing.

3.3 MANCHESTER DECODER

The decoder consists of a differential input circuitry and a digital phase-locked loop to separate Manchester encoded data stream into clock signals and NRZ data. The differential input should be externally terminated if the standard 78Ω transceiver drop cable is used. Two 39Ω resistors connected in series and one optional common mode bypass capacitor would accomplish this. A squelch circuit at the input rejects signals with pulse widths less than 5 ns (negative going), or with levels less than -175 mV. Signals more negative than -300 mV and with a duration greater than 30 ns are always decoded. This prevents noise at the input from falsely triggering the decoder in the absence of a valid signal. Once the input exceeds the squelch requirements,

carrier sense (CRS) is asserted. Receive data (RXD) and receive clock (RXC) become available typically within 6 bit times. At this point the digital phase-locked loop has locked to the incoming signal. The DP8391A decodes a data frame with up to ±18 ns of jitter correctly.

The decoder detects the end of a frame when the normal mid-bit transition on the differential input ceases. Within one and a half bit times after the last bit, carrier sense is de-asserted. Receive clock stays active for five more bit times before it goes low and remains low until the next frame. Figures 7, 8 and 9 illustrate the receive timing.

3.4 COLLISION TRANSLATOR

The Ethernet transceiver detects collisions on the coax cable and generates a 10 MHz signal on the transceiver cable. The SNI's collision translator asserts the collision detect output (COL) to the DP8390 controller when a 10 MHz signal is present at the collision inputs. The controller uses this signal to back off transmission and recycle itself. The collision detect output is de-asserted within 350 ns after the 10 MHz input signal disappears.

The collision differential inputs (+ and -) should be terminated in exactly the same way as the receive inputs. The collision input also has a squelch circuit that rejects signals with pulse widths less than 5 ns (negative going), or with levels less than -175 mV. Figure 10 illustrates the collision timing.

3.5 LOOPBACK FUNCTIONS

Logic high at loopback input (LBK) causes the SNI to route serial data from the transmit data input, through its encoder, returning it through the phase-locked-loop decoder to receive data output. In loopback mode, the transmit driver is in idle state and the receive and collision input circuitries are disabled.

4.0 Connection Diagram

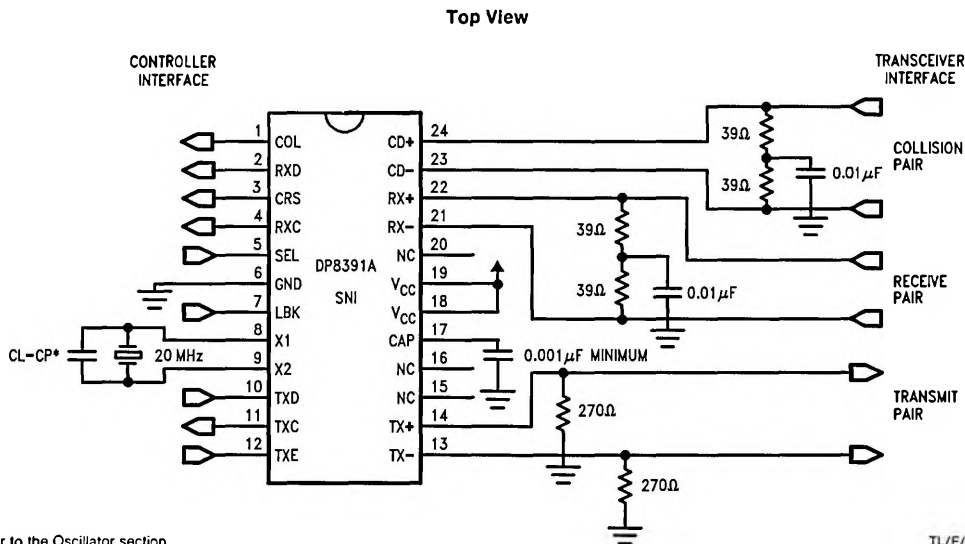

*Refer to the Oscillator section

TL/F/9357-4

FIGURE 3a

Order Number DP8391AN
See NS Package Number N24C

PCC Connection Diagram

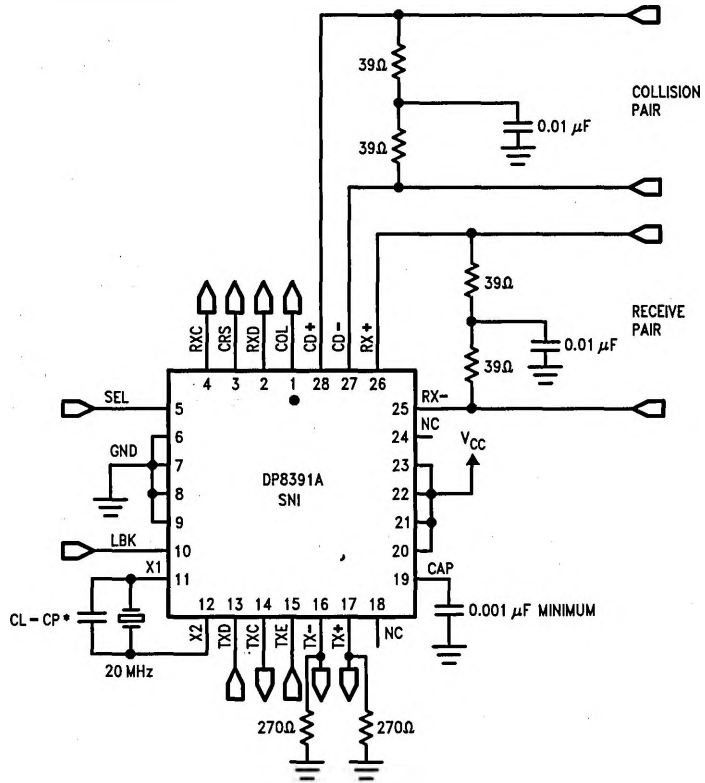

*Refer to the Oscillator section

TL/F/9357-5

FIGURE 3b
Order Number DP8391AV
NS Package Number V28A

5.0 Pin Descriptions

Pin No.		Name	I/O	Description
(DIP)	(PCC)			
1	1	COL	O	Collision Detect Output. A TTL/MOS level active high output. A 10 MHz (+ 25% - 15%) signal at the collision input will produce a logic high at COL output. When no signal is present at the collision input, COL output will go low.
2	2	RXD	O	Receive Data Output. A TTL/MOS level signal. This is the NRZ data output from the digital phase-locked loop. This signal should be sampled by the controller at the rising edge of receive clock.
3	3	CRS	O	Carrier Sense. A TTL/MOS level active high signal. It is asserted when valid data from the transceiver is present at the receive input. It is de-asserted one and a half bit times after the last bit at receive input.
4	4	RXC	O	Receive Clock. A TTL/MOS level recovered clock. When the phase-locked loop locks to a valid incoming signal a 10 MHz clock signal is activated on this output. This output remains low during idle (5 bit times after activity ceases at receive input).
5	5	SEL	I	Mode Select. A TTL level input. When high, transmit + and transmit - outputs are at the same voltage in idle state providing a "zero" differential. When low, transmit + is positive with respect to transmit - in idle state.
6	6-9	GND		Negative Supply Pins.
7	10	LBK	I	Loopback. A TTL level active high on this input enables the loopback mode.
8	11	X1	I	Crystal or External Frequency Source Input (TTL).
9	12	X2	O	Crystal Feedback Output. This output is used in the crystal connection only. It must be left open when driving X1 with an external frequency source.
10	13	TXD	I	Transmit Data. A TTL level input. This signal is sampled by the SNI at the rising edge of transmit clock when transmit enable input is high. The SNI combines transmit data and transmit clock signals into a Manchester encoded bit stream and sends it differentially to the transceiver.
11	14	TXC	O	Transmit Clock. A TTL/MOS level 10 MHz clock signal derived from the 20 MHz oscillator. This clock signal is always active.
12	15	TXE	I	Transmit Enable. A TTL level active high data encoder enable input. This signal is also sampled by the SNI at the rising edge of transmit clock.
13 14	16 17	TX- TX+	O	Transmit Output. Differential line driver which sends the encoded data to the transceiver. These outputs are source followers and require 270Ω pulldown resistors to GND.
15 16	18	NC		No Connection.
17	19	CAP	O	Bypass Capacitor. A ceramic capacitor (greater than 0.001 μF) must be connected from this pin to GND.
18 19	20-23	VCC		Positive Supply Pins. A 0.1 μF ceramic decoupling capacitor must be connected across VCC and GND as close to the device as possible.
20	24	NC		No Connection.
21 22	25 26	RX- RX+	I	Receive Input. Differential receive input pair from the transceiver.
23 24	27 28	CD- CD+	I	Collision Input. Differential collision input pair from the transceiver.

6.0 Absolute Maximum Ratings

Supply Voltage (V_{CC})	7V
Input Voltage (TTL)	0 to 5.5V
Input Voltage (differential)	-5.5 to +16V
Output Voltage (differential)	0 to 16V
Output Current (differential)	-40 mA
Storage Temperature	-65° to 150°C
Lead Temperature (soldering, 10 sec)	300°C
Package Power Rating for DIP at 25°C (PC Board Mounted)	2.95W*
Derate Linearly at the rate of 23.8 mW/°C	
Package Power Rating for PCC at 25°C	1.92W*
Derate Linearly at the rate of 15.4 mW/°C	
*For actual power dissipation of the device please refer to Section 7.0.	
ESD rating	2000V

Recommended Operating Conditions

Supply Voltage (V_{CC})	5V ± 5%
Ambient Temperature (DIP)	0° to 70°C
(PCC)	0° to 55°C

Note: Absolute maximum ratings are those values beyond which the safety of the device cannot be guaranteed. They are not meant to imply that the device should be operated at these limits.

7.0 Electrical Characteristics

$V_{CC} = 5V \pm 5\%$, $T_A = 0^\circ C$ to $70^\circ C$ for DIP and $0^\circ C$ to $55^\circ C$ for PCC (Notes 1 & 2)

Symbol	Parameter	Test Conditions	Min	Max	Units
V_{IH}	Input High Voltage (TTL)		2.0		V
V_{IHx1a}	Input High Voltage (X1)	No Series Resistor	2.0	$V_{CC} - 1.5$	V
V_{IHx1b}	Input High Voltage (X1)	1k Series Resistor	2.0	V_{CC}	V
V_{IL}	Input Low Voltage (TTL and X1)			0.8	V
I_{IH}	Input High Current (TTL)	$V_{IN} = V_{CC}$		50	μA
	Input High Current (RX ± CD ±)	$V_{IN} = V_{CC}$		500	μA
I_{IL}	Input Low Current (TTL)	$V_{IN} = 0.5V$		-300	μA
	Input Low Current (RX ± CD ±)	$V_{IN} = 0.5V$		-700	μA
V_{CL}	Input Clamp Voltage (TTL)	$I_{IN} = -12 mA$		-1.2	V
V_{OH}	Output High Voltage (TTL/MOS)	$I_{OH} = -100 \mu A$	3.5		V
V_{OL}	Output Low Voltage (TTL/MOS)	$I_{OL} = 8 mA$		0.5	V
I_{OS}	Output Short Circuit Current (TTL/MOS)		-40	-200	mA
V_{OD}	Differential Output Voltage (TX ±)	78 Ω termination, and 270 Ω from each to GND	± 550	± 1200	mV
V_{OB}	Diff. Output Voltage Imbalance (TX ±)	same as above		± 40	mV
V_{DS}	Diff. Squelch Threshold (RX ± CD ±)		-175	-300	mV
V_{CM}	Diff. Input Common Mode Voltage (RX ± CD ±)		-5.25	5.25	V
I_{CC}	Power Supply Current	10Mbit/s		270	mA

8.0 Switching Characteristics $V_{CC} = 5V \pm 5\%$, $T_A = 0^\circ C$ to $70^\circ C$ for DIP and $0^\circ C$ to $55^\circ C$ for PCC (Note 2)

Symbol	Parameter	Figure	Min	Typ	Max	Units
OSCILLATOR SPECIFICATION						
t_{XTH}	X1 to Transmit Clock High	12	8		20	ns
t_{XTL}	X1 to Transmit Clock Low	12	8		20	ns
TRANSMIT SPECIFICATION						
t_{TCd}	Transmit Clock Duty Cycle at 50% (10 MHz)	12	42	50	58	%
t_{TCr}	Transmit Clock Rise Time (20% to 80%)	12			8	ns
t_{TCf}	Transmit Clock Fall Time (80% to 20%)	12			8	ns
t_{TDs}	Transmit Data Setup Time to Transmit Clock Rising Edge	4 & 12	20			ns
t_{TDh}	Transmit Data Hold Time from Transmit Clock Rising Edge	4 & 12	0			ns
t_{TEs}	Transmit Enable Setup Time to Trans. Clock Rising Edge	4 & 12	20			ns
t_{TEh}	Transmit Enable Hold Time from Trans. Clock Rising Edge	5 & 12	0			ns

Note 1: All currents into device pins are positive, all currents out of device pins are negative. All voltages are referenced to ground unless otherwise specified.

Note 2: All typicals are given for $V_{CC} = 5V$ and $T_A = 25^\circ C$.

8.0 Switching Characteristics

$V_{CC} = 5V \pm 5\%$, $T_A = 0^\circ\text{C}$ to 70°C for DIP and 0°C to 55°C for PCC (Note 2) (Continued)

Symbol	Parameter	Figure	Min	Typ	Max	Units
TRANSMIT SPECIFICATION (Continued)						
t_{TOd}	Transmit Output Delay from Transmit Clock Rising Edge	4 & 12			50	ns
t_{TOr}	Transmit Output Rise Time (20% to 80%)	12			7	ns
t_{TOf}	Transmit Output Fall Time (80% to 20%)	12			7	ns
t_{TOi}	Transmit Output Jitter	12		± 0.25		ns
t_{TOh}	Transmit Output High Before Idle in Half Step Mode	5 & 12	200			ns
t_{TOi}	Transmit Output Idle Time in Half Step Mode	5 & 12			800	ns
RECEIVE SPECIFICATION						
t_{RCd}	Receive Clock Duty Cycle at 50% (10 MHz)	12	40	50	60	%
t_{RCr}	Receive Clock Rise Time (20% to 80%)	12			8	ns
t_{RCf}	Receive Clock Fall Time (80% to 20%)	12			8	ns
t_{RDr}	Receive Data Rise Time (20% to 80%)	12			8	ns
t_{RDF}	Receive Data Fall Time (80% to 20%)	12			8	ns
t_{RDs}	Receive Data Stable from Receive Clock Rising Edge	7 & 12	± 40			ns
t_{CSon}	Carrier Sense Turn On Delay	7 & 12			50	ns
t_{CSoff}	Carrier Sense Turn Off Delay	8, 9 & 12			160	ns
t_{DAT}	Decoder Acquisition Time	7		0.6	1.80	μs
t_{Drei}	Differential Inputs Rejection Pulse Width (Squelch)	7	5		30	ns
t_{Rd}	Receive Throughput Delay	8 & 12			150	ns
COLLISION SPECIFICATION						
t_{COLon}	Collision Turn On Delay	10 & 12			50	ns
t_{COLoff}	Collision Turn Off Delay	10 & 12			350	ns
LOOPBACK SPECIFICATION						
t_{LBs}	Loopback Setup Time	11	20			ns
t_{LBh}	Loopback Hold Time	11	0			ns

Note 2: All typicals are given for $V_{CC} = 5V$ and $T_A = 25^\circ\text{C}$.

9.0 Timing and Load Diagrams

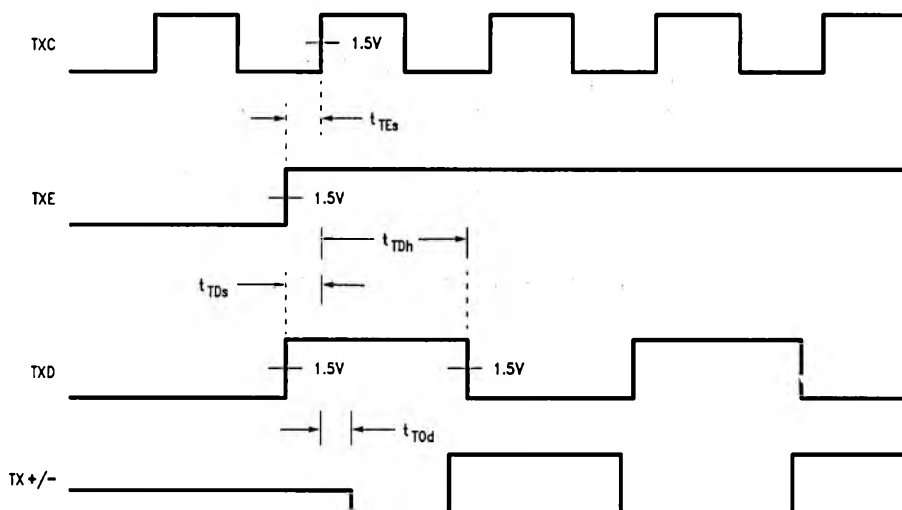

FIGURE 4. Transmit Timing - Start of Transmission

TL/F/9357-6

9.0 Timing and Load Diagrams (Continued)

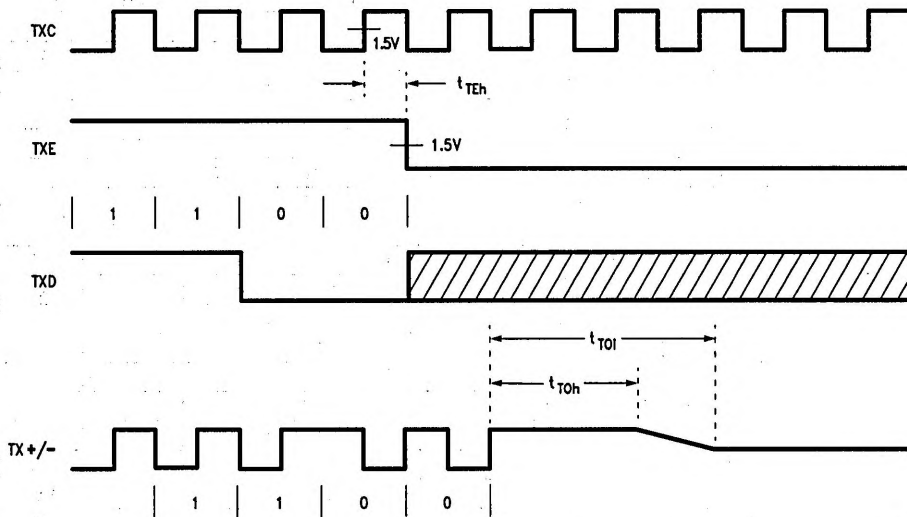

FIGURE 5. Transmit Timing - End of Transmission (last bit = 0)

TL/F/9357-7

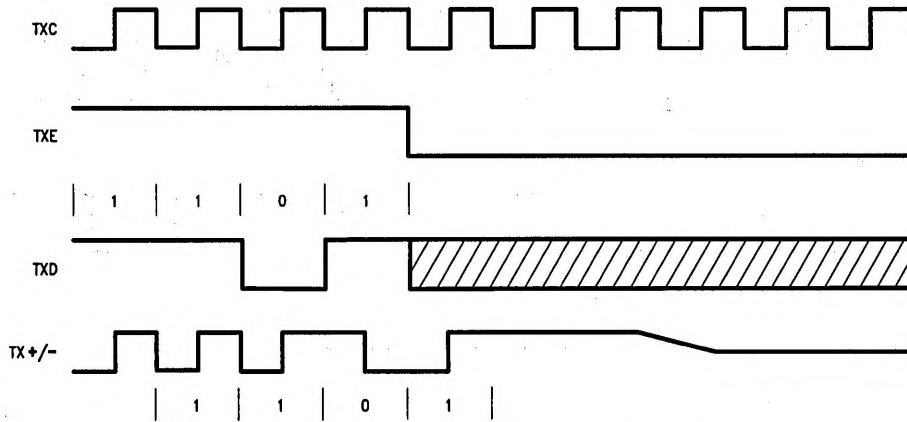

FIGURE 6. Transmit Timing - End of Transmission (last bit = 1)

TL/F/9357-8

9.0 Timing and Load Diagrams (Continued)

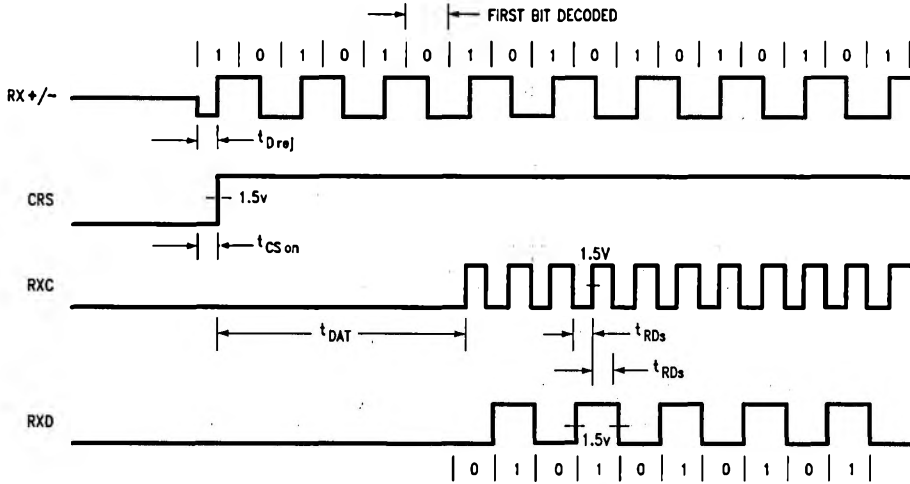

FIGURE 7. Receive Timing - Start of Packet

TL/F/9357-9

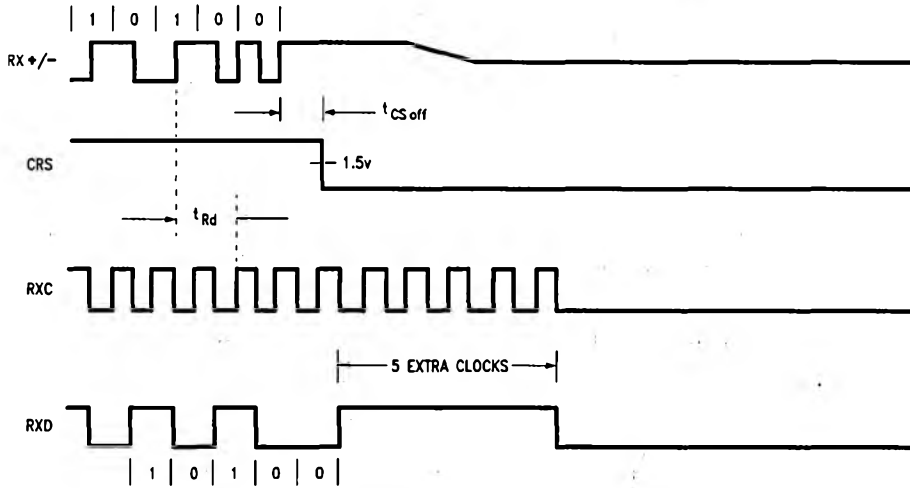

FIGURE 8. Receive Timing - End of Packet (last bit = 0)

TL/F/9357-10

9.0 Timing and Load Diagrams (Continued)

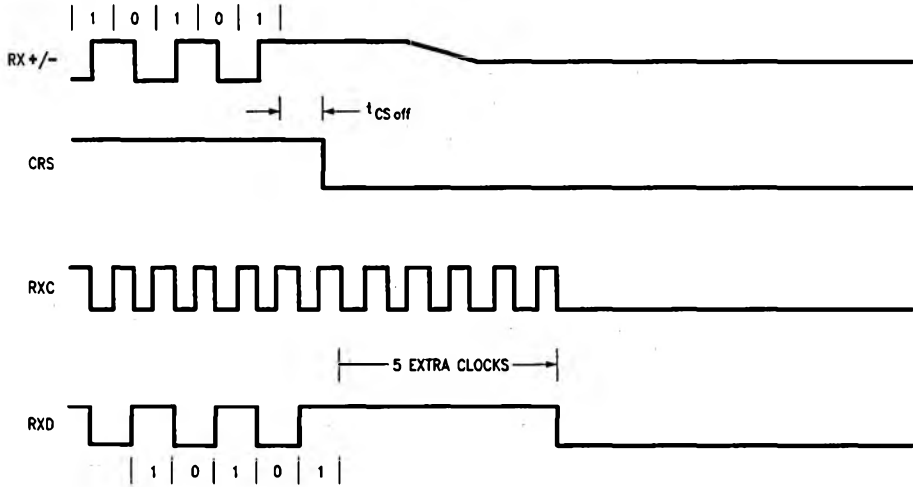

FIGURE 9. Receive Timing - End of Packet (last bit = 1)

TL/F/9357-11

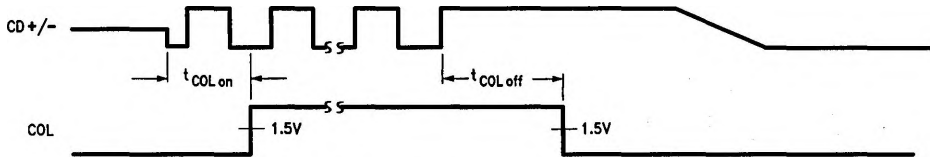

FIGURE 10. Collision Timing

TL/F/9357-12

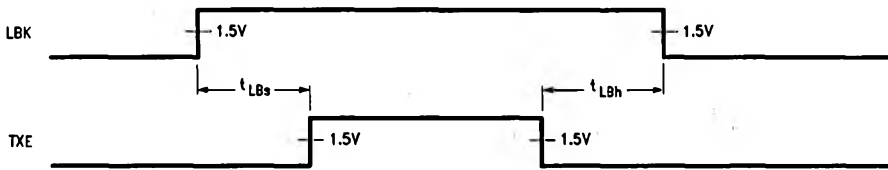
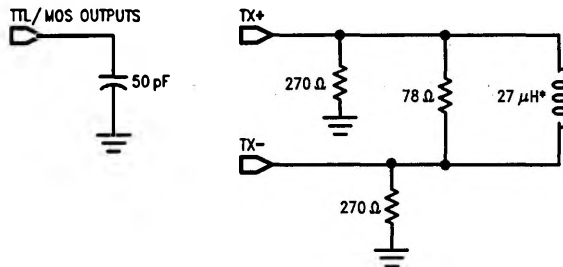

FIGURE 11. Loopback Timing

TL/F/9357-13



TL/F/9357-14

*27 μH transformer is used for testing purposes, 100 μH transformers (Valor, LT1101, or Pulse Engineering 64103) are recommended for application use.

FIGURE 12. Test Loads