



# TTL MSI

DM5442/DM7442

## DM5442/DM7442 (SN5442/SN7442) BCD to decimal decoder

### general description

The DM5442/DM7442 utilizes Series 54/74 compatible circuitry to decode a four-bit BCD number to one-of-ten decimal outputs. These ten decimal outputs are capable of driving 10 standard TTL loads each.

The decoding logic is designed such that when binary numbers between 10 and 15 are applied to the inputs, no outputs are enabled.

### logic and connection diagrams

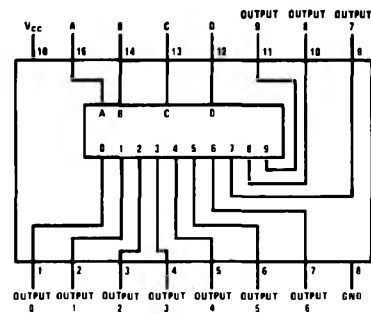
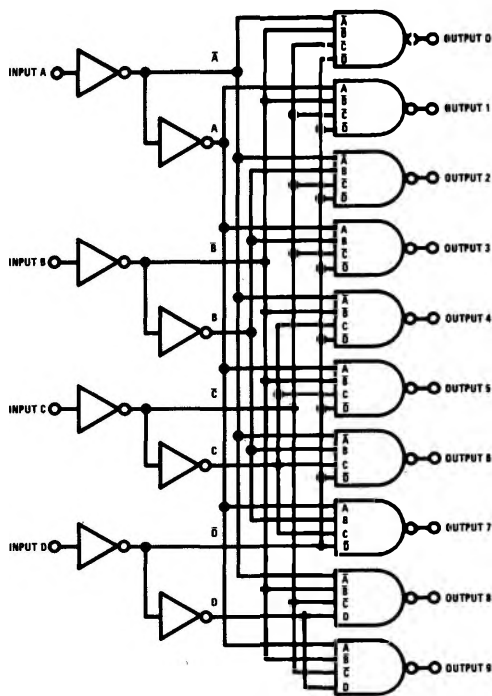

### logic table

INPUTS				OUTPUTS									
D	C	B	A	0	1	2	3	4	5	6	7	8	9
0	0	0	0	0	1	1	1	1	1	1	1	1	1
0	0	0	1	0	1	0	1	1	1	1	1	1	1
0	0	1	0	1	1	0	1	1	1	1	1	1	1
0	0	1	1	0	1	1	0	1	1	1	1	1	1
0	1	0	0	1	1	1	1	0	1	1	1	1	1
0	1	0	1	1	1	1	1	0	1	1	1	1	1
0	1	1	0	1	1	1	1	1	0	1	1	1	1
0	1	1	1	1	1	1	1	1	0	1	1	1	1
1	0	0	0	1	1	1	1	1	1	1	1	1	1
1	0	0	1	1	1	1	1	1	1	1	1	1	1
1	0	1	0	1	1	1	1	1	1	1	1	1	1
1	0	1	1	1	1	1	1	1	1	1	1	1	1
1	1	0	0	1	1	1	1	1	1	1	1	1	1
1	1	0	1	1	1	1	1	1	1	1	1	1	1
1	1	1	0	1	1	1	1	1	1	1	1	1	1
1	1	1	1	1	1	1	1	1	1	1	1	1	1

### typical application

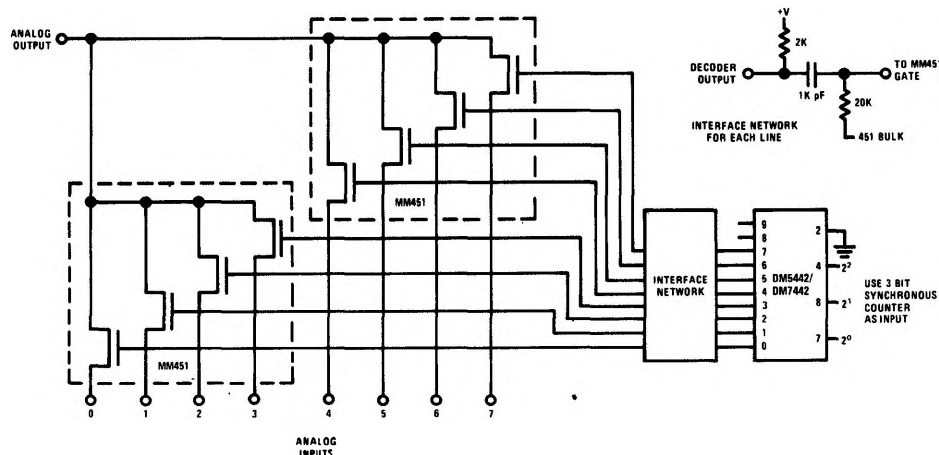

**absolute maximum ratings**

Supply Voltage	+7V
Input Voltage	+5.5V
Fan Out	10
Storage Temperature Range	-65°C to +150°C
Operating Temperature Range	
DM5442	-55°C to +125°C
DM7442	0°C to +70°C
Lead Temperature (Soldering, 10 sec)	300°C

**electrical characteristics** (Note 1)

PARAMETER	CONDITION	MIN	TYP	MAX	UNITS
Logical "1" Input Voltage	DM5442 $V_{CC} = 4.5V$	2.0			V
	DM7442 $V_{CC} = 4.75V$				
Logical "0" Input Voltage	DM5442 $V_{CC} = 4.5V$			0.8	V
	DM7442 $V_{CC} = 4.75V$				
Logical "1" Output Voltage	DM5442 $V_{CC} = 4.5V$	2.4			V
	DM7442 $V_{CC} = 4.75V$				
Logical "0" Output Voltage	DM5442 $V_{CC} = 4.5V$			0.4	V
	DM7442 $V_{CC} = 4.75V$				
Logical "1" Input Current	DM5442 $V_{CC} = 5.5V$			40	$\mu A$
	DM7442 $V_{CC} = 5.25V$				
Logical "1" Input Current	DM5442 $V_{CC} = 5.5V$			1	mA
	DM7442 $V_{CC} = 5.25V$				
Logical "0" Input Current	DM5442 $V_{CC} = 5.5V$		-1.0	-1.6	mA
	DM7442 $V_{CC} = 5.25V$				
Input Clamp Diode (All Inputs)	DM5442 $V_{CC} = 5.5V$		-1.0	-1.5	V
	DM7442 $V_{CC} = 5.25V$				
Output Short Circuit Current (Note 2)	DM5442 $V_{CC} = 5.5V$	-20	-32	-55	mA
	DM7442 $V_{CC} = 5.25V$	-18			
Power Supply Current	DM5442 $V_{CC} = 5.5V$		28	56	mA
	DM7442 $V_{CC} = 5.25V$				
Propagation Delay Time to a Logical "0" (2 Logic Levels)	$V_{CC} = 5.0V, T_A = 25^\circ C,$ $C_{OUT} = 50 pF, F.O. = 10$	10	23	30	ns
Propagation Delay Time to a Logical "1" (2 Logic Levels)	$V_{CC} = 5.0V, T_A = 25^\circ C,$ $C_{OUT} = 50 pF, F.O. = 10$	8	17	25	ns
Propagation Delay Time to a Logical "0" (3 Logic Levels)	$V_{CC} = 5.0V, T_A = 25^\circ C,$ $C_{OUT} = 50 pF, F.O. = 10$	12	24	35	ns
Propagation Delay Time to a Logical "1" (3 Logic Levels)	$V_{CC} = 5.0V, T_A = 25^\circ C,$ $C_{OUT} = 50 pF, F.O. = 10$	12	26	35	ns

**Note 1:** Min/max limits apply across the guaranteed operating temperature range -55°C to +125°C for DM5442 and 0°C to 70°C for the DM7442 unless otherwise specified. All typicals are given for  $V_{CC} = 5.0V$  and  $T_A = 25^\circ C$ .

**Note 2:** Only one output may be shorted at a time.

typical performance characteristics

Transition Time to Logical "1" ( $t_{pd1}$ ) (2 Logic Levels)

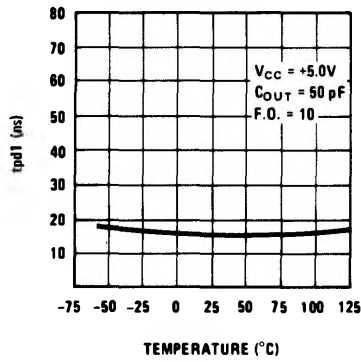

Transition Time to Logical "1" ( $t_{pd1}$ ) (3 Logic Levels)

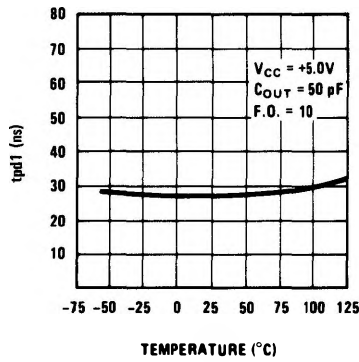

Transition Time to Logical "0" ( $t_{pd0}$ ) (2 Logic Levels)

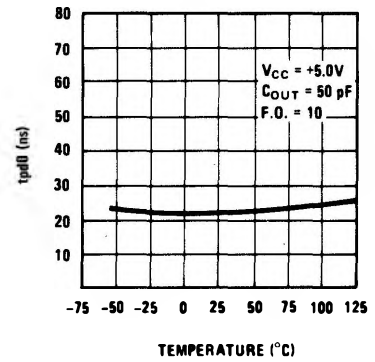

Transition Time to Logical "0" ( $t_{pd0}$ ) vs Temperature (3 Logic Levels)

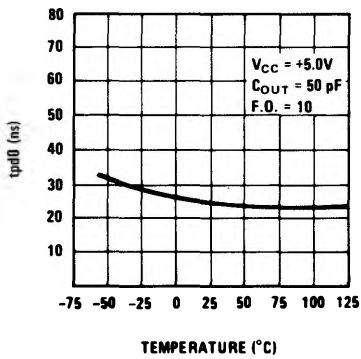

Input Threshold vs Temperature

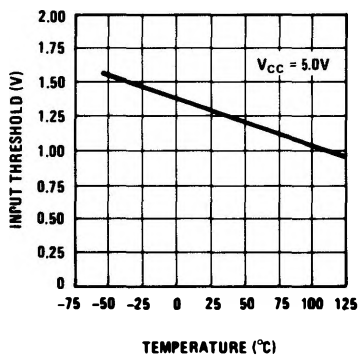

Logical "0" Output Voltage vs Sink Current

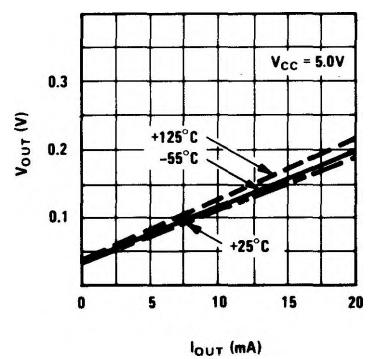

Logical "1" Output Voltage vs Source Current

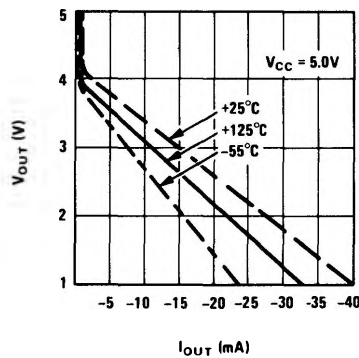

Input Clamp Diode Characteristics

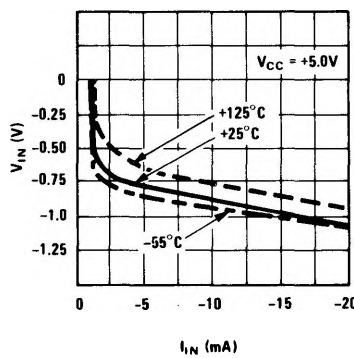

ac test circuit

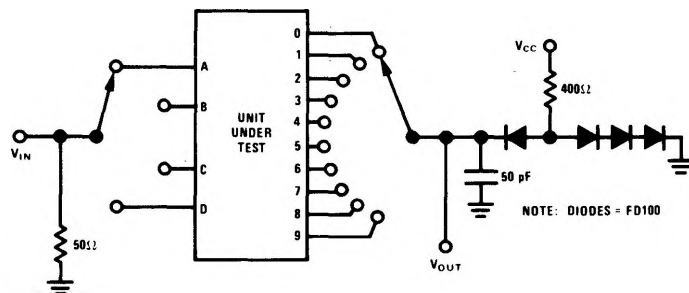

switching time waveforms

