

DBL 1009

PLL FM STEREO MULTIPLEX

Space merit by the package and wide supply voltage range.

FEATURES

- Excellent pilot lamp turning-on sensitivity :
 $V_{LAMP(ON)} = 9mVrms$ (Typ.)
- Suitable for LED driving :
 $I_{LAMP} = 20mA$ (Max.)
- Recommendable input voltage range :
 $V_{IN} = 200 \sim 700mVrms$
- Operating supply voltage range :
 $V_{CC} = 3.5 \sim 12V$
- Excellent channel separation through entire audio frequency range :
 $CH_{SEP} = 45dB$ (Typ.)
- Low distortion : THD = 0.08% (Typ.) at $V_{IN} = 200mVrms$ (stereo)
- VCO stop capability (The VCO is stopped when the Pin 7 is connected with the power supply line, and then the stereo indicator is turn off.)
- Easy adjustment (The monitored free running frequency of VCO is 38KHz at Pin 6.)

APPLICATIONS

- Automotive and portable radios.

MAXIMUM RATINGS (Ta=25°C)

Characteristic		Symbol	Rating	Unit
Supply Voltage		V_{CC}	12	V
Lamp Voltage		V_{LAMP}	16	V
Lamp Current	Continuation	I_{LAMP}	20	mA
	Peak		40	
Operating Temperature		T_{opr}	-30 ~ + 75	°C
Storage Temperature		T_{stg}	-55 ~ + 150	°C
Power Dissipation		P_D	500	mW

* The power dissipation is derated above Ta = 25°C in the proportion of 4mW/°C

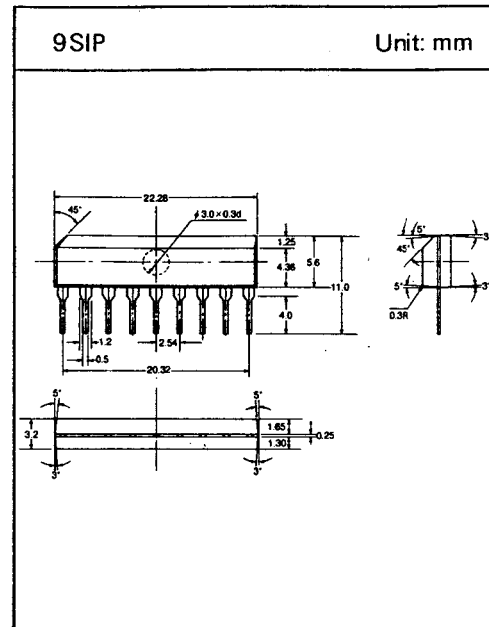

DBL 1009

□ ELECTRICAL AC CHARACTERISTICS

(Unless otherwise specified, $T_a = 25^\circ\text{C}$, $V_{CC} = 8\text{V}$, $f = 1\text{kHz}$)

Characteristic		Symbol	Test Condition	Min.	Typ.	Max.	Unit	
Supply Current		I_{CC}	at Lamp Off	—	11	18	mA	
Input Resistance		R_{IN}	—	—	33	—	k Ω	
Max. Composite Signal Input Voltage		$V_{IN(MAX)}$ (Stereo)	L + R = 90%, P = 10%, THD = 1%	—	900	—	mVrms	
Channel Separation		CH_{SEP}	L + R = 180mVrms, P = 20mVrms	36	45	—	dB	
Total Harmonic Distortion	Monaural	THD (Monaural)	$V_{IN} = 200\text{mVrms}$	—	0.08	0.3	%	
	Stereo	THD (Stereo)	L + R = 180mVrms, P = 20mVrms	—	0.08	—	%	
Voltage Gain		G_V	$V_{IN} = 200\text{mVrms}$	-2	0.5	+2	dB	
Channel Balance		CH_{BAL}	$V_{IN} = 200\text{mVrms}$	—	0	1.5	dB	
Lamp Sensitivity	ON	$V_{L(ON)}$	Pilot Input	—	10	15	mVrms	
	OFF	$V_{L(OFF)}$		2	6	—	mVrms	
Stereo Lamp Hysteresis		V_H	To Turn Off from Lamp Turn On	—	3	—	mVrms	
Capture Range		C.R.	P = 20mVrms	—	± 3	—	%	
Carrier Leak	19kHz	C.L.	L + R = 180mVrms, P = 20mVrms	—	34	—	dB	
	38kHz			—	42	—		
Signal to Noise Ratio		S/N	$V_{IN} = 180\text{mVrms}$, $f = 1\text{kHz}$ $R_g = 620\Omega$	—	74	—	dB	
Output Current(pin 8, pin 9)		I_{OUT}	$R_L = 3.3\text{k}\Omega$	$V_{CC} = 3.5\text{V}$	—	0.3	0.6	mA
				$V_{CC} = 8\text{V}$	—	1.2	1.8	
				$V_{CC} = 12\text{V}$	—	1.4	2.1	

□ ELECTRICAL DC CHARACTERISTICS ($V_{CC} = 8\text{V}$, Terminal Voltage at No Signal)

Terminal	Characteristic	Symbol	Rating	Unit
1.	(Input)	V_1	3.5	V
2.	(L.P.F 1)	V_2	6.6	V
3.	(V_{CC})	V_3	8	V
4.	(VCO)	V_4	7.1	V
5.	(GND)	V_5	0	V
6.	(ST.LAMP)	V_6	—	V
7.	(L.P.F 2)	V_7	7.4	V
8.	(L-CH Output)	V_8	4	V
9.	(R-CH Output)	V_9	4	V

DBL 1009

□ BLOCK DIAGRAM

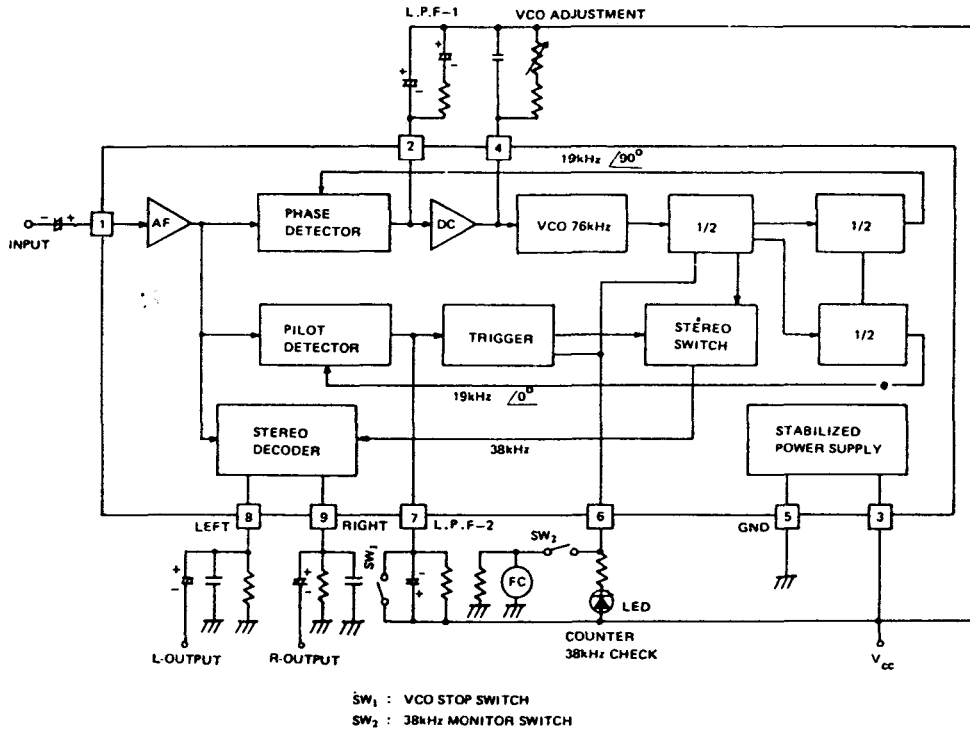

□ TEST CIRCUIT

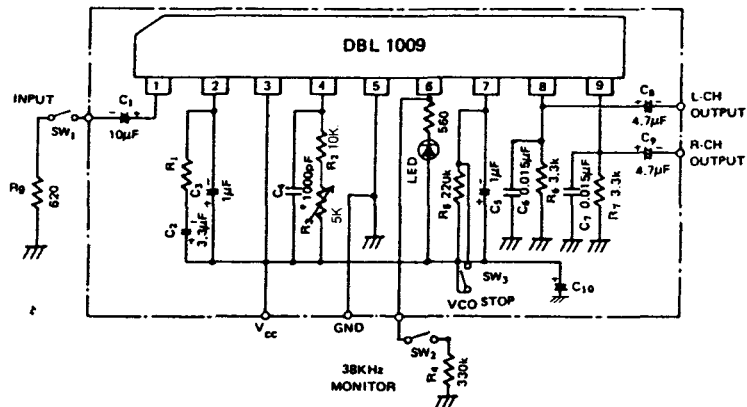

DBL 1009

TYPICAL PERFORMANCE CHARACTERISTICS

