

## 8-BIT D/A CONVERTERS

- **RELATIVE ACCURACY:**  $\pm 0.19\%$  ERROR MAXIMUM (DAC0808)
- **FULL SCALE CURRENT MATCH:**  $\pm 1$  LSB TYP
- **7 AND 6-BIT ACCURACY AVAILABLE** (DAC0807, DAC0806)
- **FAST SETTING TIME:** 150 ns TYP
- **NONINVERTING DIGITAL INPUTS ARE TTL AND CMOS COMPATIBLE**
- **HIGH SPEED MULTIPLYING INPUT SLEW RATE:** 8 mA/ $\mu$ s
- **POWER SUPPLY VOLTAGE RANGE:**  $\pm 4.5$ V to  $\pm 18$ V
- **LOW POWER CONSUMPTION:** 33 mW @  $\pm 5$ V

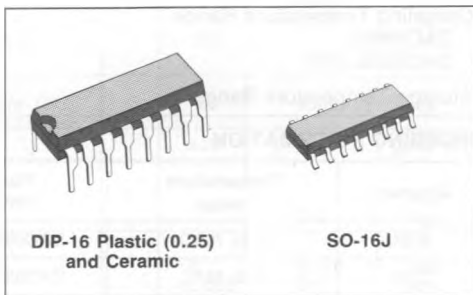

### PIN CONNECTION

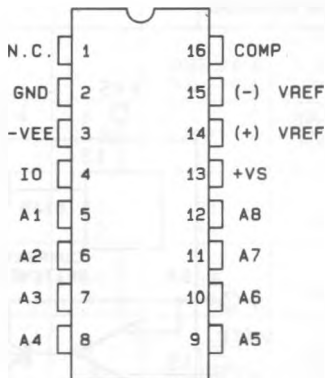

DAC0808-13

### DESCRIPTION

The DAC0808 series is an 8-bit monolithic digital-to-analog converter (DAC) featuring a full scale output current settling time of 150 ns while dissipating only 33 mW with  $\pm 5$ V supplies. No reference current ( $I_{REF}$ ) trimming is required for most applications since the full scale output current is typically  $\pm 1$  LSB of  $255 I_{REF}/256$ . Relative accuracies of better than 0.19% assure 8-bit monotonicity and linearity while zero level output current of less than 4  $\mu$ A provides 8-bit zero accuracy for  $I_{REF} \geq 2$  mA. The power supply currents of the DAC0808 series are independent of bit codes, and exhibits essentially constant device characteristics over the entire supply voltage range.

The DAC0808 will interface directly with popular TTL or CMOS logic levels, and is a direct replacement for the MC1508/MC1408.



## ELECTRICAL CHARACTERISTICS

$V_S = 5V$ ,  $V_{EE} = -15V$ ,  $V_{REF}/R_{14} = 2 \text{ mA}$ ,  $T_A = T_{MIN}$  to  $T_{MAX}$  and all digital inputs at high logic level unless otherwise noted.)

Parameter		Test Conditions	Min.	Typ.	Max.	Unit
$E_r$	Relative Accuracy (Error Relative to Full Scale $I_O$ )	(Figure 10)				%
	DAC0808L				$\pm 0.19$	%
	DAC0807LC/D1 (Note 1)				$\pm 0.39$	%
	DAC0806LC/D1 (Note 1)				$\pm 0.78$	%
	Settling Time to Within 1/2 LSB (Includes $t_{PLH}$ )	$T_A = 25^\circ\text{C}$ (Note 2) (Figure 11)		150		ns
$t_{PLH}$ $t_{PHL}$	Propagation Delay Time	$T_A = 25^\circ\text{C}$ (Figure 11)		30	100	ns
$TCI_O$	Output Full Scale Current Drift			$\pm 20$		ppm/ $^\circ\text{C}$
$V_{SB}$ $V_{BH}$ $V_{BL}$	Digital Input Logic Levels High Level, Logic "1" Low Level, Logic "0"	(Figure 9)	2		0.8	$V_{DC}$ $V_{DC}$
$I_{SB}$	Digital Input Current High Level	(Figure 9) $V_{IH} = 5V$ $V_{IL} = 0.8V$		0	0.040	mA
	Low Level			-0.003	-0.8	mA
$I_{15}$	Reference Input Bias Current	(Figure 3)		-1	-3	$\mu\text{A}$
	Output Current Range	(Figure 9) $V_{EE} = -5V$ $V_{EE} = -15V$ , $T_A = 25^\circ\text{C}$	0 0	2.0 2.0	2.1 4.2	mA mA
$I_O$	Output Current	$V_{REF} = 2.000V$ . $R_{14} = 1000\Omega$ (Figure 9)	1.9	1.99	2.1	mA
	Output Current, All Bits Low	(Figure 9)		0	4	$\mu\text{A}$
	Output Voltage Compliance $V_{EE} = -5V$ $V_{EE}$ Below $-10V$	$E_r \leq 0.19\%$ , $T_A = 25^\circ\text{C}$			-0.55, +0.4 -5.0, +0.4	V V
$SRI_{REF}$	Reference Current Slew Rate Output Current Power Supply Sensitivity	(Figure 14) $-5V \leq V_{EE} \leq -16.5V$	4	8 0.05	2.7	mA/ $\mu\text{s}$ $\mu\text{A}/V$
$I_S$ $I_{EE}$	Power Supply Current (All Bits Low)	(Figure 9)		2.3 -4.3	22 -13	mA
$V_S$ $V_{EE}$	Power Supply Voltage Range	$T_A = 25^\circ\text{C}$ (Figure 9)	4.5 -4.5	5.0 -15	5.5 -16.5	V
	Power Dissipation All Bits Low	$V_S = 5V$ , $V_{EE} = -5V$ $V_S = 5V$ , $V_{EE} = -15V$		33 106	170 305	mW mW
	All Bits High	$V_S = 15V$ , $V_{EE} = -5V$ $V_S = 15V$ , $V_{EE} = -15V$		90 160		mW mW

Note 1: All current switches are tested to guarantee at least 50% of rated current.

Note 2: All bits switched.

Note 3: Range control is not required.

Fig. 1 - Supply Current vs Temperature

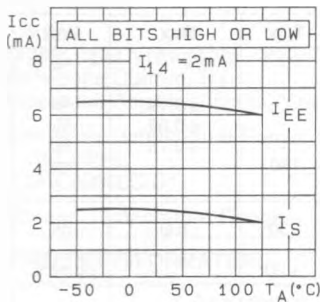

Fig. 2 - Supply Current vs Supply Voltage ( $V_{EE}$ )

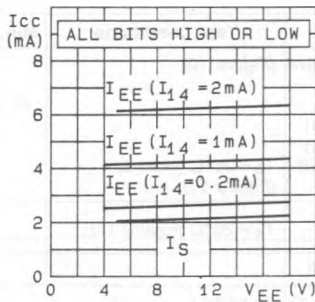

Fig. 3 - Supply Current vs Supply Voltage ( $V_S$ )

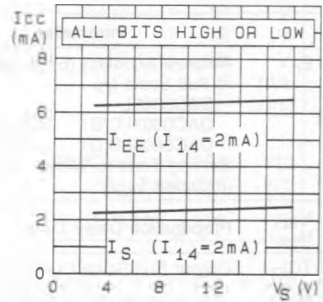

Fig. 4 - Logic Input Current vs Input Voltage

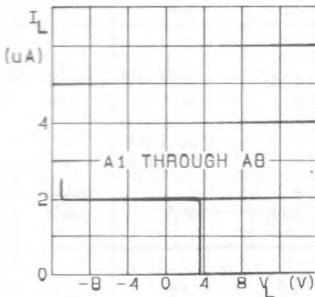

Fig. 5 - Bit Transfer Characteristics

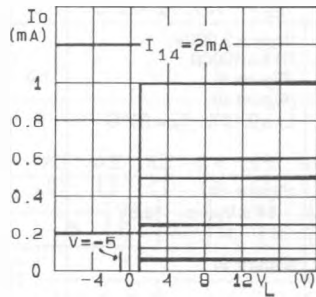

Fig. 6 - Output Voltage Compliance

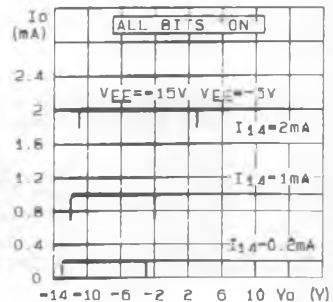

Fig. 7 - Output Voltage Compliance vs Temperature

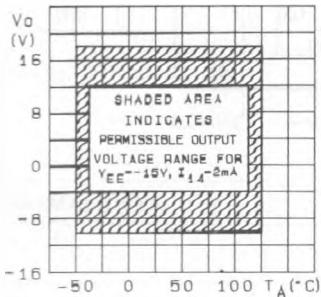
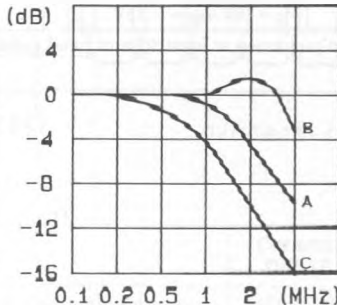

Fig. 8 - Frequency response



Unless otherwise specified:  $R_{14} = R_{15} = 1\text{ k}\Omega$ ,  $C = 15\text{ pF}$ , pin 16 to  $V_{EE}$ ;  $R_L = 500\Omega$ , pin 4 to ground.

**Curve A:** Large Signal Bandwidth Method of Figure 7,  $V_{REF} = 2\text{ Vp-p}$  offset 1 V above ground

**Curve B:** Small Signal Bandwidth Method of Figure 7,  $R_L = 250\Omega$ ,  $V_{REF} = 50\text{ mVp-p}$  offset 200 mV above ground.

**Curve C:** Large and Small Signal Bandwidth Method of Figure 9 (no op amp,  $R_L = 500\Omega$ ),  $R_S = 500\Omega$ ,  $V_{REF} = 2\text{V}$ ,  $V_S = 100\text{ mVp-p}$  centered at 0V.

Test Circuits

FIGURE 9. Notation Definitions

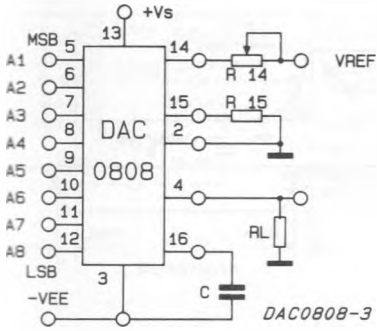

The resistor tied to pin 15 is to temperature compensate the bias current and may not be necessary for all applications.

$$I_O = K \left( \frac{A_1}{2} + \frac{A_2}{4} + \frac{A_3}{8} + \frac{A_4}{16} + \frac{A_5}{32} + \frac{A_6}{64} + \frac{A_7}{128} + \frac{A_8}{256} \right)$$

where  $K \equiv \frac{V_{REF}}{R_{14}}$

and  $A_N = "1"$  if  $A_N$  is at high level  
 $A_N = "0"$  if  $A_N$  is at low level

FIGURE 10. Relative Accuracy

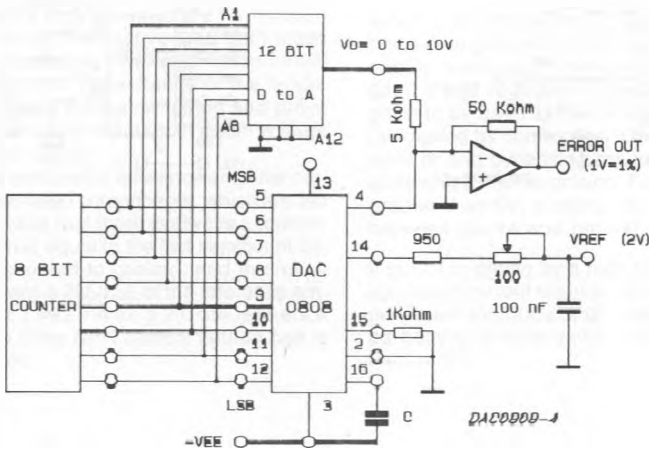

FIGURE 11. Transient Response and Settling Time

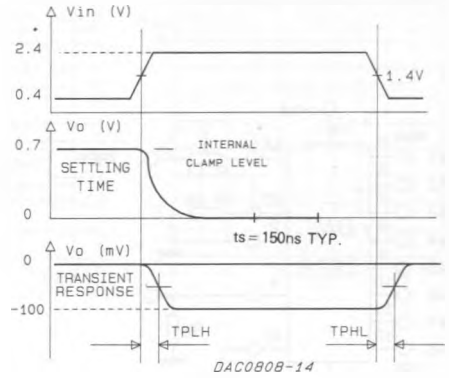
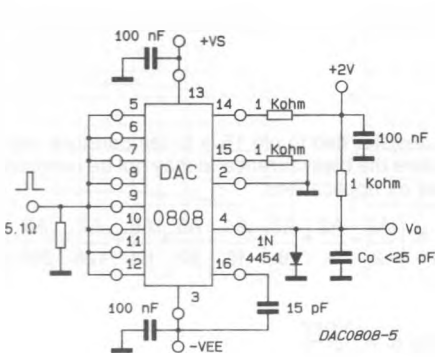

FIGURE 12. Positive VREF

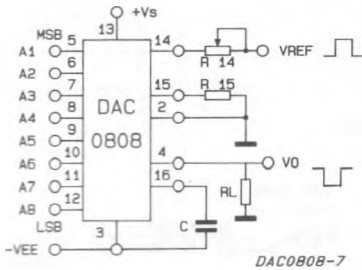

FIGURE 13. Negative VREF

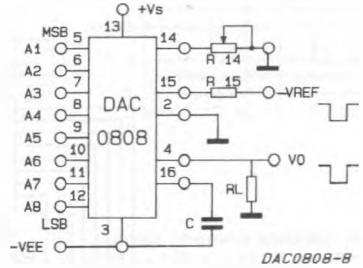
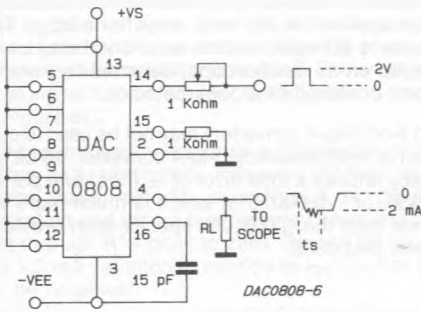

FIGURE 14. Reference Current Slew Rate Measurement



## APPLICATION INFORMATION

### CIRCUIT DESCRIPTION

The DAC0808 consists of a reference current amplifier, an R-2R ladder, and eight high-speed current switches. For many applications, only a reference resistor and reference voltage need be added.

The switches are noninverting in operation, therefore a high state on the input turns on the specified output current component. The switch uses current steering for high speed, and a termination amplifier consisting of an active load gain stage with unity gain feedback. The termination amplifier holds the parasitic capacitance of the ladder at a constant voltage during switching and provides a low impedance termination of equal voltage for all legs of the ladder.

The R-2R ladder divides the reference amplifier current into binarily-related components, which are fed to the switches. Nota that there is always a remainder current which is equal to the last significant bit. This current is shunted to ground, and the maximum output current is 255/256 of the reference amplifier current, or 1.992 mA for a 2.0 mA reference amplifier current if the NPN current source pair is perfectly matched.

### REFERENCE AMPLIFIER DRIVE AND COMPENSATION

The reference amplifier provides a voltage at pin 14 for converting the reference voltage to a current, and a turn-around circuit or current mirror for feeding the ladder. The reference amplifier input current,  $I_{14}$ , must always flow into pin 14, regardless of the set-up method or reference voltage polarity.

Connections for a positive voltage are shown in *Figure 12*. The reference voltage source supplies the full current  $I_{14}$ . For bipolar reference signals, as in the multiplying mode,  $R_{15}$  can be tied to a negative voltage corresponding to the minimum input level. It is possible to eliminate  $R_{15}$  with only a small sacrifice in accuracy and temperature drift.

The compensation capacitor value must be increased with increases in  $R_{14}$  to maintain proper phase margin; for  $R_{14}$  values of 1, 2.5 and 5 k $\Omega$ , minimum capacitor values are 15, 37 and 75 pF. The capacitor may be tied to either  $V_{EE}$  or ground, but using  $V_{EE}$  increases negative supply rejection.

A negative reference voltage may be used if  $R_{14}$  is grounded and the reference voltage is applied to  $R_{15}$  as shown in *Figure 13*. A high input impedance is the main advantage of this method. Compensation involves a capacitor to  $V_{EE}$  on pin 16, using the values of the previous paragraph. The negative reference voltage must be at least 3V above the  $V_{EE}$  supply. Bipolar input signals may be handled by connecting  $R_{14}$  to a positive reference voltage equal to the peak positive input level at pin 15.

When a DC reference voltage is used, capacitive by pass to ground is recommended. The 5V logic supply is not recommended as a reference voltage. If a well regulated 5V supply which drives logic is to be used as the reference,  $R_{14}$  should be decoupled by connecting it to 5V through another resistor and bypassing the junction of the 2 resistors with 0.1  $\mu$ F to ground. For reference voltages greater than 5V, a clamp diode is recommended between pin 14 and ground.

If pin 14 is driven by a high impedance such as a transistor current source, none of the above compensation methods apply and the amplifier must be heavily compensated, decreasing the overall bandwidth.

## OUTPUT VOLTAGE RANGE

The voltage on pin 4 is restricted to a range of  $-0.6$  to  $0.5V$  when  $V_{EE} = -5V$  due to the current switching methods employed in the DAC0808.

The negative output voltage compliance of the DAC0808 is extended to  $-5V$  where the negative supply voltage is more negative than  $-10V$ . Using a full-scale current of  $1.992\text{ mA}$  and load resistor of  $2.5\text{ k}\Omega$  between pin 4 and ground will yield a voltage output of 256 levels between 0 and  $-4.980V$ . Floating pin 1 does not affect the converter speed or power dissipation. However, the value of the load resistor determines the switching time due to increased voltage swing. Values of  $R_L$  up to  $500\Omega$  do not significantly affect performance, but a  $2.5\text{ k}\Omega$  load increases worst-case setting time to  $1.2\text{ }\mu\text{s}$  (when all bits are switched ON). Refer to the subsequent text section on Settling Time for more details output loading.

## OUTPUT CURRENT RANGE

The output current maximum rating of  $4.2\text{ mA}$  may be used only for negative supply voltages more negative than  $-7V$ , due to the increased voltage drop across the resistors in the reference current amplifier.

## ACCURACY

Absolute accuracy is the measure of each output current level with respect to its intended value, and is dependent upon relative accuracy and full-scale current drift. Relative accuracy is the measure of each output current level as a fraction of the full-scale current. The relative accuracy of the DAC0808 is essentially constant with temperature due to the excellent temperature tracking of the monolithic resistor ladder. The reference current may drift with temperature, causing a change in the absolute accuracy of output current. However, the DAC0808 has a very low full-scale current drift with temperature.

The DAC0808 series is guaranteed accurate to within  $\pm 1/2\text{ LSB}$  at a full-scale output current of  $1.992\text{ mA}$ . This corresponds to a reference amplifier output current drive to the ladder network of  $2\text{ mA}$ , with the loss of  $1\text{ LSB}$  ( $8\text{ }\mu\text{A}$ ) which is the ladder remainder shunted to ground. The input current to pin 14 has a guaranteed value of between  $1.9$  and  $2.1\text{ mA}$ , allowing some mis-match in the NPN current source pair. The accuracy test circuit is shown in Figure 10. The 12-bit converter is calibrated for a full-scale output current of  $1.992\text{ mA}$ . This is an optional step since the DAC0808 accuracy is essentially the same between  $1.5$  and  $2.5\text{ mA}$ .

Then the DAC0808 circuits' full-scale current is trimmed to the same value with R14 so that a zero value appears at the error amplifier output. The counter is activated and the error band may be displayed on an oscilloscope, detected by comparators, or stored in a peak detector.

Two 8-bit D-to-A converters may not be used to construct a 16-bit accuracy D-to-A converter. 16-bit accuracy implies a total error of  $\pm 1/2$  of one part in 65,536, or  $\pm 0.00076\%$ , which is much more accurate than the  $\pm 0.019\%$  specification provided by the DAC0808.

## MULTIPLYING ACCURACY

The DAC0808 may be used in the multiplying mode with 8-bit accuracy when the reference current is varied over a range of 256:1. If the reference current in the multiplying mode ranges from  $16\text{ }\mu\text{A}$  to  $4\text{ mA}$ , the additional error contributions are less than  $1.6\text{ }\mu\text{A}$ . This is well within 8-bit accuracy when referred to full-scale.

A monotonic converter is one which supplies an increase in current for each increment in the binary word. Typically, the DAC0808 is monotonic for all values of reference current above  $0.5\text{ mA}$ . The recommended range for operation with a DC reference current is  $0.5$  to  $4\text{ mA}$ .

## SETTLING TIME

The "worst case" switching condition occurs when all bits are switched "on", which corresponds to a low-high transition for all bits. This time is typically  $150\text{ ns}$  for settling to within  $\pm 1/2\text{ LSB}$  for 8-bit accuracy and  $100\text{ ns}$  to  $1/2\text{ LSB}$  for 7 and 6-bit accuracy. The turn off is typically under  $100\text{ ns}$ . These timers apply when  $R_L \leq 500\text{ ohms}$  and  $C_0 \leq 25\text{ pF}$ .

The test circuit of Figure 11 requires a smaller voltage swing for the current switches due to internal voltage clamping in the DAC0808. A  $10\text{-k}\Omega$  load resistor from pin 4 to ground gives a typical settling time of  $200\text{ ns}$ .

Thus, it is voltage swing and not the output RC time constant that determines setting time for most applications.

Extra care must be taken in board layout since this is usually the dominant factor in satisfactory test results when measuring settling time.

Short leads,  $100\text{ }\mu\text{F}$  supply bypassing for low frequencies, and minimum scope lead length are all mandatory.



### PROGRAMMABLE GAIN AMPLIFIER OR DIGITAL ATTENUATOR

When used in the multiplying mode can be applied as a digital attenuator. See Figure 15. One advantage of this technique is that if  $R_S = 50$  ohms, no compensation capacitor is needed. The small and large signal band are now identical and are shown in Figure 8C.

The best frequency response is obtained by not allowing  $I_{14}$  to reach zero. However, the high impedance node, pin 16, is clamped to prevent saturation and insure fast recovery when the current through  $R_{14}$  goes to zero.  $R_S$  can be set for a  $\pm 1.0$  mA variation in relation to  $I_{14}$ .  $I_{14}$  can never be negative.

The output current is always unipolar. The quiescent dc output current level changes with the digital word which makes accoupling necessary.

### CURRENT TO VOLTAGE CONVERSION

Voltage output of a larger magnitude are obtainable with the circuit of fig. 16 which uses an external operational amplifier as a current to voltage converter. This configuration automatically keeps the output of the DAC0808 ground potential and the operational amplifier can generate a positive voltage limited only by its positive supply voltage. Frequency response and setting time are primarily determined by the characteristics of the operational amplifier. In addition, the operational amplifier must be compensated for unity gain, and in some cases over compensation may be desirable. Note that this configuration results in a positive output voltage only, the magnitude of which is dependent on the digital input. The LM301 can be used in a feedforward mode resulting in a full scale setting time on the order of  $2.0 \mu s$ .

### COMBINED OUTPUT AMPLIFIER AND VOLTAGE REFERENCE

For many of its applications the DAC0808 requires a reference voltage and an operational amplifier. Normally the operational amplifier is used as a current to voltage converter and its output need only go positive. With the popular LM723 voltage regulator both of these functions are provided in a single package with the added bonus of up to 150 mA output current. See Figure 17. The reference

voltage is developed with respect to the negative voltage and appears as a common-mode signal to the reference amplifier in the D-to-A converter. This allows use of its amplifier as a classic current-to-voltage converter with the non-inverting input grounded.

Since  $\pm 15V$  and  $+5.0V$  are normally available in a combination digital-to-analog system, only the  $-5.0V$  need be developed. A resistor divider is sufficiently accurate since the allowable range on pin 5 is from  $-2.0$  to  $-8.0$  volts. The  $5.0$  kilohm pulldown resistor on the amplifier output is necessary for fast negative transitions.

Full scale output may be increasing  $R_O$  and raising the  $+15V$  supply voltage to  $35V$  maximum. The resistor divider should be altered to comply with the maximum limit of 40 volts across the LM723  $C_O$  may be decreased to maintain the same  $R_O \cdot C_O$  product if maximum speed is desired.

### PROGRAMMABLE POWER SUPPLY

The circuit of figure 17 can be used as a digitally programmed power supply by the addition of thumb-wheel switches and a BCD-to-binary converter. The output voltage can be scaled in several ways, including 0 to  $+25.5$  volts in  $0.1$  -volt increments,  $\pm 10$  mV.

### PANEL METER READOUT

The DAC0808 can be used to read out the status of BCD or binary registers or counters a digital control system. The current output can be used to drive directly an analog panel meter. External meter shunts may be necessary if a meter of less than 20 mA full scale is used. Full scale calibration can be done by adjusting  $R_{14}$  or  $V_{ref}$  (see fig. 18).

### CHARACTER GENERATOR

In a character generation system fig. 19 one DAC0808 circuit uses a fixed reference voltage and its digital input defines the starting point for a stroke. The second converter circuit has a ramp input for the reference and its digital input defines the slope of the stroke. Note that this approach does not result in a 16-bit D-to-A converter (see Accuracy Section).

**TWO-DIGIT BCD CONVERSION**

Two 8-bit, D-to-A converters can be used to build a two digit BCD D-to-A or A-to-D converter (fig. 21). If both outputs feed the virtual ground of an operational amplifier, 10:1 current scaling can be achieved with a resistive current divider. If current output is desired, the units may be operated at full scale current levels of 4.0 mA and 0.4 mA with the outputs connected to sum the currents. The error of the D-to-A converter handling the least significant bits will be scaled down by a factor of ten and thus an DAC0806 may be used for the least significant word.

FIGURE 16.

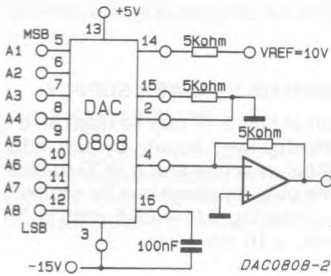

FIGURE 17. Combined output amplifier and voltage reference circuit

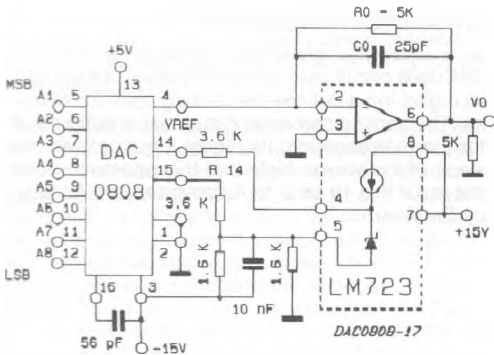
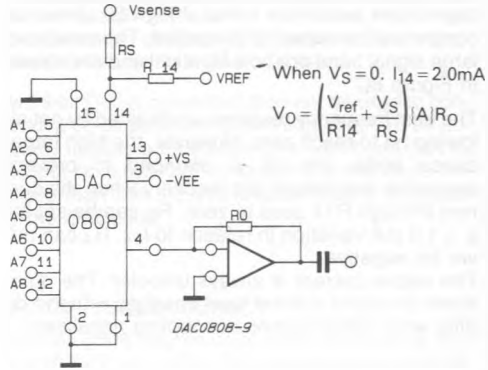
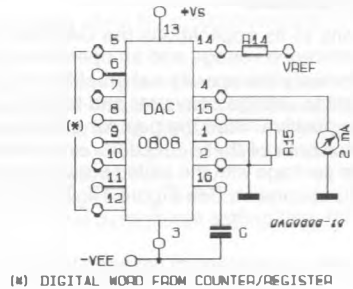

FIGURE 15. Programmable Gain Amplifier or Digital Attenuator Circuit



$$V_0 = 10V \left( \frac{A_1}{2} + \frac{A_2}{4} + \dots + \frac{A_8}{256} \right)$$

FIGURE 18. Panel meter readout circuit



(M) DIGITAL WORD FROM COUNTER/REGISTER

FIGURE 19. Digital summing and character generation

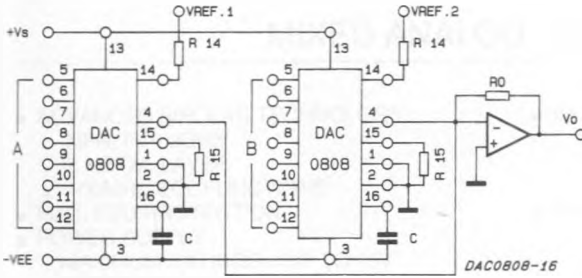

$$V_O = (I_{O1} + I_{O2}) R_O$$

$$V_O = \left[ \frac{V_{ref1}}{R14_1} |A| + \frac{V_{ref2}}{R14_2} |B| \right] R_O$$

FIGURE 20. Analog product of two digital words (High Speed Operation)

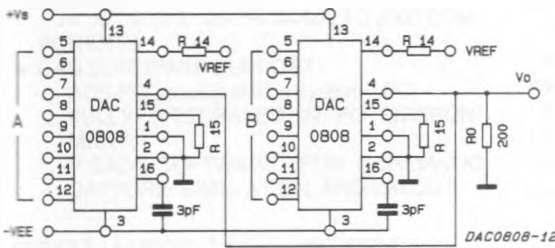

$$V_O = -I_{O1} R_O = \frac{V_{ref}}{R14_1} |A| R_O$$

$$I_{O2} = \frac{|B| |V_O|}{R14_2} = \frac{|B|}{R14_2} \left[ R_O \left( \frac{V_{ref}}{R14_1} \right) |A| \right]$$

Since  $R_O = R14_2$  and  $K = \frac{V_{ref}}{R14_1}$

$$I_{O2} = K |A| |B| \quad K \text{ can be an analog variable}$$

FIGURE 21. Two-digit BCD conversion

